

The A3-TFK™

The 3-rail, no-baste GraceFrame™ that Tilts, Folds—and you build it yourself

Materials Needed:

HARDWARE:

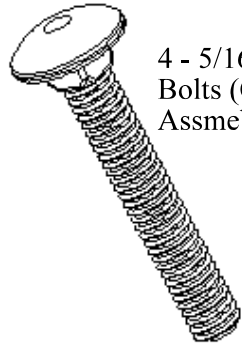

4 - 5/16" x 2" Carriage Bolts (Connecting Pole Assembly to Frame)

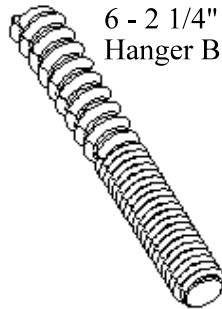

6 - 2 1/4" or 2 1/2" x 5/16" Hanger Bolts (Ends of Rails)



6 - 1/4" Smaller Flat Washers (3/4" outside diameter)

6 - 5/16" Nylock Nuts



6 - Standard Door Hinges (Tip: Grind the pins on the two that install on the brace-- Step 18)

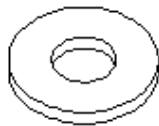
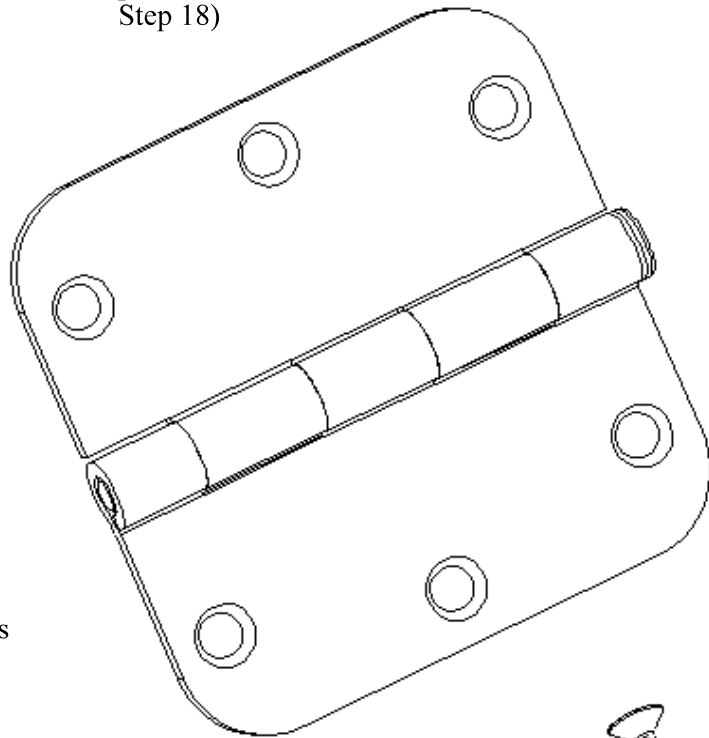

4 - 5/16" Larger Flat Washers (7/8" outside diameter)

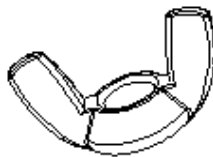

4 - 5/16" Wing Nuts

3 - 1/4"-20 TPI threaded wood inserts



(Either Knock-in --OR-- Thread-in style)

36 - 5/8" #8 Wood Screws (with tapered head for hinges)



3 - 1/4"-20 TPI x 1 1/2" Hex Head Cap Screw



16 - 1 1/4" Grabber Screws for Basic Frame --OR-- 8 - #0 Biscuits for Wood Jointer Frame.

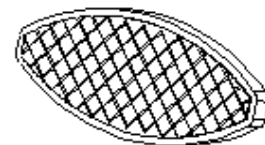

Materials Needed (con't):

LUMBER: We suggest using 1 x 4 pine or Douglas Fir. However, if you have a planer and a table saw any wood may be used. Review that pattern before purchase wood to make sure you get wood that is wide and long enough for the parts needed. If using dimensioned wood (1x4) you will need approximately six 8-ft. lengths. If using hardwood, you will need approximately 20 board feet (based on a 96" width frame—exact board feet and maximum length needed depends on length of brace). Choose the straightest material available by looking down the length of the wood. (NOTE: 1x4 wood actually measures 3/4" x 3 1/2")

RAILS: You may select stair railing for rails and simply cut them to length. For material less likely to warp, you may select additional 1x4 wood ripped in half, and glue them together (allow at least 1 hour dry time). You may also use 2x4 ripped in half for rails.

NOTE: For your added convenience, the complete packet of hardware is available at the Grace Company. To order, you can go online to www.graceframe.com.

Tools Needed (remember to always use safety glasses; consult the manuals of all machinery you use):

BASIC FRAME (approx. assembly time 4-6 hours:)

Saw—Hand, Power (Suggested) or Table (Preferred)
Drill—Hand, Power (Suggested) or Stationary (Preferred)
Drill Bits: 5/16" and 3/8"
Phillips Screw Driver
Pliers
Wood Glue

WOOD JOINTER FRAME (Advanced) (approx. assembly time 5-8):

Plate Jointer
All the above mentioned Tools

Stain/Finish Tip:

You may choose to use your frame finished or unfinished. If you choose to stain or finish the wood, it is best to do so after cutting and sanding but before assembling. Danish oil or Tung oil are good sealing agents that don't come off on fabric when given enough time to dry.

A3-TFK™ Assembly Instructions

Step 1: Determine Style of Frame

Determine which style of frame to build (Basic or Wood Jointer version). The pattern shows dotted or dashed lines for Wood Jointer/Biscuit cuts.

Step 2: Cut Out the Pattern

Cut out the patterns provided and either tape them to the 1x4's using double-sided tape, or trace them onto the wood and mark the center of the drill points.

Step 3: Cut Parts

Carefully cut all the parts except for the brace. This will be cut once the frame is assembled.

Step 4: Making and Sizing the Rails

Choose the size of quilt that your frame will accommodate and cut rails to the corresponding length. If you have chosen to use stair railing you only need to cut them to length. If you have chosen to glue two pieces of wood together, you can use a 1x4 ripped in half. This method reduces the chance of the rail warping. A 2x4 ripped in half is another source for a square rail.

Step 5: Cut Rail Tenons

Cut the tenons on the rails. Trace the tenon pattern (See diagrams on Pattern) onto the end of the rail. Make a 3/4" deep cut at each traced line. Then make a perpendicular cut to remove the unneeded pieces of wood leaving only the tenon.

Step 6: Drill Through-Holes

Drill all the through holes in the frame parts.

Step 7: Drill Wood Insert Holes

Drill the 1/2" deep holes in the frame parts. **Note:** To ensure you are drilling the correct depth, measure 1/2" from the tip of the drill bit and wrap a piece of tape around the bit. Only drill until the tapeline meets the surface of the wood.

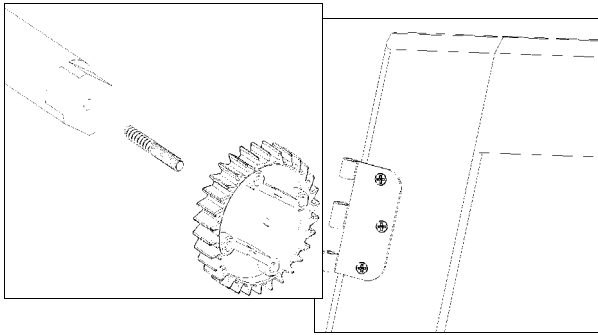

the hanger bolts in the hole).

Step 8: Drill Rail Holes

Drill the ends of the rails. The holes should be at least 1 1/2" deep. **Note:** Rotating the rail as you drill can help you keep the bit straight as it goes into the wood. The straighter the hanger bolts the better the rails roll once mounted on the frame. Put a few drops of glue in the hole and install with pliers (twist them in until all bigger threads are in

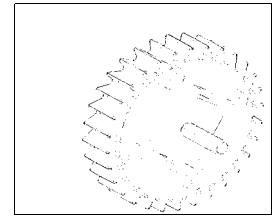

Step 9: Cog Wheels to Rails

Line up the rails as if you were at the front of the frame (wheels are on the right end of rail). Slide on the cog wheels so that the rail closest to you has the cog wheel teeth going away from you. The back two rails will have the teeth going toward you.

Step 10: Cog Stop Inserts and Stops

Screw in (or knock in) the cog stop inserts into the three 1/2" holes drilled into the Right Rail Mount End.

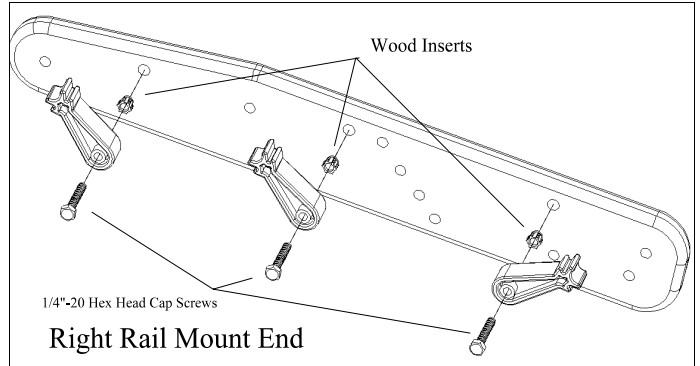

Step

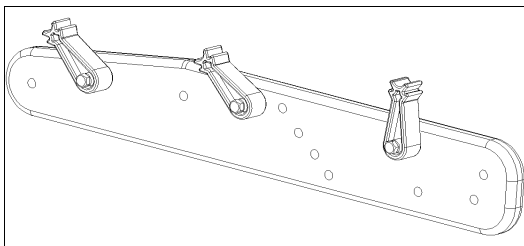

Basic Frame: Line up the frame legs, Top Sections, and Bottom Sections and screw them together. **Note:** We suggest you pre-drill and counter sink the holes for the grabber screws. *Wood Jointer Frame:* Make biscuit cuts and insert biscuits and parts together.

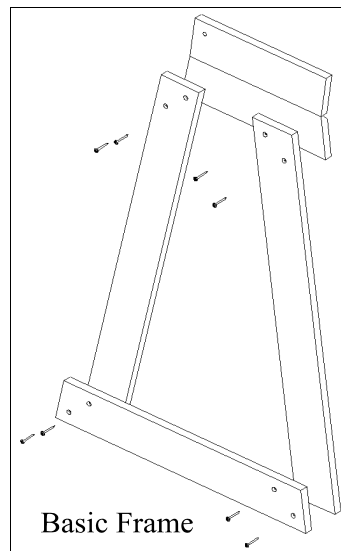

11: Joining frame parts

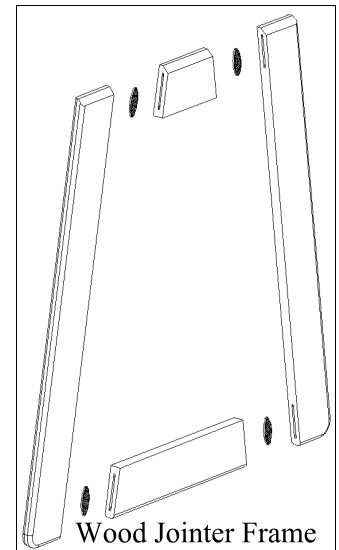

Step 12: Legs to Sides

Line up and connect the Pivot Boards to the Top Sections. Pre-drill and countersink the wood screws on hinges (see below).

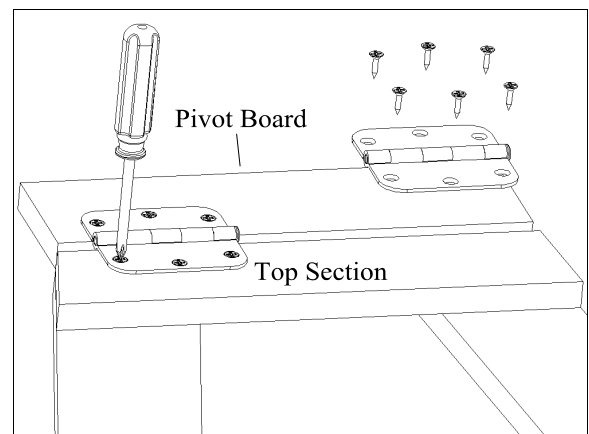

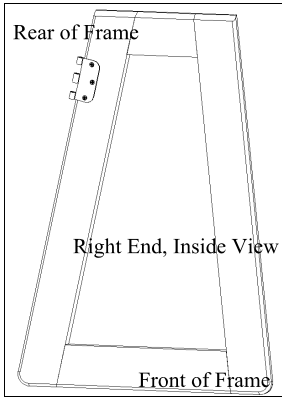

Step 13: Hinge to Legs

Remove the bolts from the other set of hinges. Mount half of the hinge on each leg as pictured.

Note: The hinge pin's shaft should be ground near the head (about 1" down) so it can easily be removed by hand. This will allow the brace to be removed easily so the frame can be folded and stored (see top next page).

Step 14: Pole Assembly

Assemble the poles to the pole mount ends. Put the rail hanger bolts through the sides and put on the lock nuts (see right).

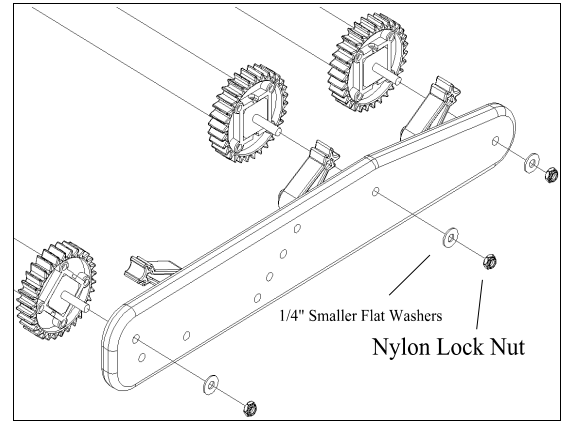

Step 15: Pole Assembly to Frame

Join the pole

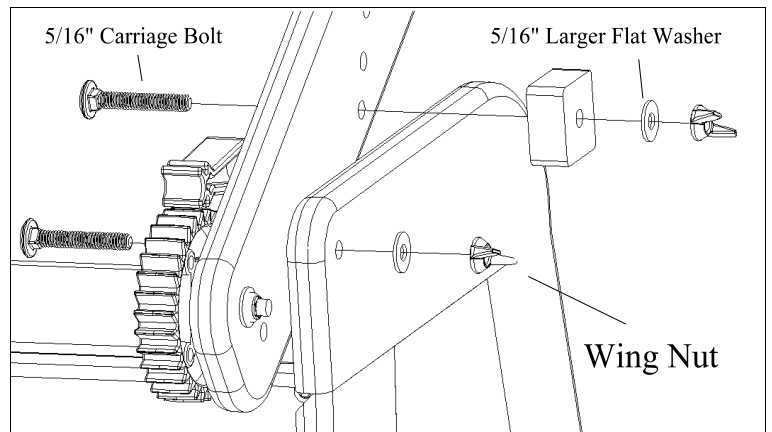
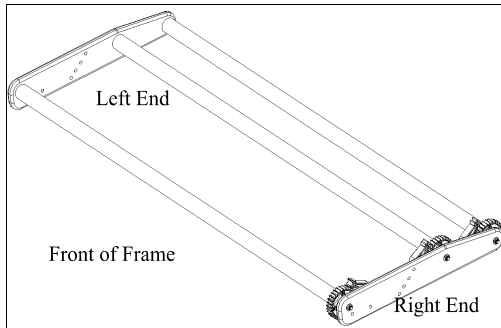

assembly to the frame sides with the two carriage bolts. Bolt on the pivot stop to the desired tilt setting.

Step 16: Brace Measurement

Straighten legs and measure the distance between the hinges on the legs for the brace.

Step 17: Cut brace.

Step 18: Mount Brace Hinges

Mount the remaining halves of the hinges to either end of the brace.

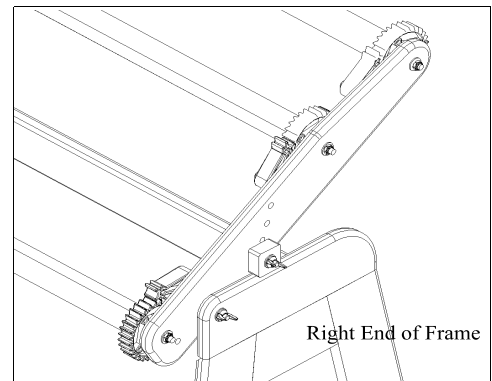

Step 19: Install Brace

Put the brace on by inserting the hinge bolt after it has been ground.

Your frame should now be complete!

