

Q'nique19X
ELITE

Instruction Manual

Grace
COMPANY

My Machine Details

Use this page to write down information about your machine. This will be helpful if you ever need to call a Grace Company support technician.

Machine Type: Q'nique 19X Elite

Machine Serial Number: _____

Date of Purchase: _____

What Frame are You Using? _____

Select Which Machine Accessories You Have Purchased:

Quilter's Creative Touch

Back Handles

Q'nique Laser Stylus

Magnifique Magnifying Glass

Ruler Base

Quilt Perfect Ruler Feet Kit

360 Wonder Foot

4 Piece Accessory Hopping Foot

9 Piece Accessory Hopping Foot

Thread Spool Accessory

Find your serial number on the silver sticker on the back of the machine.

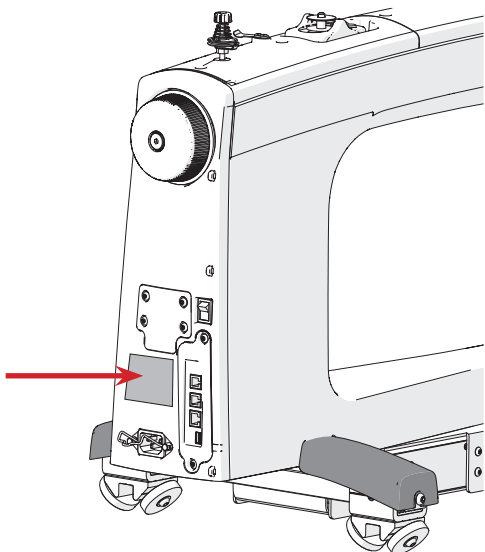

You may also be asked about your machine's firmware version. You can find this on the display after the machine is assembled and turned on. See page 87 for details.



Important Safeguards

When using an electrical appliance, basic safety precautions should always be followed, including the following.

DANGER - To reduce the risk of electric shock, do not leave the machine unattended when plugged in. Always unplug this machine from the electric outlet immediately after using and before cleaning.

WARNING - To reduce the risk of burns, fire, electric shock, or injury to persons:

- This appliance is not to be used by persons (including children) with reduced physical, sensory, or mental capabilities, or lack of experience and knowledge, unless they have been given supervision or instruction concerning use of the appliance in a safe way and understand the hazards involved.
- Children should be supervised to ensure that they do not play with the appliance. Children shall not play with the appliance.
- Cleaning and user maintenance shall not be made by children without supervision.
- Use this machine only for its intended use as described in this manual. Use only attachments recommended by the manufacturer as contained within this manual.
- Never operate this machine if it has a damaged cord or plug, it is not working properly, or it has been dropped, damaged, or dropped into water. Return the machine to the nearest authorized dealer or service center for examination, repair, or electrical or mechanical adjustment.
- Never operate the machine with any air openings blocked. Keep ventilation openings of the quilting machine free from the accumulation of lint, dust, and loose cloth.
- Never drop or insert any object into any opening.
- The appliance is intended for indoor use only. Do not use outdoors.
- Do not operate where aerosol (spray) products are being used or where oxygen is being administered.
- Connect this appliance to a properly grounded outlet only. See grounding instructions on next page.
- To disconnect, turn all controls to the off position, then remove the plug from the outlet by grasping the plug. Do not pull on cord. Always switch off or unplug the appliance when leaving it unattended.
- Do not unplug by pulling on cord. To unplug, grasp the plug, not the cord.
- If the supply cord is damaged, it must be replaced by the manufacturer, its service agent or similarly qualified persons in order to avoid a hazard.
- Keep fingers away from all moving parts. Special care is required around the quilting machine needle.
- Always use the proper needle plate. The wrong plate can cause the needle to break.
- Do not use bent or damaged needles.
- Do not pull or push fabric while stitching. It may deflect the needle, causing it to break.
- Switch the quilting machine off when making any adjustments in the needle area, such as threading the needle, changing the needle, or changing the presser foot, etc.
- Always unplug the quilting machine from the electrical outlet when removing covers, lubricating, or when making any other user servicing adjustments mentioned in the instruction manual.
- **CAUTION:** In order to avoid a hazard due to inadvertent resetting of the thermal cut-out, this appliance must not be supplied through an external switching device, such as a timer, or connected to a circuit that is regularly switched on and off by the utility.

If using this machine in an area with inconsistent input power, it is recommended the surge protector is connected to a backup battery supply.

In the instructions for electric sets shall indicate the sewing machine for which intended and how to be installed.

SAVE THESE INSTRUCTIONS! Do not discard box or packaging.

Important Safeguards (continued)

GROUNDING INSTRUCTIONS

This product must be grounded. In the event of malfunction or breakdown, grounding provides a path of least resistance for electric current to reduce the risk of electric shock. This product is equipped with a cord that has an equipment-grounding conductor and a grounding plug. Plug the cord from the quilting machine into a surge protector. The surge protector must be plugged into an appropriate outlet that is properly installed and grounded in accordance with all local codes and ordinances.

DANGER - Improper connection of the equipment-grounding conductor can result in a risk of electric shock. The conductor with insulation having an outer surface that is green, with or without yellow stripes, is the equipment-grounding conductor. If repair or replacement of the cord or plug is necessary, do not connect the equipment-grounding conductor to a live terminal. Check with a qualified electrician or serviceman if the grounding instructions are not completely understood, or if in doubt as to whether the product is properly grounded.

Do not modify the plug provided with the product - if it will not fit the outlet, have a proper outlet installed by a qualified electrician.

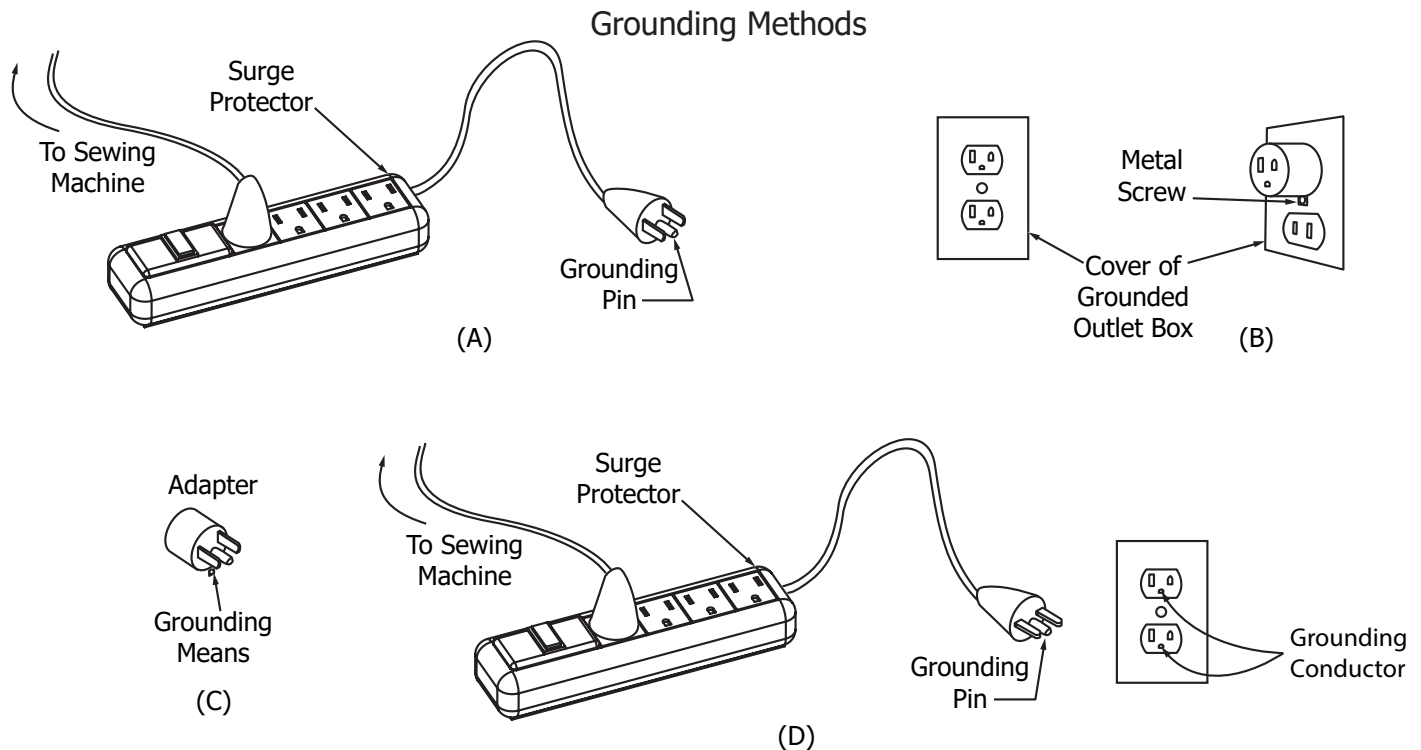

This product is for use on a nominal 120 V circuit, and has a grounding pin as illustrated above (A). A temporary adapter, shown in (B) and (C), may be used to connect this plug to a 2-pole receptacle (B) if a properly grounded outlet is not available. The temporary adapter should be used only until a properly grounded outlet can be installed by a qualified electrician. The green colored rigid ear, lug, and the like, extending from the adapter must be connected to a permanent ground such as a properly grounded outlet box cover. Whenever the adapter is used, it must be held in place by the metal screw.

A qualified electrician should be consulted if there is any doubt as to whether an outlet box is properly grounded.

Warranty Information

The Q'nique 19X Elite has a two-year limited warranty on all parts and a five-year limited warranty on its cast metal body. Under these warranties, Grace Company will at its discretion repair or replace any part(s) with material or manufacturing defect. The customer is required to return the product to Grace Company in its original box. If the customer does not have their original quilting machine box, they will need to buy a box from Grace Company to return their machine in. The customer is responsible for all shipping costs. Upon receipt of the product, Grace Company will determine whether to repair or replace the defective product or part(s). These warranties do not cover parts that are damaged through misuse, improper storage, improper assembly, loss, natural events, or willful destruction.

All customers requesting support will be required to provide a proof of purchase and registration if no warranty card is present and applicable. Grace Company product warranties are still valid if bought from an authorized Grace Company dealer. Grace Company is not subject to dealer warranties. Warranties do not transfer over to a secondary owner.

For more warranty and registration information, visit:

<https://graceframe.com/en/warranty/info>

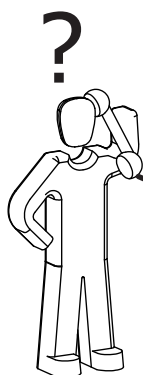
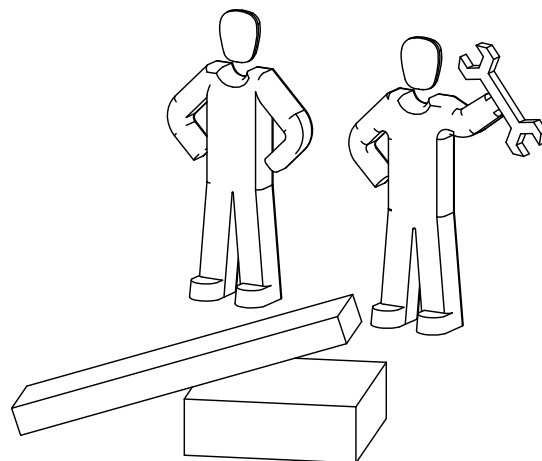
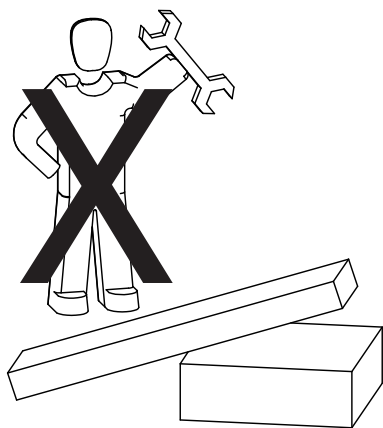

1-801-485-6688

Grace
COMPANY

Welcome to Your Q'nique 19X Elite

We are pleased to introduce you to the newest part of your quilting setup. This machine has been especially designed to help quilters like you have the tools available to create quality projects.

This manual is broken into four sections (or parts). Notifications at the end of each section will direct you to switch to your frame manual or Quilter's Creative Touch (QCT, previously called QuiltMotion) manual for instructions on assembling those products. This creates a streamlined process of building a complete quilting setup in the most efficient way. Use the following flowchart to guide you in navigating multiple manuals. If you are not using one of the products in the flowchart, just move to the next item in the chart.

Thank you again for choosing us to help with your quilting projects.

- The Grace Company

Start Here: Frame Manual: Part One

- Assemble the frame's legs, table, and sides.
- Install the channel lock onto the bottom carriage.
- Align your tracks.

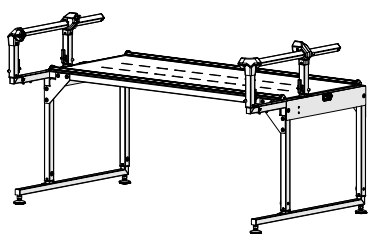

Quilting Machine Manual: Part One

- Install the lower encoder onto the bottom carriage.

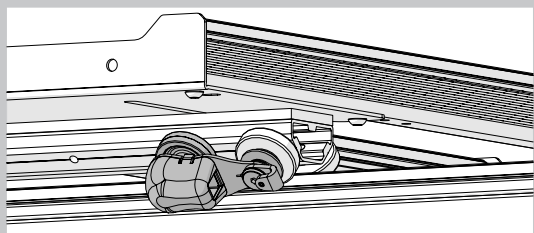

QCT Manual: Part One

- Prepare the bottom carriage.
- Install the long belt across the frame.

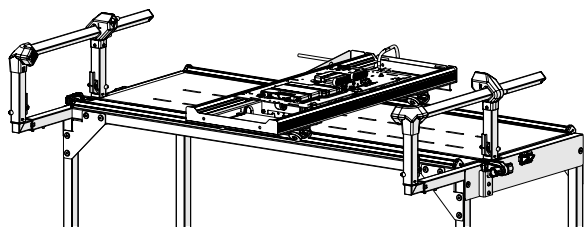

Quilting Machine Manual: Part Two

- Install your machine's wheels.
- Align your wheels.

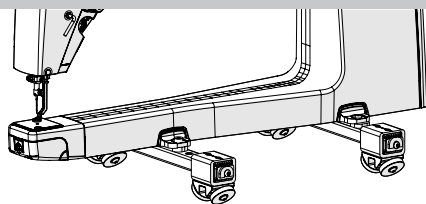

QCT Manual: Part Two

- Install the short belt.
- Tension the short belt.

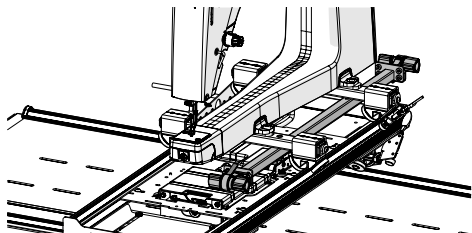

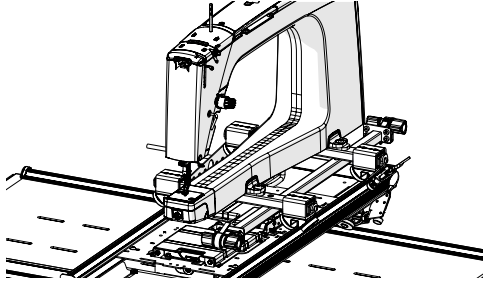

Frame Manual: Part Two

- Install the channel lock on the machine or top plate.
- Prepare the top plate and home sewing machine.
- Place the machine or top plate on the frame.

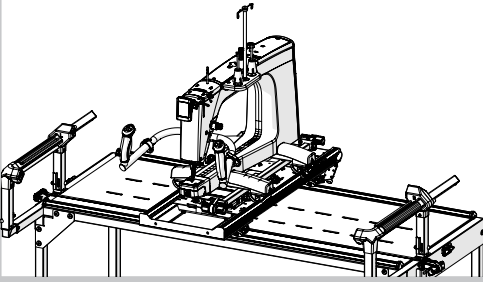

Quilting Machine Manual: Part Three

- Install the wheel covers, display, handles, thread mast.
- Install the upper encoder.

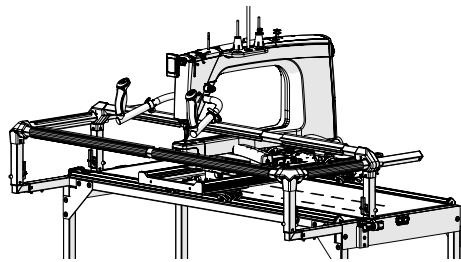

Frame Manual: Part Three

- Install the rails and fabric bungees.
- Position and adjust the rails.
- Adjust the carriage stop.
- Level the frame.

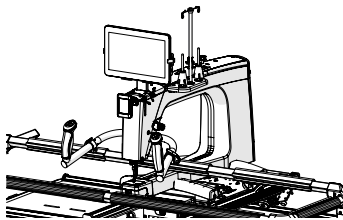

QCT Manual: Part Three

- Install the tablet bracket.
- Plug in Quilter's Creative Touch.

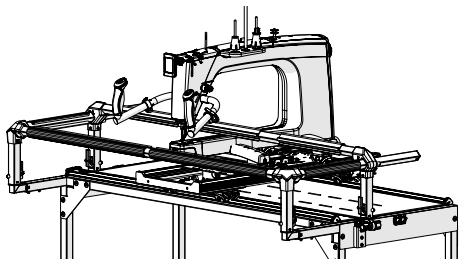

Frame Manual: Part Four

- Install the velcro tape
- Install the cloth leaders
- Attach the fabric

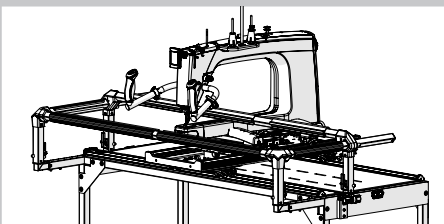

Quilting Machine Manual: Part Four

- Use the quilting modes and settings in the display.
- Maintain the machine and perform repairs.

Table of Contents

Important Safeguards	i	Tracking Stitch Count & Run Time	66
Warranty Information	iii	Getting Started	67
Welcome to Your Q'nique 19X Elite....	iv	Maintaining the Machine	71
Machine Specifications.....	vii	Preparing the Oil Bottle	72
Machine Layout.....	viii	Oiling and Cleaning	73
Ports and Plug-Ins.....	x	Changing the Needle	76
Included Parts & Tools	xii	Adjusting the Hopping Foot.....	78
Animated Instructions	xvi	Reinstalling the Needle Plate	83
Out-of-the Box Assembly	xvi	Re-assembling the Thread Tensioner	85
Part One	1	Repairs and Diagnostics	86
Task 1 - Installing the Lower Encoder	2	Checking the Firmware	87
Part Two	11	Troubleshooting Bobbin Wind.....	88
Task 2 - Installing the Wheels	12	Replacing the Encoder Spring.....	90
Part Three.....	17	Reinstalling the Hook Holder	93
Task 3 - Installing the Wheel Covers	18	Timing the Machine.....	96
Task 4 - Assembling the Handlebars	20	Appendix.....	100
Task 5 - Connecting the Display	23	Choosing Your Needle	101
Task 6 - Attaching the Thread Stand.....	25	Choosing Your Thread	103
Task 7 - Installing the Upper Encoder	26	Choosing Your Fabric and Batting	106
Task 8 - Turning the Machine On/Off	28	Troubleshooting Guide.....	107
Preparing to Quilt	29	Index.....	109
Help Guides.....	30		
Task 9 - Winding a Bobbin	31		
Task 10 - Loading the Bobbin Case	34		
Task 11 - Threading the Machine	37		
Part Four.....	42		
Quilting	43		
Choosing Machine Settings	44		
Using the Handlebar Controls.....	46		
Using the Precise Quilting Mode	47		
Using the Cruise Quilting Mode	49		
Using Manual Quilting Mode.....	51		
Using Baste Quilting Mode	53		
Using the Bobbin Estimator Tool.....	55		
Using the Edge Warning	57		
Adjusting Thread Tension	60		
Taking Measurements	63		
Making Calculations.....	65		

Machine Specifications

Patent: WO 2013/070633 AI
Additional Patents Pending

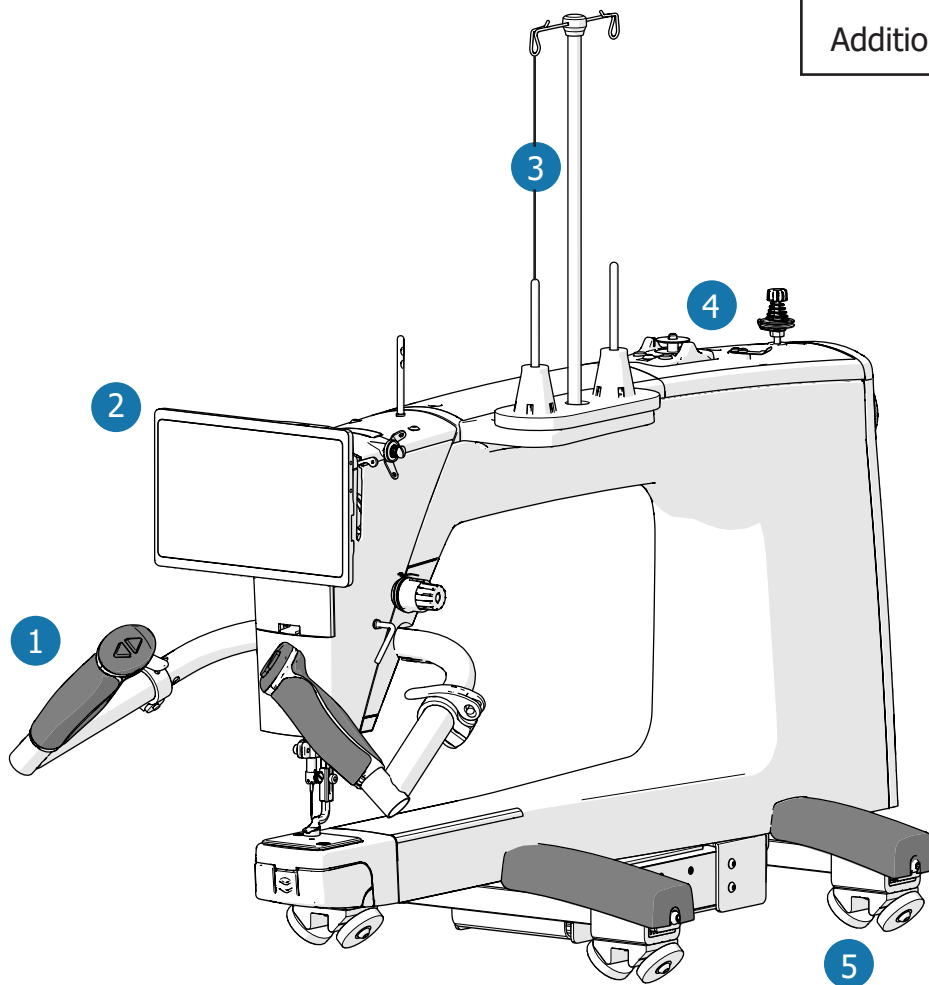

Product Dimensions

Body:

- Height: 680.2 mm, or 26.8 inches
- Width: 395.4 mm, or 15.6 inches
- Length: 831.9 mm, or 32.8 inches
- Weight: 19.7 kg, or 43.5 lbs

Quilting Arm:

- Height: 224.8 mm, or 8.9 inches
- Length: 482.6 mm, or 19 inches

Electrical

- Input Voltage: 110-220 VAC
- Peak Power Consumption: 450 W

Features

- 1 Adjustable handles for comfortable extended use (page 20)
 - 2 7" Touch Display (page 23)
 - 3 Dual thread mast and stands for quilting and winding bobbin at the same time
 - 4 Built-in bobbin winder (page 31)
 - 5 Dual wheels for stability (page 12)
- Stitches per minute (SPM) range of 90 to 2600 stitches
 - Regulated stitching
 - Quilt-edge warning feature

Machine Layout

Quilting Machine (Side View)

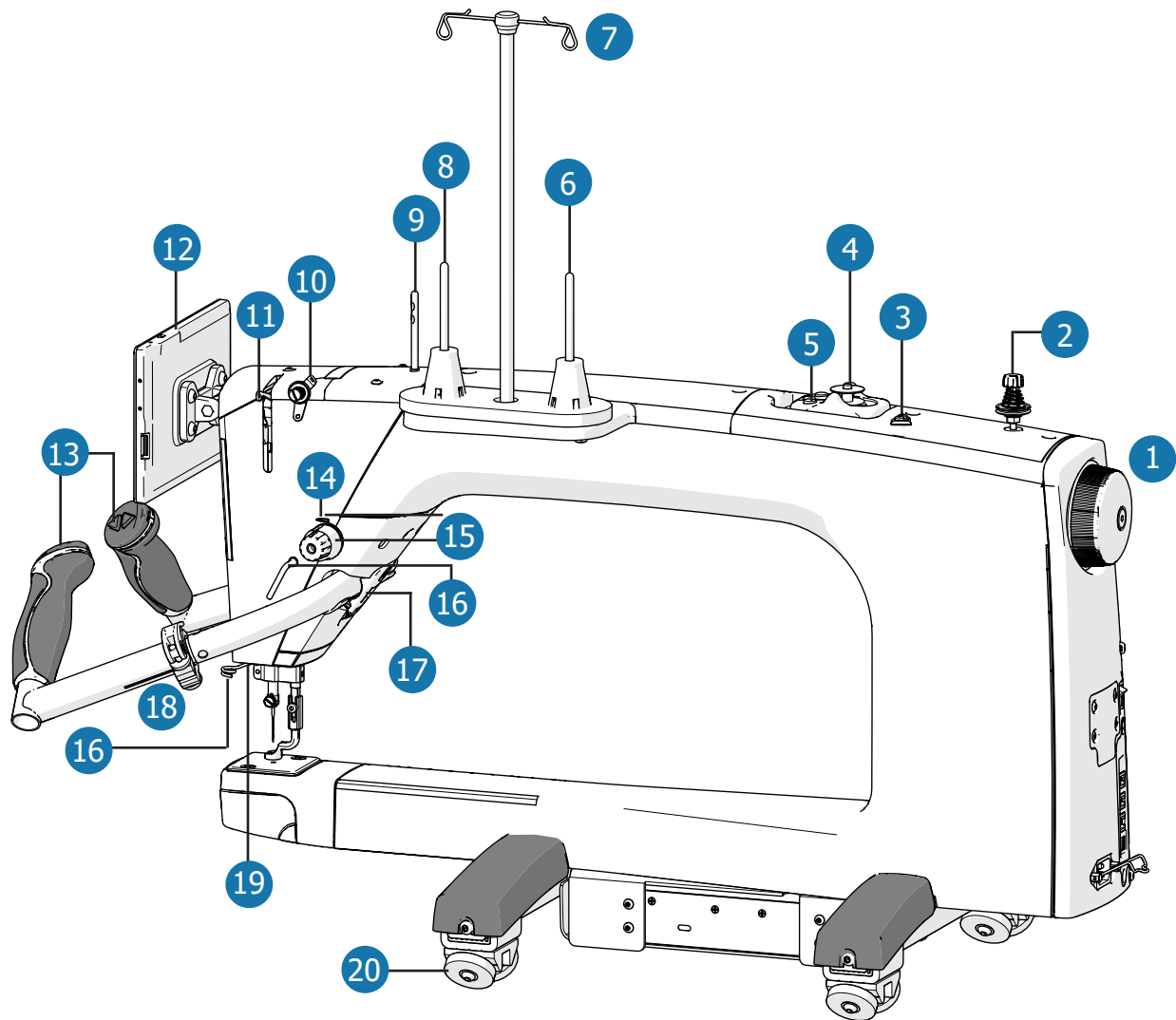

- 1 Hand Wheel**
Raises and lowers the needle bar.
- 2 Bobbin Thread Tensioner** (page 31)
Tensions thread when winding a bobbin.
- 3 Bobbin Thread Cutter** (page 31)
Cuts wound bobbin thread.
- 4 Bobbin Stand** (page 31)
Holds the bobbin for winding.
- 5 Bobbin Winder Buttons** (page 31)
Start and stop bobbin winding.
- 6 Bobbin Wind Thread Stand** (page 31)
Holds a cone of thread for winding bobbin.
- 7 Thread Mast** (page 25)
Guides thread when quilting.
- 8 Top Thread Stand** (page 37)
Holds a thread cone for threading machine.
- 9 Thread Guide Rod** (page 37)
Positions thread when quilting.
- 10 Small Thread Tensioner** (page 37)
Tensions thread when quilting.
- 11 Take-Up Lever** (page 37)
Tensions thread when quilting.
- 12 7" Touch Display** (page 23)
Provides access to quilting options.

- 13 Handlebar Controls** (page 20)
Controls machine functions.
- 14 Tensioner Check Spring** (page 37)
Applies additional tension to thread.
- 15 Large Thread Tensioner** (page 60)
Tensions thread as adjusted when quilting.
- 16 Thread Guides** (page 37)
Positions thread when quilting.
- 17 Handle Bar Clamp** (page 20)
Used to adjust handlebar position.
- 18 Handle Bar Levers** (page 20)
Used to adjust handle position.
- 19 Lamp** (page 44)
Lights up needle area when machine is on.
- 20 Machine Wheels** (page 12)
Shuttles the machine up and down the bottom carriage.

Hook Assembly (Front View)

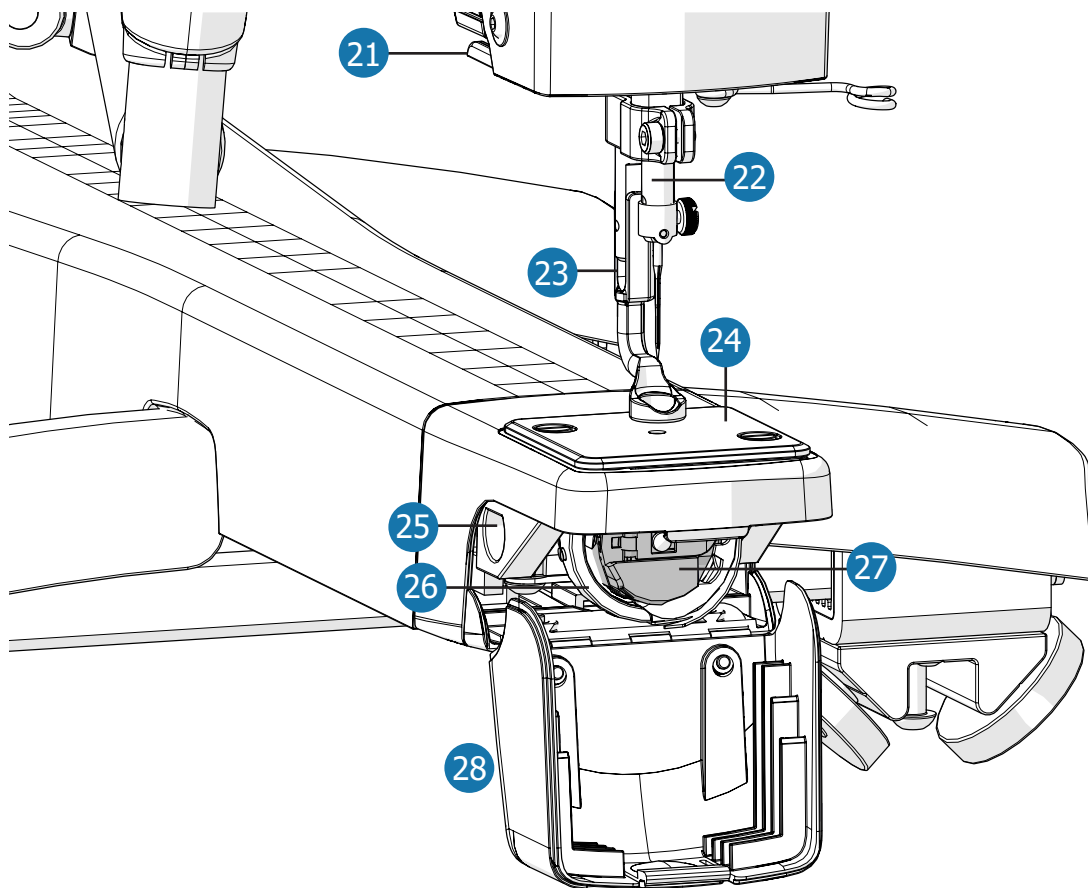

- 21 Thread Cutter** (page 34)
Cuts excess thread from threading machine.
- 22 Needle Bar** (page 76)
Holds the needle when quilting.
- 23 Hopping Foot** (page 78)
Presses fabric down when quilting.
- 24 Needle Plate** (page 83)
Covers top of hook assembly.
- 25 Timing Cut-Out** (page 78)
Accesses hook assembly set screws.
- 26 Hook Assembly** (page 34)
Holds the bobbin case and hooks the top thread to create stitches.
- 27 Bobbin Case** (page 31)
Holds M-class bobbin and controls bottom thread tension.
- 28 Hook Assembly Cover** (page 34)
Covers the hook assembly area.

Ports and Plug-Ins

Machine Rear (Underside View)

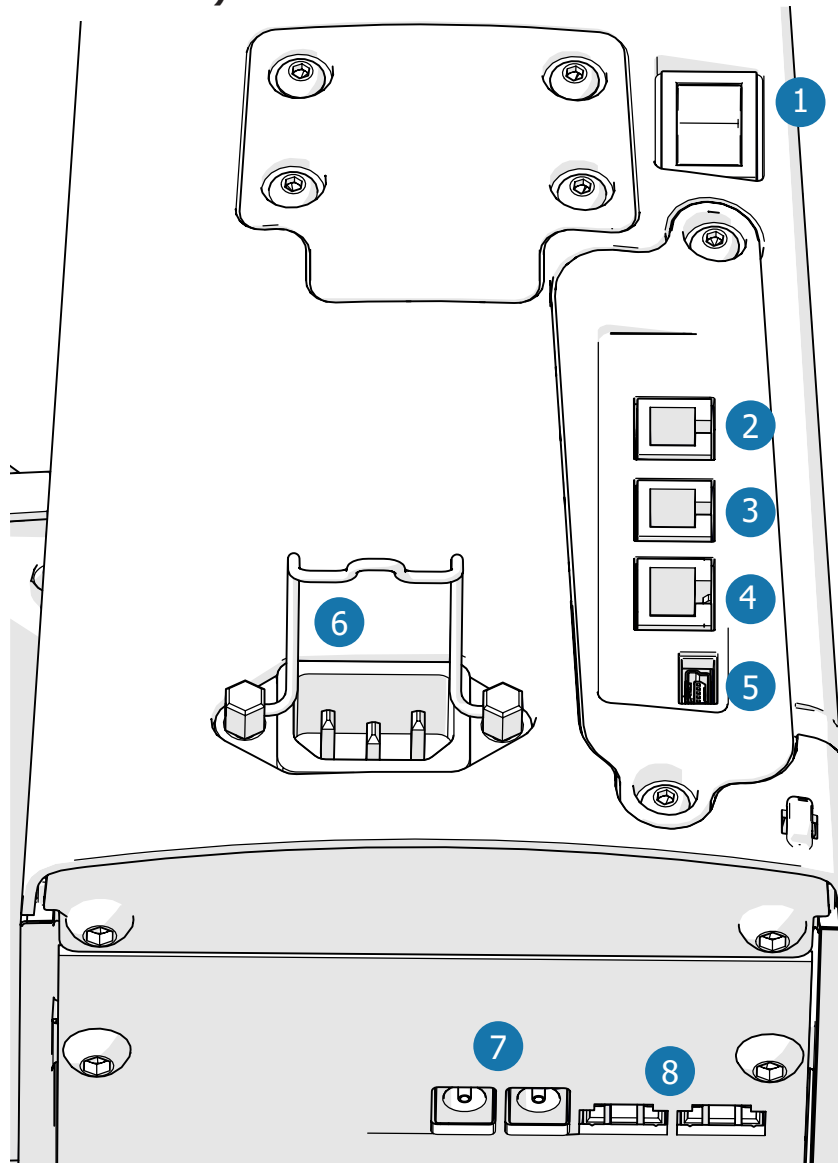

1 Power On/Off Switch (page 28)
Turns machine on and off.

2 Lower Encoder Port (page 27)
Connects encoders to machine.

3 Upper Encoder Port (page 27)
Connects encoders to machine.

4 Quilter's Creative Touch (previously called QuiltMotion) Tablet Port
For optional automation accessory.

5 USB Connector Port
For updating only.

6 Power Port with Retainer (page 28)
Connects and holds power cable to the machine.

7 Accessory Ports
For laser accessory.

8 Back Handle Ports
For back handle accessory.

Machine Front

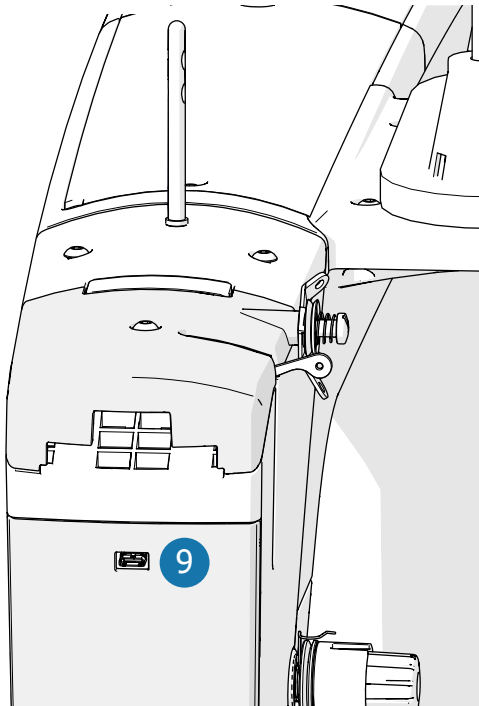

- 9 **Display Cable Port** (page 23)
Connects display cable to machine.

Machine Throat

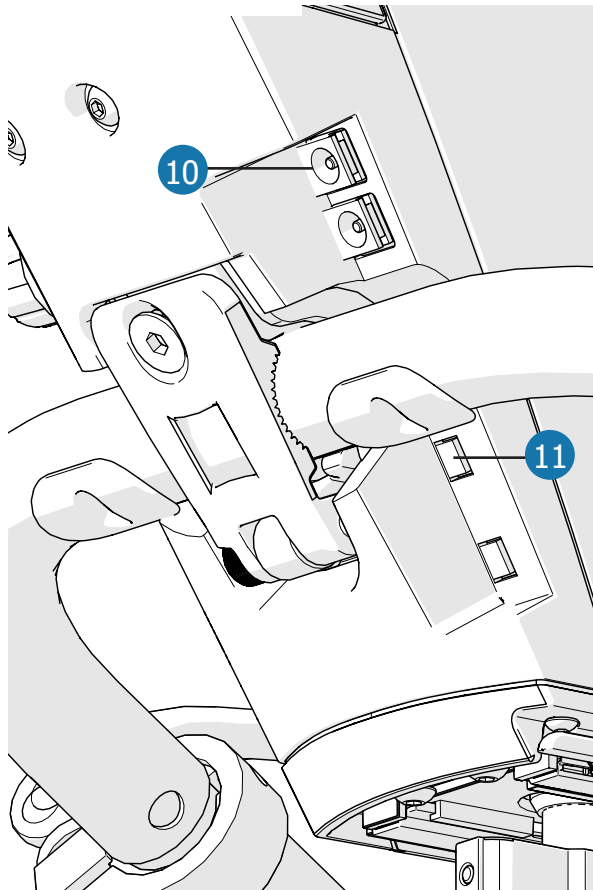

- 10 **Accessory Ports**
For laser accessory.
- 11 **Handlebar Ports** (page 20)
Connects handlebar controls to machine.

Included Parts & Tools

Level One (Workstation)

Tip: Parts are grouped together in the packaging for your convenience. For the best experience, do not remove parts from the packaging until instructed to do so.

Back Wheel Base Assembly

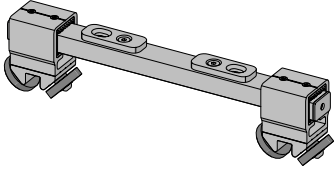

SMP-09-14385
See page 12

Front Wheel Base Assembly

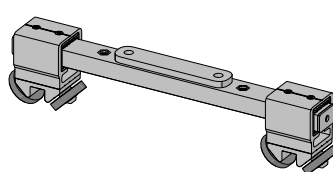

SMP-09-14386
See page 12

Tools Box

T-handle Allen Wrench 4 mm

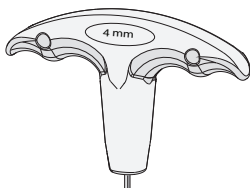

HDW-03-13114

T-handle Allen Wrench 3 mm

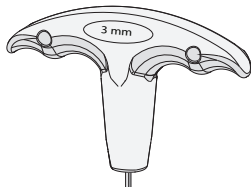

HDW-03-13115

T-handle Allen Wrench 2.5 mm

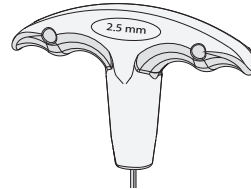

HDW-03-13116

T-handle Allen Wrench 2 mm

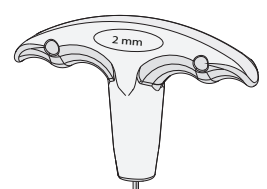

HDW-03-13117

Flat-head Screwdriver

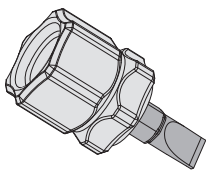

SMP-03-10169
See page 83

Timing Spacer

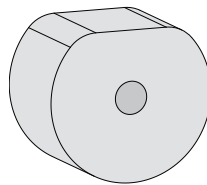

SMP-03-11320
See page 96

M Class Bobbin

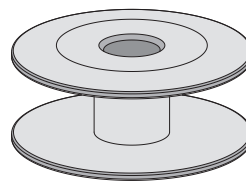

SMP-08-10070
See page 31

Needle Magnet

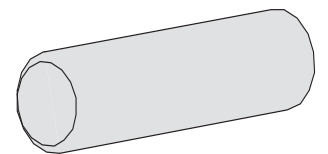

SMP-09-13837
See page 76

Lint Brush

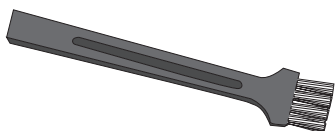

SMP-03-10170
See page 73

Hopping Foot Height Tool



SMP-03-12171
See page 78

Needle Size 18 (one 10-pack) (one pre-installed)

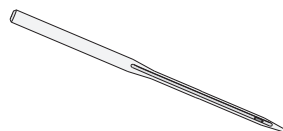

ACC-01-14517
See page 76

Needle Size 16 (one 10-pack)

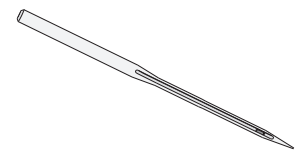

ACC-01-14516
See page 76

**Allen Wrench
5 mm**



HDW-03-10741

Encoder Box

**Upper Encoder
(silver spring)**

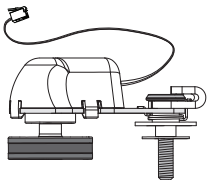

SMP-09-15701
See page 26

**Lower Encoder
(black spring)**

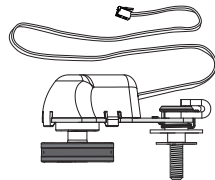

SMP-09-15700
See page 2

Zip Tie Mount (x2)

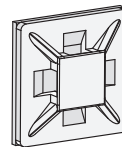

MIS-08-10805

**Lower Encoder
Spring (black)**

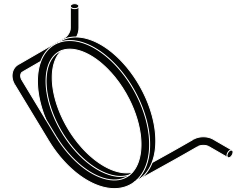

HDW-03-10671
See page 90

**Upper Encoder
Spring (silver)**

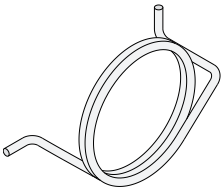

HDW-03-10216
See page 90

Wheel Base Hardware Box

**SBHCS Screw
M6 x 25 mm (x2)**

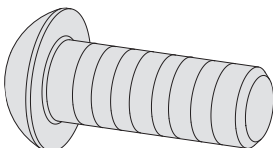

HDW-03-10215
See page 12

**Shoulder Bolt
M6 (x2)**

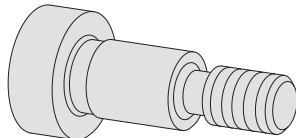

HDW-03-12206
See page 12

**Allen Wrench
4 mm**

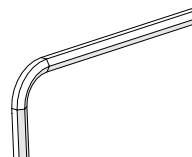

HDW-03-10167
See page 12

Included Parts and Tools (continued)

Wheel Base Cover Box

**Front Left Wheel
Base Cover**

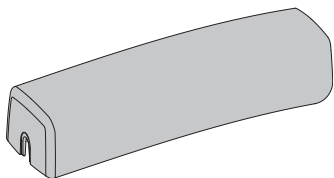

SMP-05-12166
See page 18

**Front Right Wheel
Base Cover**

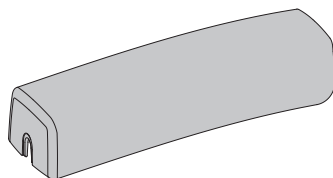

SMP-05-12167
See page 18

**Back Left Wheel
Base Cover**

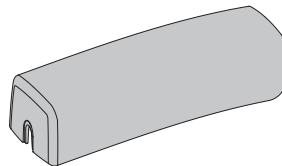

SMP-05-12164
See page 18

**Back Right Wheel
Base Cover**

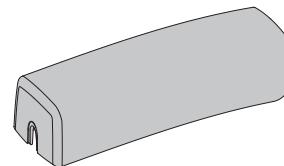

SMP-05-12165
See page 18

**SBHCS Screw
M6 x 16 mm (x4)**

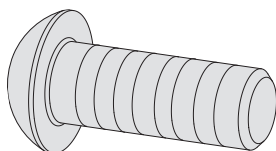

HDW-03-10974
See page 18

Display Box

7 Inch Touch Display

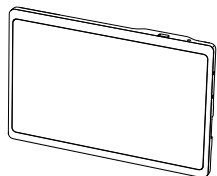

SMP-09-15576
See page 23

**SBHCS
M5 x 16 mm (x2)**

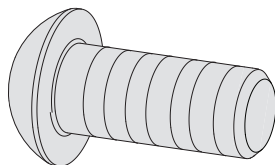

HDW-03-10857
See page 23

Thread Stand Hardware Box

**SBHCS Screw
M4 x 8 mm (x2)**

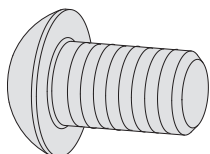

HDW-03-10012
See page 25

Power Cord/Oil Bottle Box

Power Cord

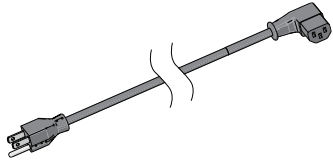

SMP-02-14466
See page 28

Oil Bottle

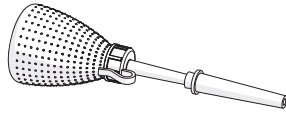

SMP-09-13888
See page 72

Thumb Screw M3 (needle bar spare)

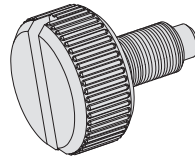

HDW-03-11736
See page 76

Hopping Foot Screw

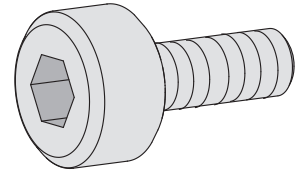

HDW-03-10966
See page 78

Level Two

Thread Stand Assembly

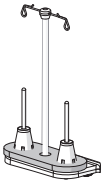

SMP-09-14104
See page 25

Handlebar Assembly

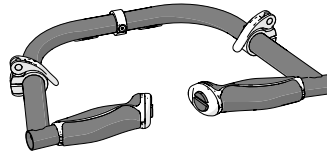

SMP-09-14066
See page 20

Sample Thread Kit Box

Sample Thread Kit

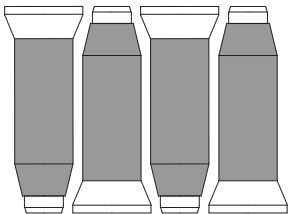

MIS-11-16122

Animated Instructions

To provide the best possible customer experience, we also offer animated video instructions for setting up this product. To view the animated instructions, visit our website at:

<https://l.ead.me/19xelitestart>.

You can also use your smartphone to scan this QR code:



Out-of-the Box Assembly

This section of the manual covers all the steps to assemble the machine after you bring it home for the first time.

Task 1 - Installing the Lower Encoder	page 2
Task 2 - Installing the Wheels	page 12
Task 3 - Installing the Wheel Covers.....	page 18
Task 4 - Assembling the Handlebars	page 20
Task 5 - Connecting the Display	page 23
Task 6 - Attaching the Thread Stand	page 25
Task 7 - Installing the Upper Encoder	page 26
Task 8 - Turning the Machine On/Off	page 28

Part One

Before completing the tasks in Part One of your machine instructions, please complete Part One of your frame instructions.

Progress Checkpoint:

Have you:

- Assembled your frame's legs and table?
- Installed and align the frame tracks?
- Installed the channel lock on the bottom carriage?
- Installed the rail supports?

Note: Do not install the rails at this time.

If you've already fully assembled your frame, uninstall your frame's take-up rail.

Task 1 - Installing the Lower Encoder

Parts & Tools Needed:

Lower Encoder
(black spring)

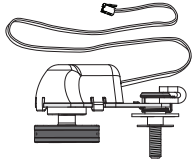

Encoder Box

T-handle Allen
Wrench 4 mm

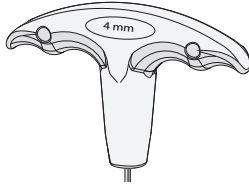

Tools Box

T-handle Allen
Wrench 2.5 mm

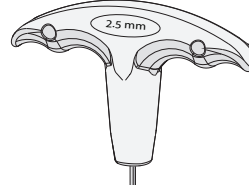

Tools Box

Allen Wrench
5 mm



Tools Box

Instructions

The encoders monitor the position of the machine over the frame, allowing for regulated stitching. The lower encoder is installed on the left-rear wheel of your frame's bottom carriage. Please take the following steps to install the encoder onto the bottom carriage:

- 1 The parts and tools needed for this step are located in the **encoder and tools boxes**. The lower encoder has the black spring and green sticker.

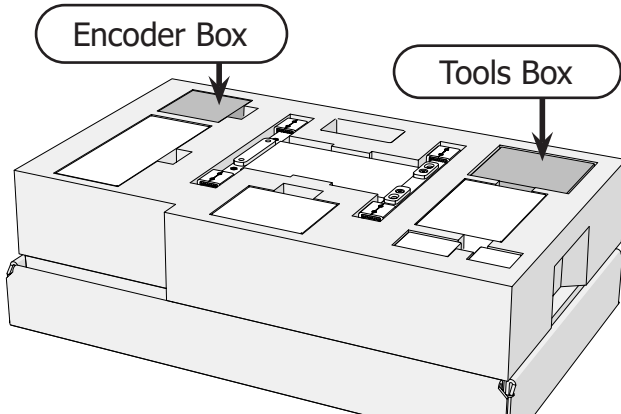

- 2 Loosen the **lock collar screw** on the lower encoder with the 2.5 mm Allen wrench until the **lock collar** (shown in blue) turns freely.

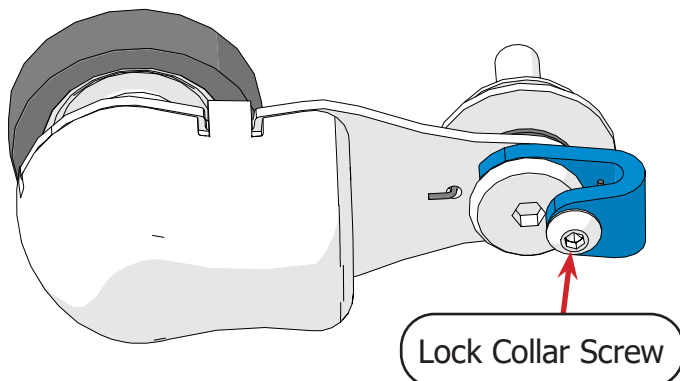

- 3 Locate the back left wheel of your bottom carriage. **Note:** If needed, review your frame assembly manual to determine the front of the bottom carriage.

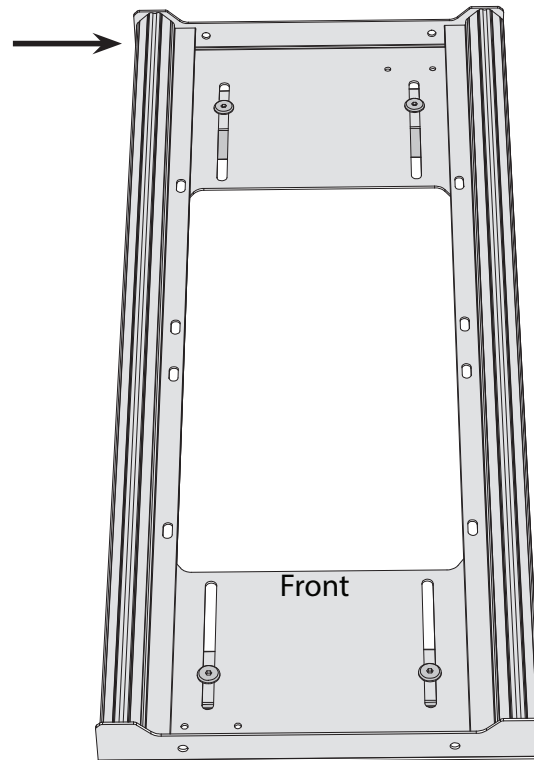

Note: Bottom carriage appearance varies by model.

- 4 There are four types of bottom carriage you might have. Review the characteristics below to determine which type is yours, and then follow the directions for your type.

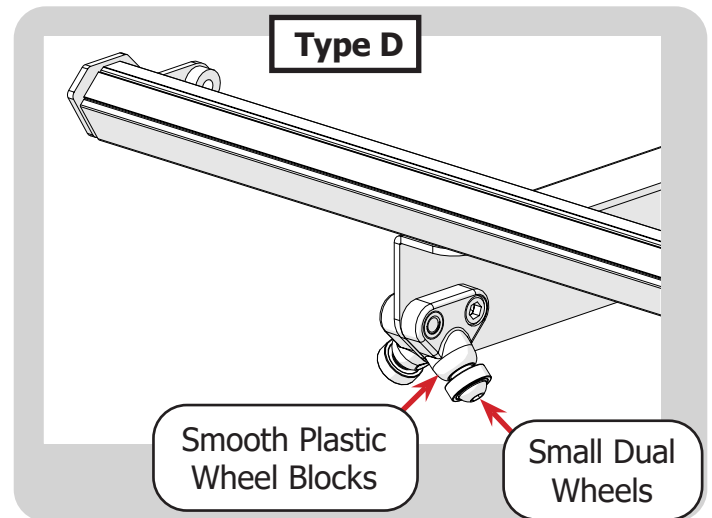
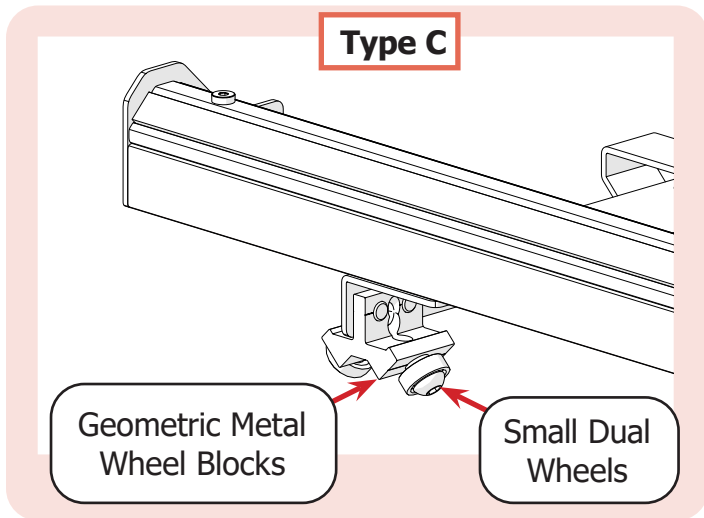
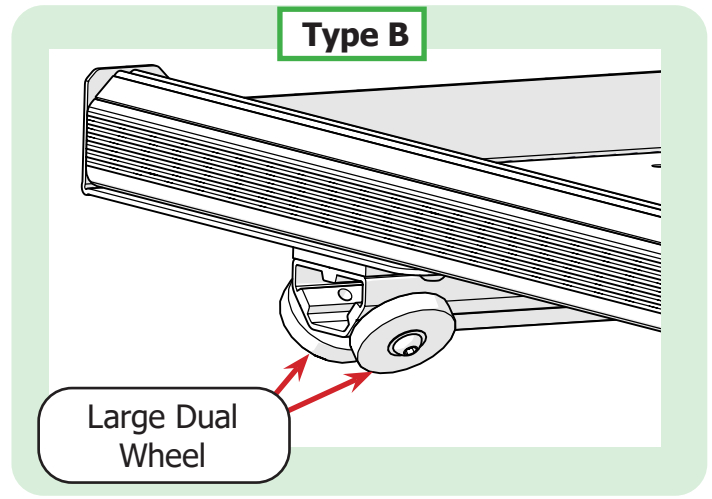
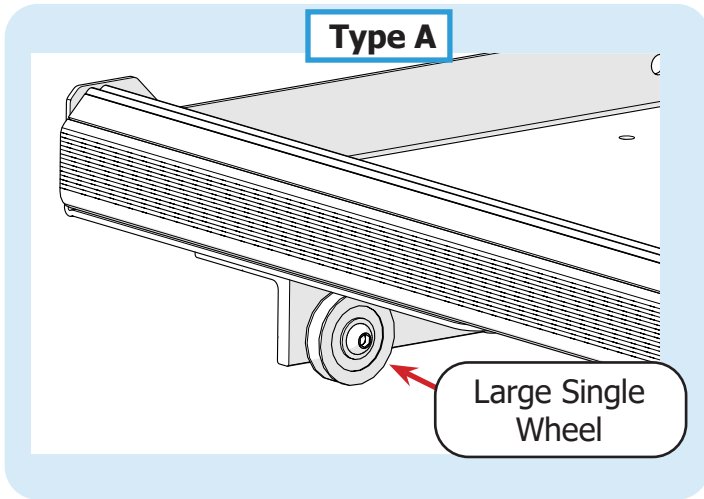

Type A

a Use the 4 mm Allen wrench to remove the left-rear **wheel** and **spacer** from the bottom carriage.

Spacer

Wheel

Wheel Screw

Note: The **wheel screw** is not needed again and can be stored with the packaging materials.

This diagram shows a side view of a Type A bottom carriage. A blue wheel and a blue spacer are being removed from the carriage. A red arrow points from the text label to the wheel. Another red arrow points from the text label to the wheel screw. A third red arrow points from the text label to the spacer.

Installing the Lower Encoder (continued)

- b) Install the **wheel** and then the **spacer** onto the encoder bolt.

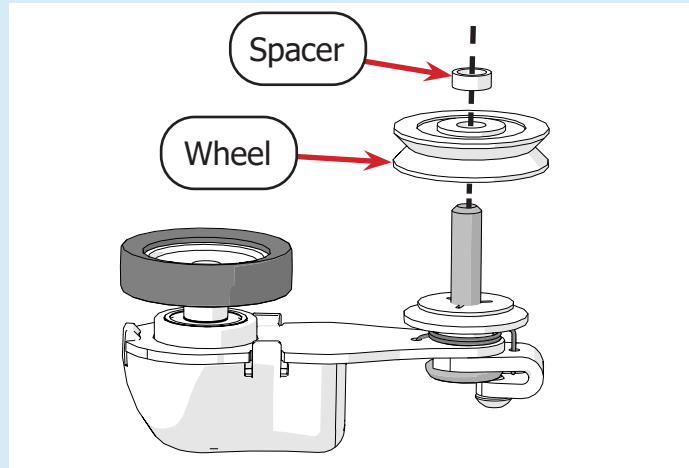

- c) With the 4 mm Allen wrench, screw the encoder into the left rear wheel hole on the carriage so the **encoder wheel** is between the rear wheels.

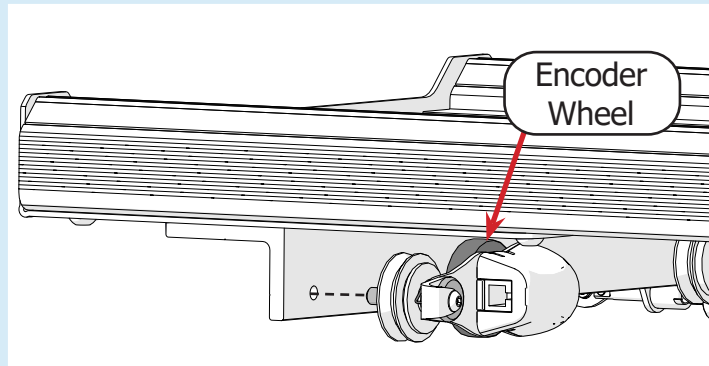

- d) Turn the encoder **lock collar** (shown in blue) to point up. Then tighten the **lock collar screw** with the 2.5 mm Allen wrench.

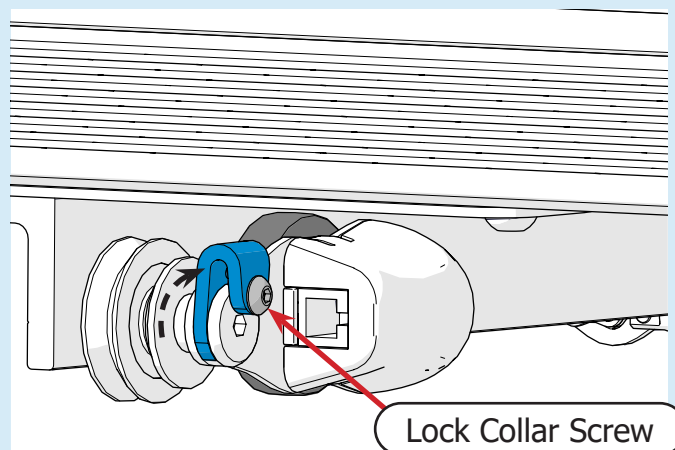

- e Take the free end of the **encoder cable** (shown in blue) and pull it through the slot in the bottom carriage behind the wheels.

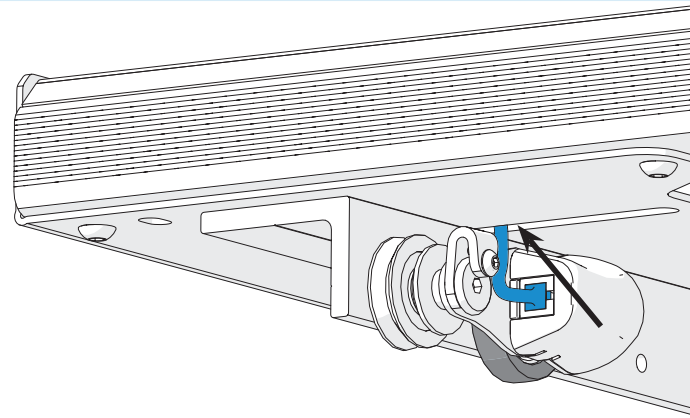

Note: Instructions for plugging the encoder cable into the machine are covered in "Task 7" after the machine has been installed.

Type B

- a Use the 4 mm Allen wrench to remove the outward-facing left rear **wheel** from the bottom carriage.

Note: The **wheel screw** is not needed again and can be stored with the packaging materials.

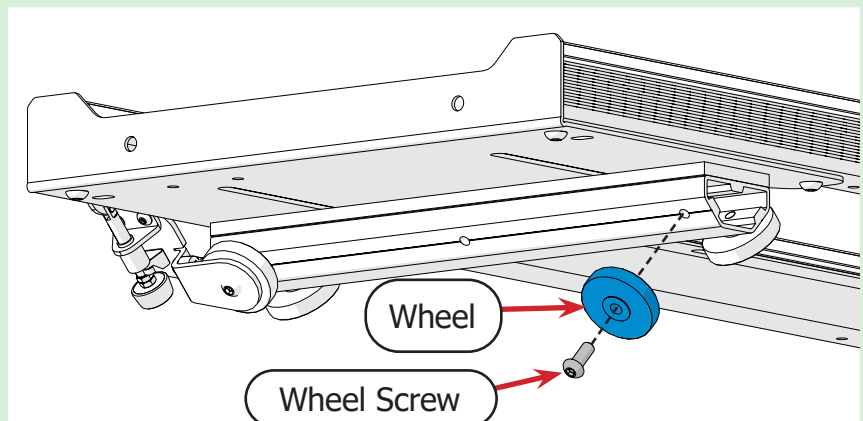

- b Install the wheel onto the encoder bolt so the **wheel hub** is away from the encoder.

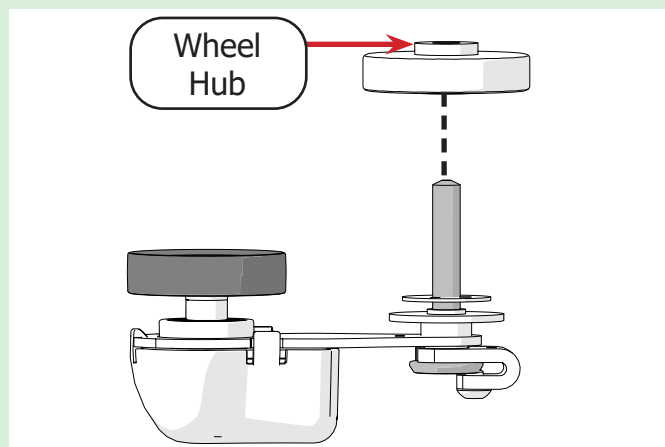

Installing the Lower Encoder (continued)

- c With the 4 mm Allen wrench, screw the encoder into the left rear wheel hole on the carriage so the **encoder wheel** is between the rear wheels.

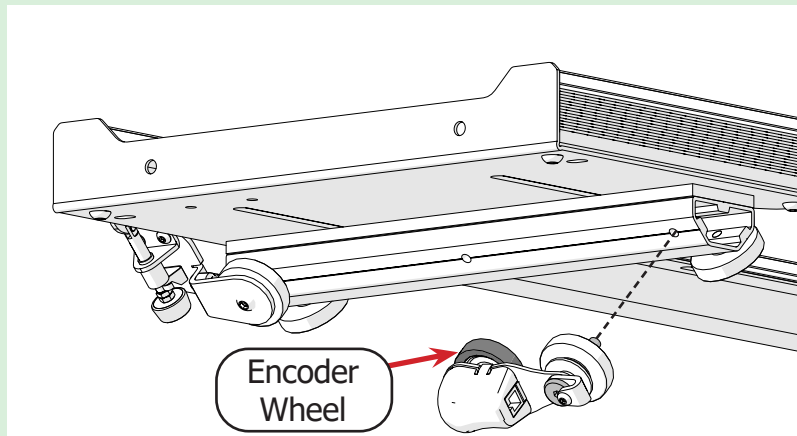

- d Turn the encoder **lock collar** (shown in blue) to point up. Then tighten the **lock collar screw** with the 2.5 mm Allen wrench.

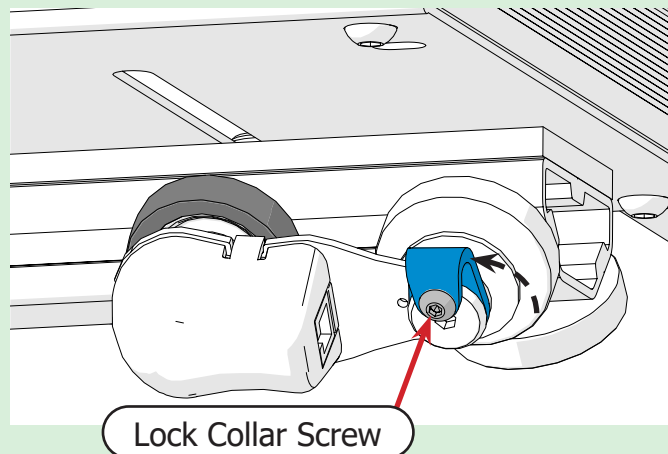

- e Take the free end of the **encoder cable** (shown in blue) and pull it through the slot in the bottom carriage behind the wheels.

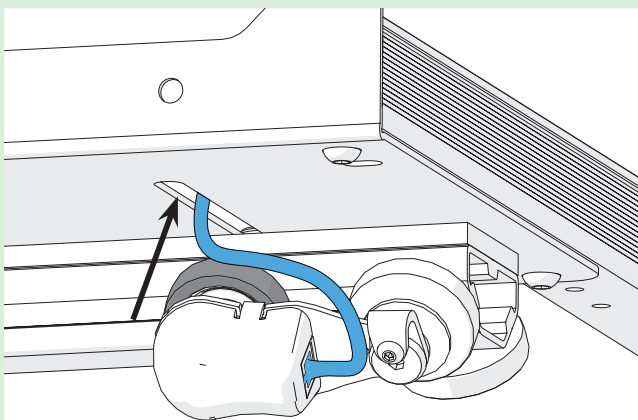

Note: Instructions for plugging the encoder cable into the machine are covered in "Task 7" after the machine has been installed.

Type C

- a Ensure the lower **encoder bracket** has been installed on the back of your bottom carriage. These steps are covered in your frame's instruction manual.

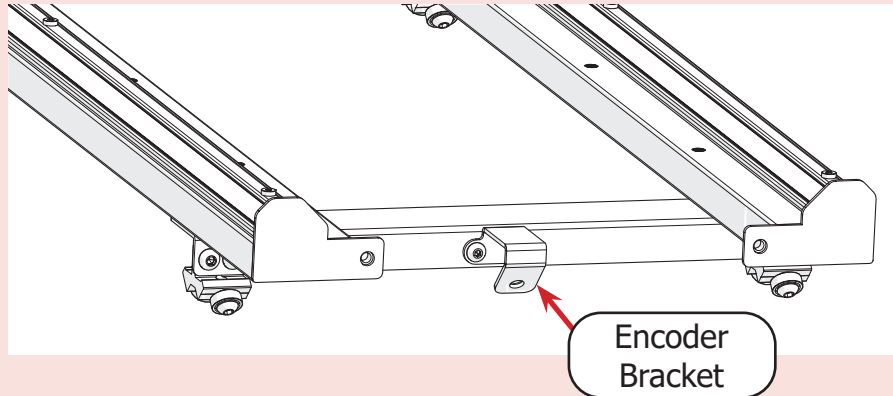

- b Install the encoder directly onto the encoder bracket at the rear of the carriage so the **encoder wheel** is to the left of the bracket. Tighten with the 4 mm Allen wrench.

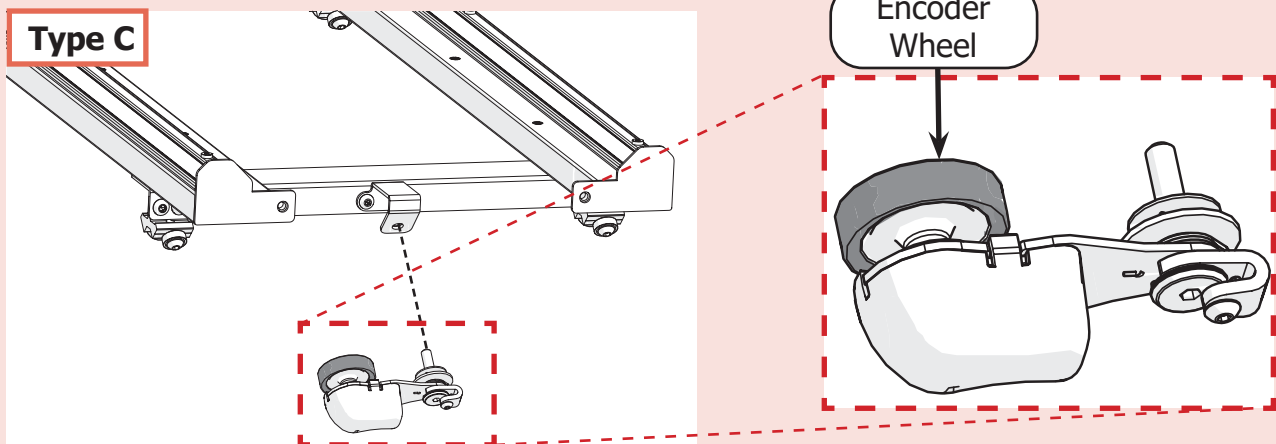

- c Turn the encoder **lock collar** (shown in blue) to point up. Then tighten the **lock collar screw** with the 2.5 mm Allen wrench.

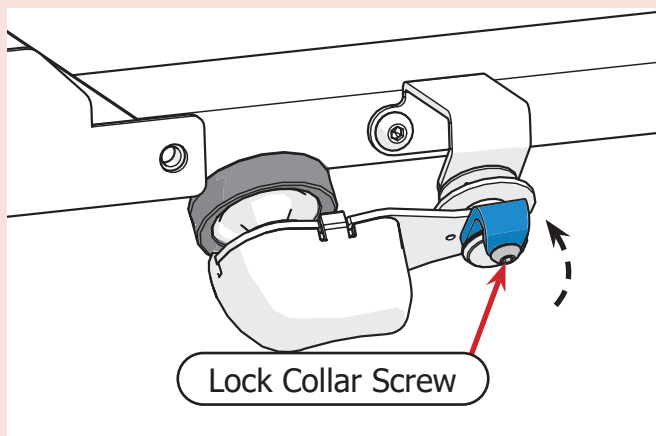

Note: Instructions for plugging the encoder cable into the machine are covered in "Task 7" after the machine has been installed.

Type D

- a Locate the **back-right wheels** of the bottom carriage.

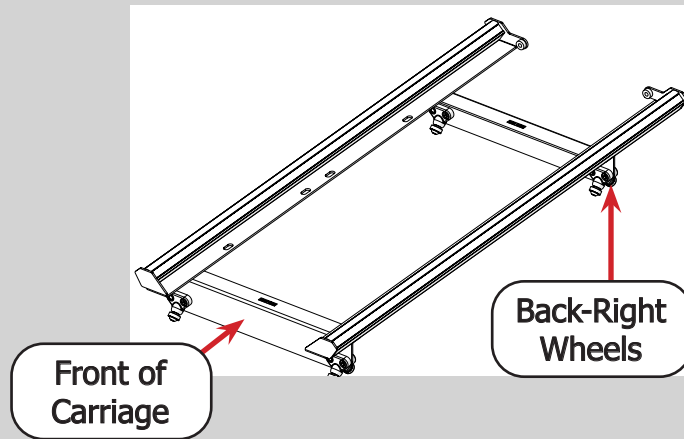

- b Use the 5 mm Allen Wrench to remove the **wheel screw** and the **M6 spacer** from the back of the back-right **wheel holder**.

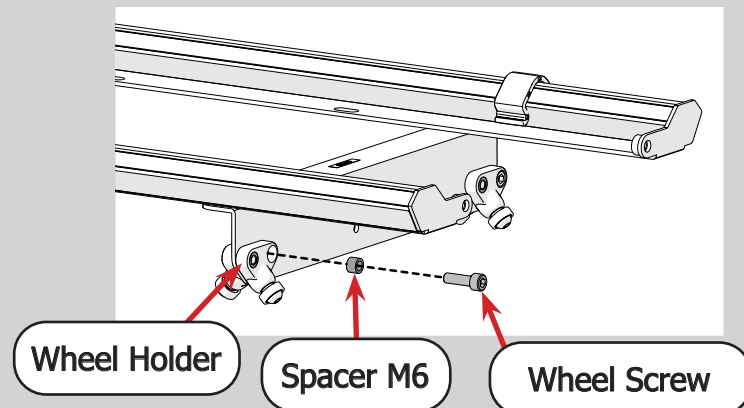

Note: The **wheel screw** is not needed again and can be stored with the packaging materials.

- c Install the **M6 spacer** onto the **encoder bolt**.

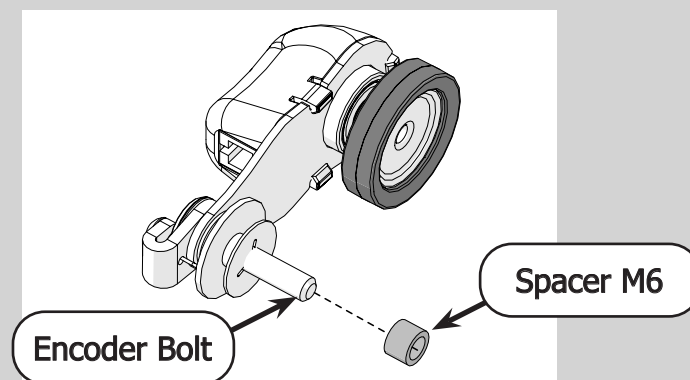

- d) Install the encoder directly onto the wheel holder at the rear of the carriage so the **encoder wheel** is to the left of the bracket. Tighten with the 4 mm Allen wrench.

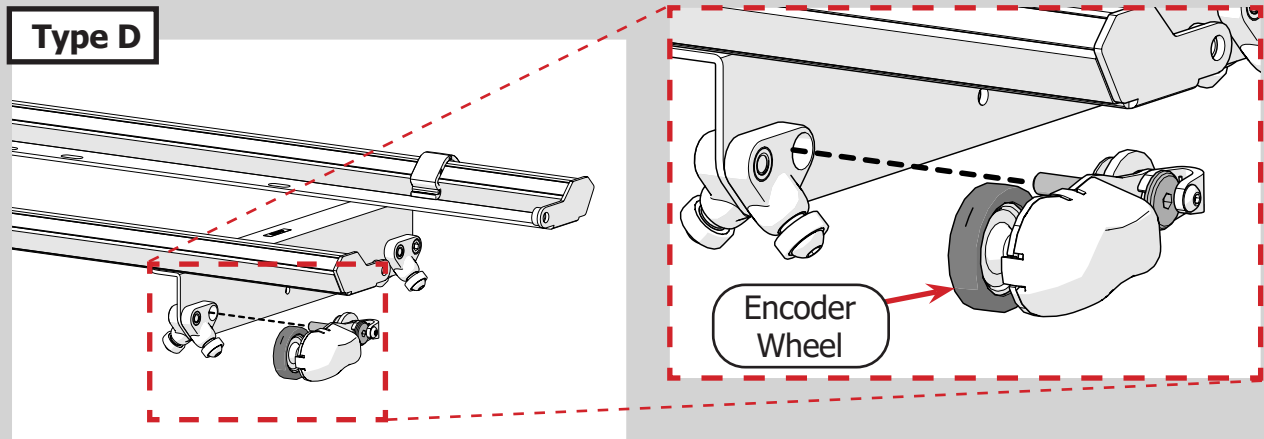

- e) Turn the encoder **lock collar** (shown in blue) to point up. Then tighten the **lock collar screw** with the 2.5 mm Allen wrench.

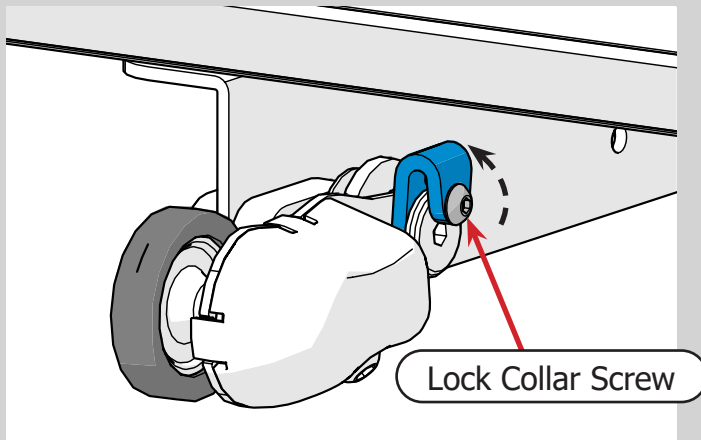

Note: Instructions for plugging the encoder cable into the machine are covered in "Task 7" after the machine has been installed.

Congratulations! You have completed Part One of this manual.

If you are also installing Quilter's Creative Touch (previously called QuiltMotion), complete Part One of your Quilter's Creative Touch manual.

If you are not installing Quilter's Creative Touch at this time, continue to Part Two of this manual on page 11.

Part Two

Before completing the tasks in Part Two of your machine instructions, please complete Part One of your Quilter's Creative Touch (previously called QuiltMotion) instructions if you will be installing automation today.

Progress Checkpoint:

Quilter's Creative Touch Manual Part One (optional)

Have you:

- Installed the motor plate into your bottom carriage?
- Installed the long belt onto your frame?

Task 2 - Installing the Wheels

Parts & Tools Needed:

Back Wheel Base Assembly

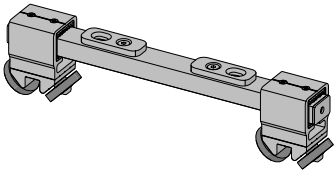

Front Wheel Base Assembly

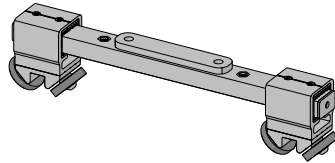

SBHCS Screw
M6 x 25 mm (x2)

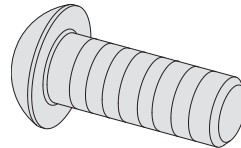

Shoulder Bolt
M6 (x2)

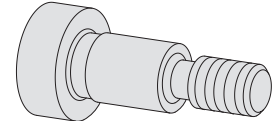

Packaging Level 1
(Leave in packaging)

Packaging Level 1
(Leave in packaging)

Wheel Base
Hardware Box

Wheel Base
Hardware Box

Allen Wrench
4 mm

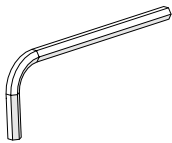

Wheel Base
Hardware Box

Instructions

The machine wheels move the machine across the bottom carriage. To install the machine wheels:

- 1 Lift up the first level of packaging and place it beside the second level. Find the Allen wrench, screws, and bolts needed for this task in **wheel base hardware box**.

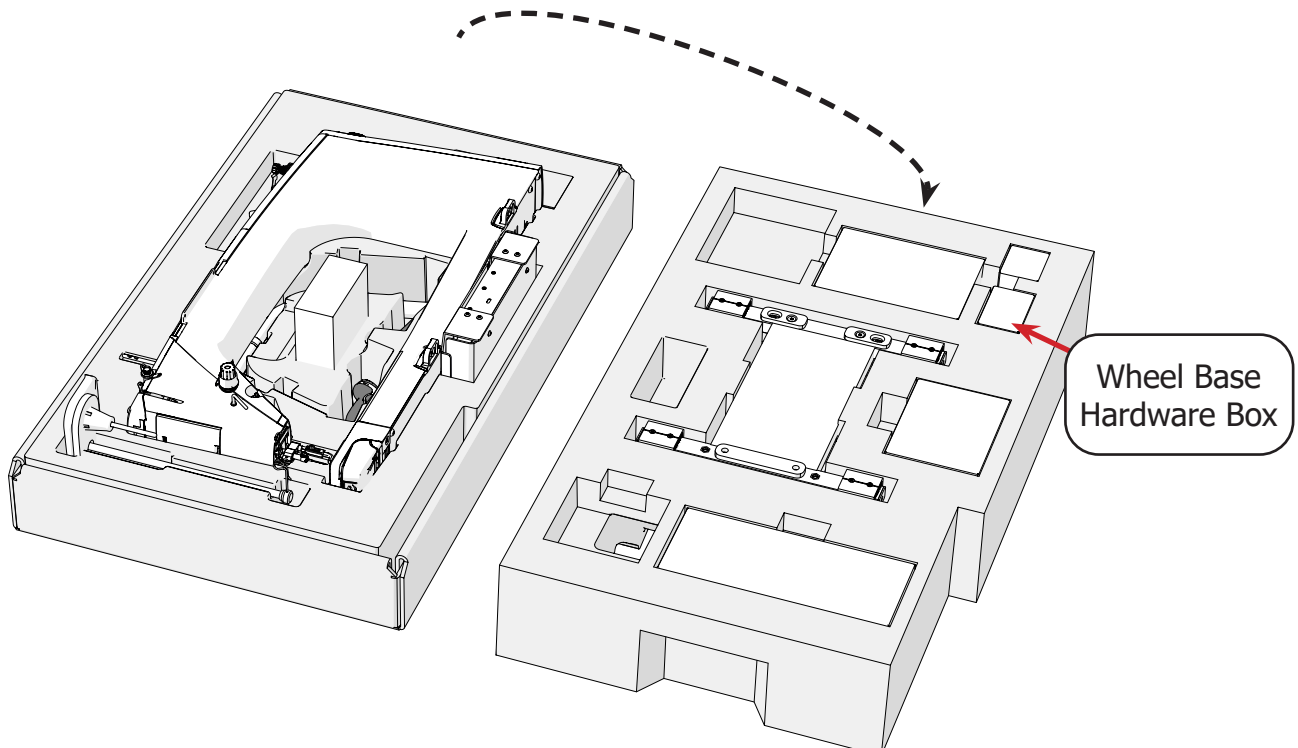

- 2 Remove the center **foam** from the first level of packaging.

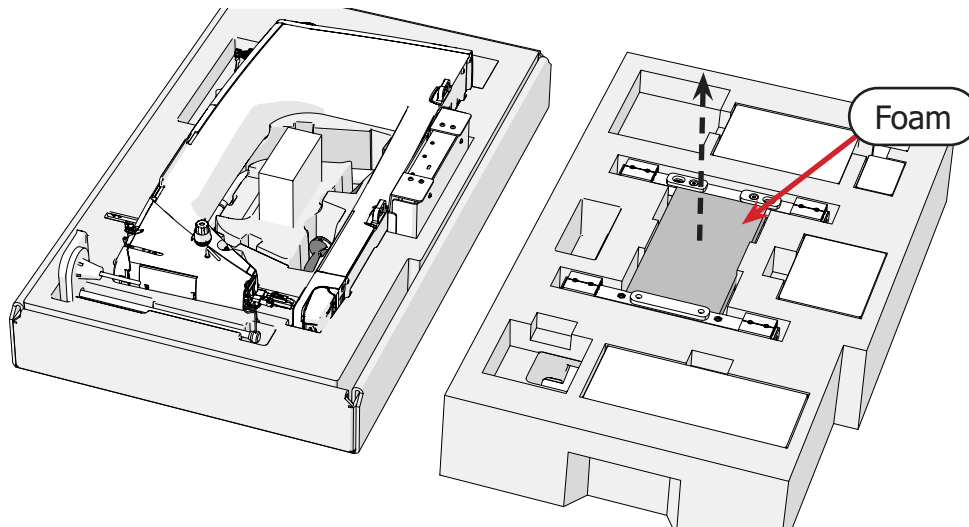

- 3 Take the machine body out of the second level of packaging and place it onto the **wheel base assemblies** in the first layer.

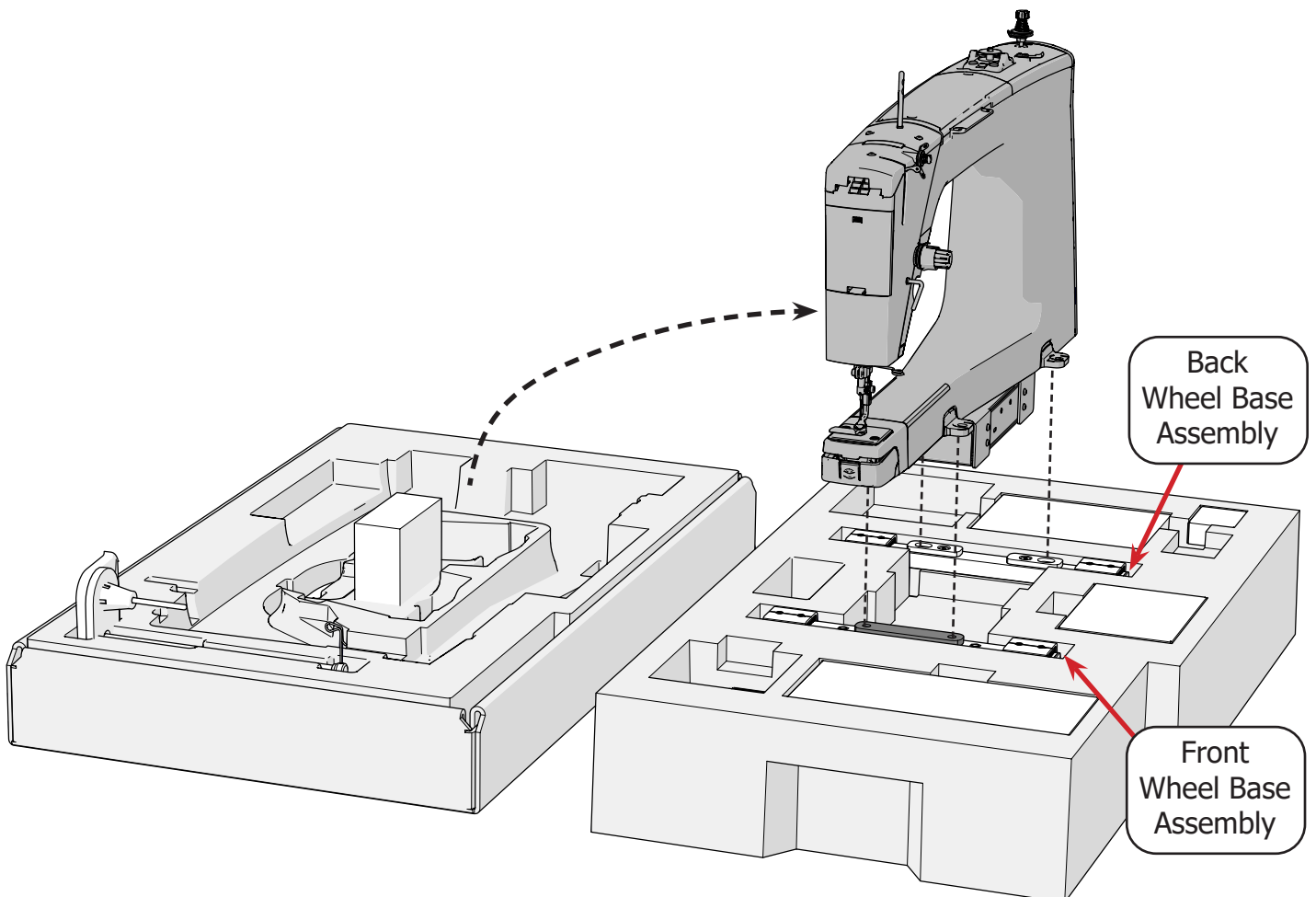

Part Two | Out of Box Assembly

Task 2 - Installing the Wheels (continued)

- 4 Screw the back wheel base assembly in place with two **M6 x 25 mm screws SBHCS** and the L-shaped 4 mm Allen wrench.

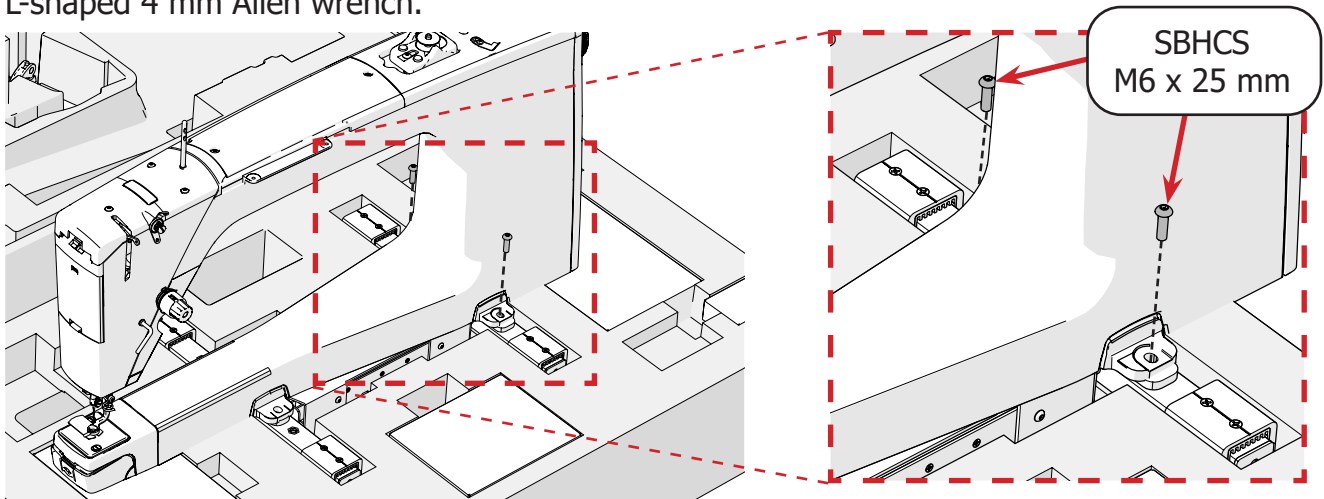

- 5 Use the L-shaped 4 mm Allen wrench to screw in the **M6 shoulder bolts** into the front wheel base assembly.

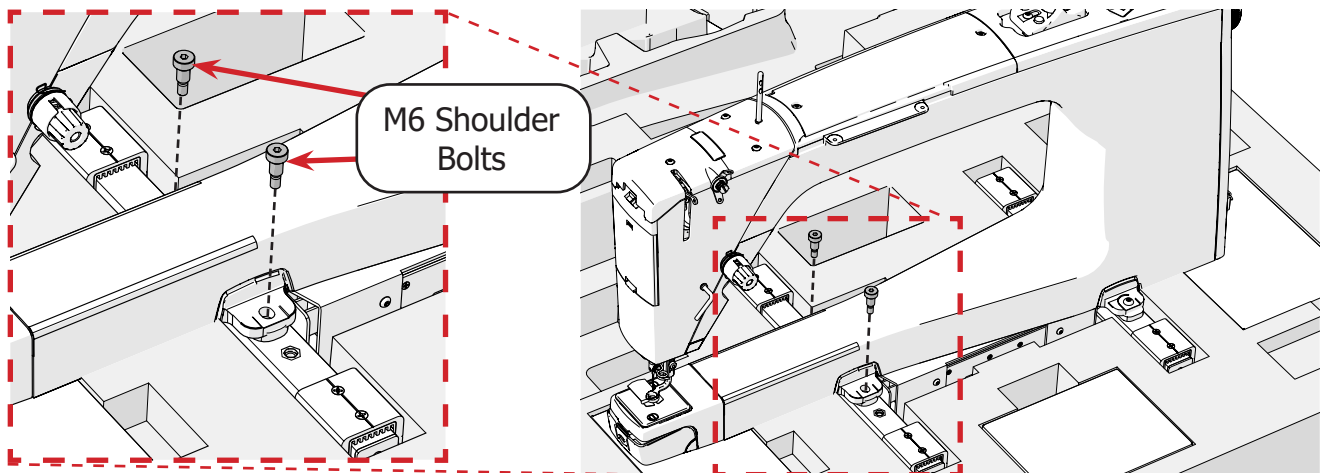

- 6 Now lift the machine out of the packaging. Place the machine onto your frame's bottom carriage, aligning the wheels with the tracks. See your frame's manual for bottom carriage orientation.

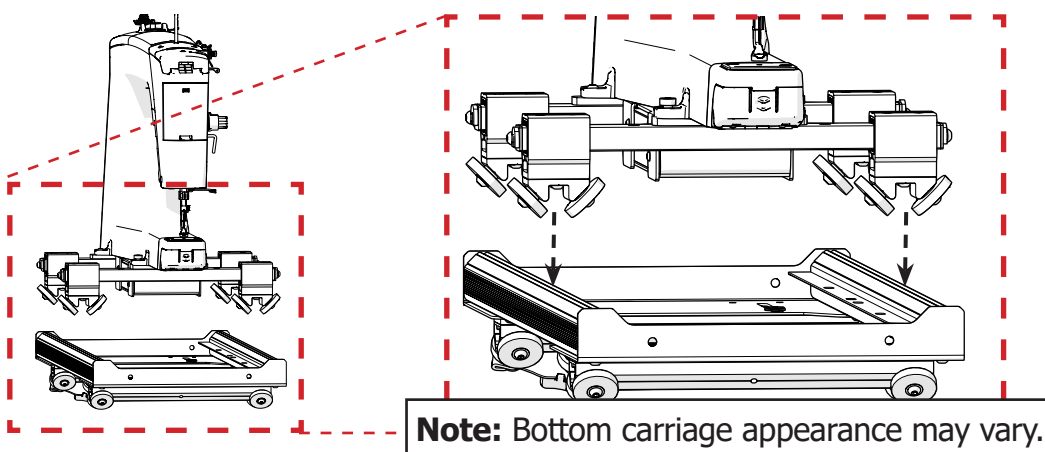

- 7 Loosen two wheel base set screws on one side of the machine (either the right side or left side) with the 4 mm Allen wrench.

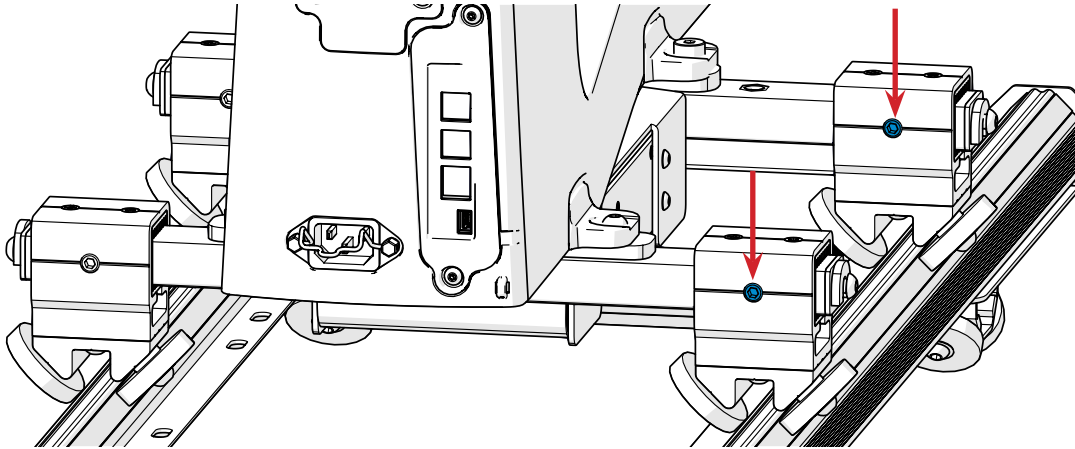

- 8 Slide the machine up and down the bottom carriage tracks.

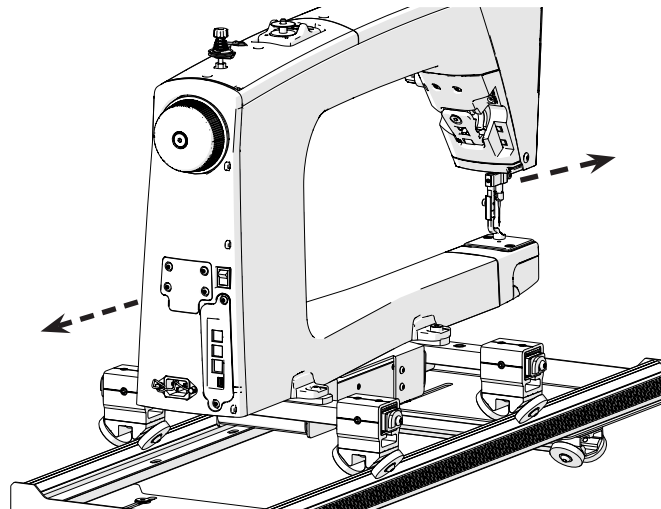

- 9 Check that the machine is centered over the wheels. If needed, shift the machine from side to side.

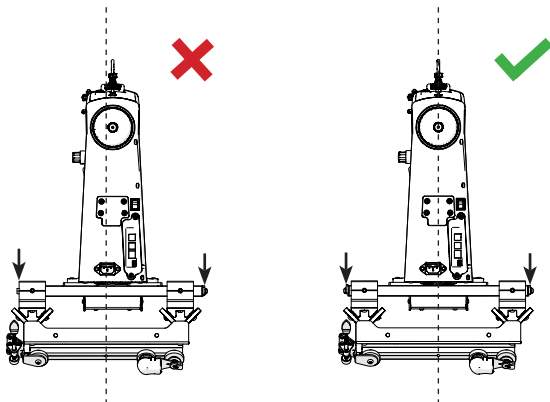

- 10 Re-tighten the wheel block set screws with the 4 mm Allen wrench.

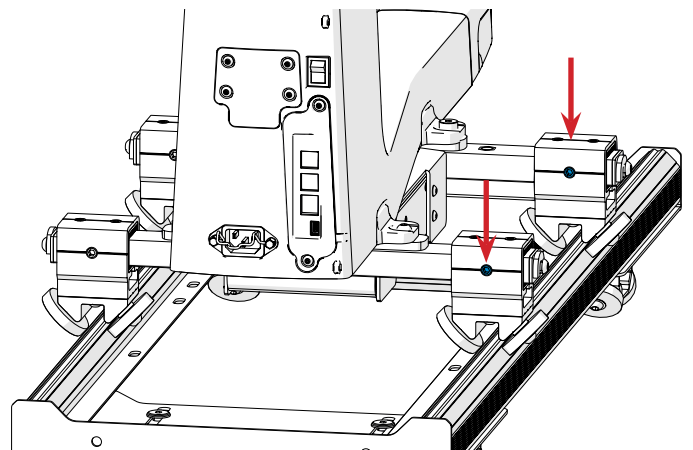

Congratulations! You have completed Part Two of this manual.

If you are also installing Quilter's Creative Touch (previously called QuiltMotion), complete Part Two of your Quilter's Creative Touch manual.

If you are not installing Quilter's Creative Touch at this time but are assembling a new frame, continue to Part Two of your frame manual. If the frame manual is not broken in to parts, follow the manual's directions to:

- Install the channel lock onto the quilting machine.

If you are installing your machine onto a frame that is already fully assembled, continue to Part Three of this manual on page 17.

Part Three

Before completing the tasks in Part Three of your machine instructions, please complete Part Two in your Quilter's Creative Touch (previously called QuiltMotion) manual (if setting up Quilter's Creative Touch at this time), and then part Two of your frame manual.

Progress Checkpoint:

Have you:

- Completed Quilter's Creative Touch Part Two (optional)?

Have you:

- Installed the channel lock onto the quilting machine?

If you've already fully assembled your frame:

- Install the channel lock onto the quilting machine.

Task 3 - Installing the Wheel Covers

Parts & Tools Needed:

Front Left Wheel
Base Cover

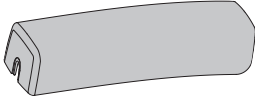

Wheel Base Cover Box

Front Right Wheel
Base Cover

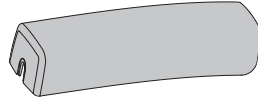

Wheel Base Cover Box

Back Left Wheel
Base Cover

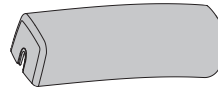

Wheel Base Cover Box

Back Right Wheel
Base Cover

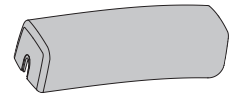

Wheel Base Cover Box

SBHCS Screw
M6 x 16 mm (x4)

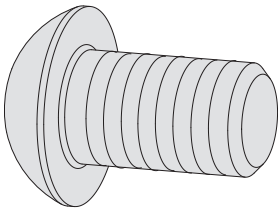

Wheel Base Cover Box

T-handle Allen
Wrench 4 mm

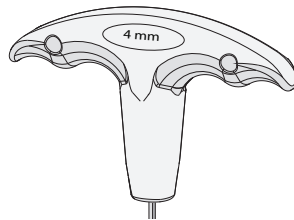

Instructions

Take the following steps to install the wheel base covers onto the machine:

- 1 The parts needed for this task are found in the **wheel base cover box**.

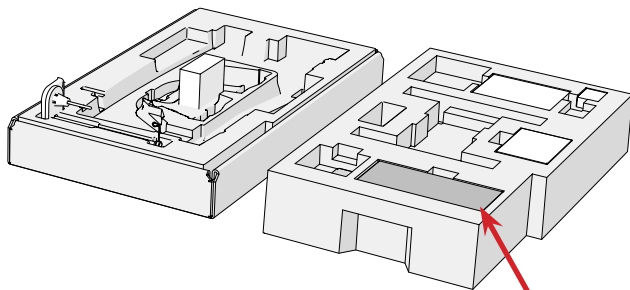

Wheel Base
Cover Box

- 2 Locate the label on the inside of each wheel cover.

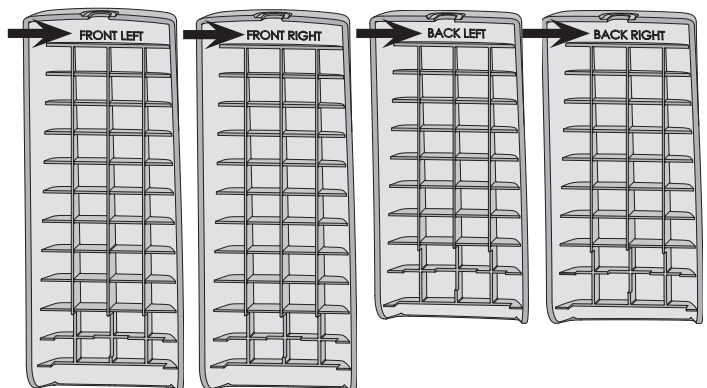

Part Three | Out-of-the-Box Assembly
Task 3 - Installing the Wheel Covers (continued)

- 3 Slide the covers onto the associated leg.

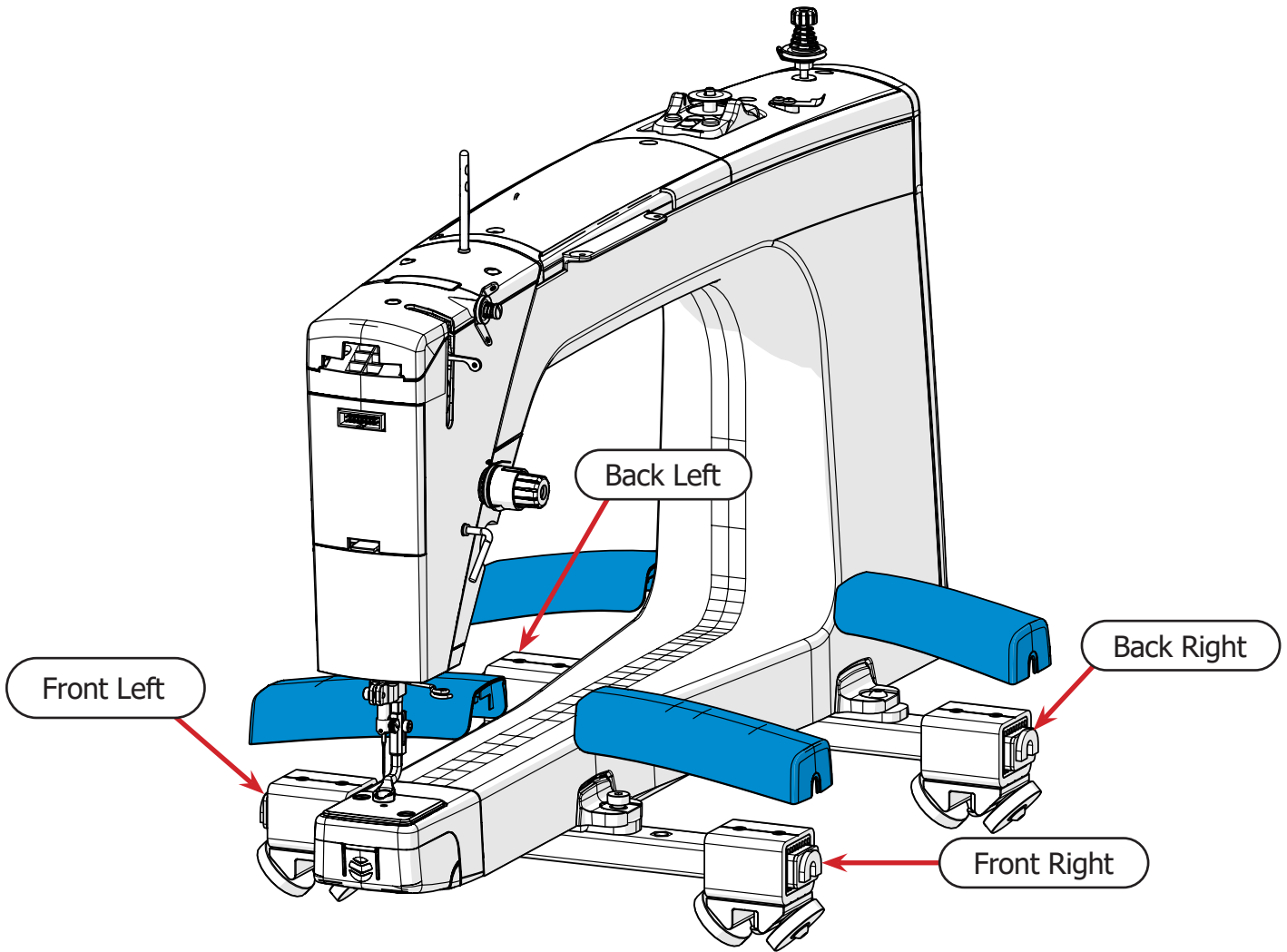

- 4 Screw each cover into place using an **M6 x 16 mm SBHCS screw** and the 4 mm Allen wrench. Tighten until snug.

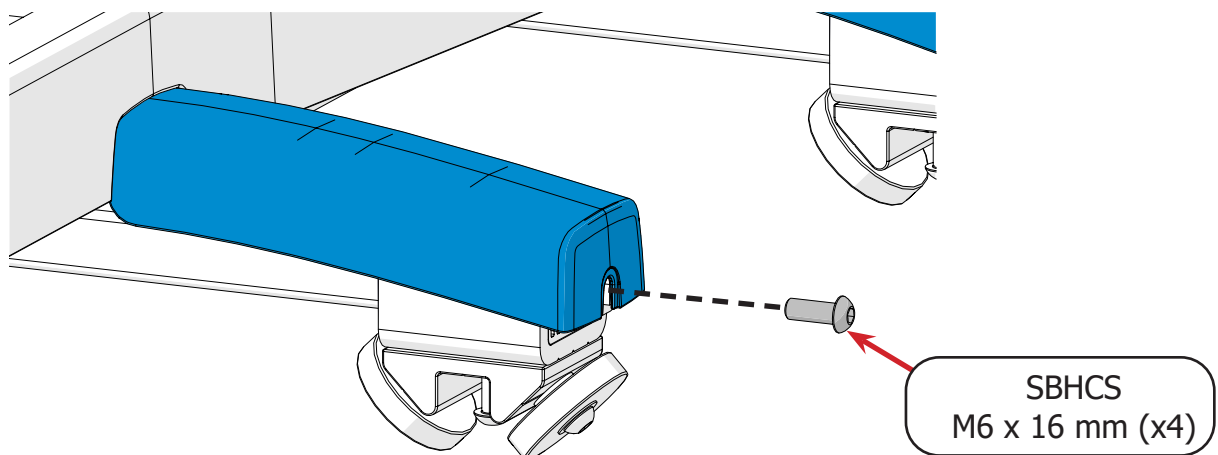

Task 4 - Assembling the Handlebars

Parts & Tools Needed:

Handlebar Assembly

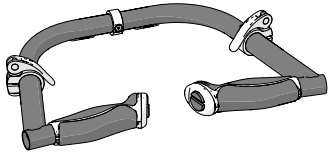

T-handle Allen Wrench 4 mm

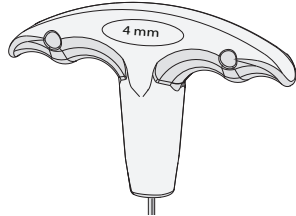

Packaging Level 2

Instructions

Take the following steps to install and adjust the handlebars:

- 1 With the 4 mm T-handle Allen wrench, remove the **handlebar clamp screw** to open the handlebar clamp.

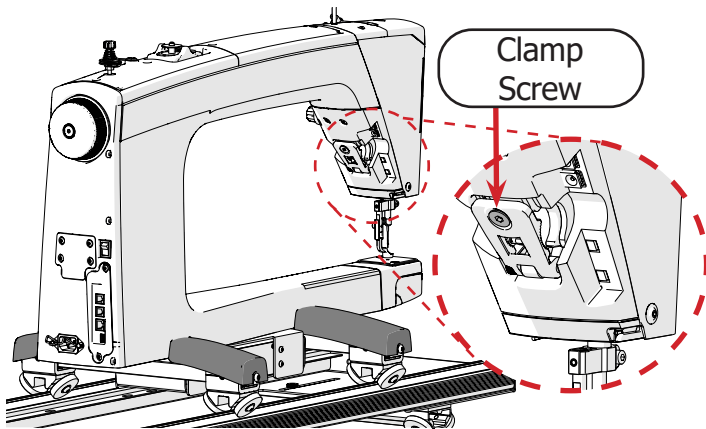

The handlebar clamp opens.

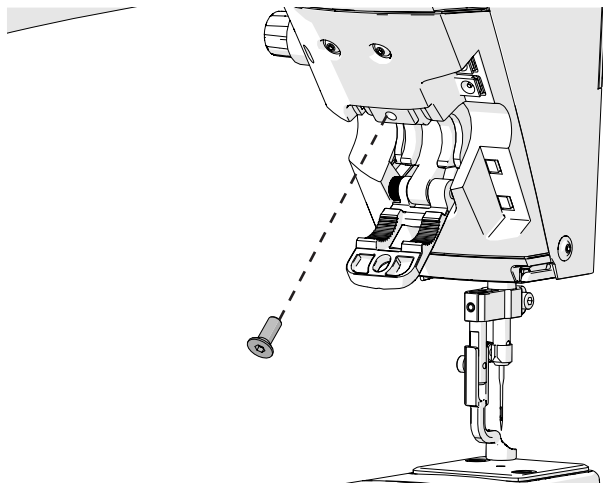

- 2 Take the **handlebar assembly** from the second level of the packaging.

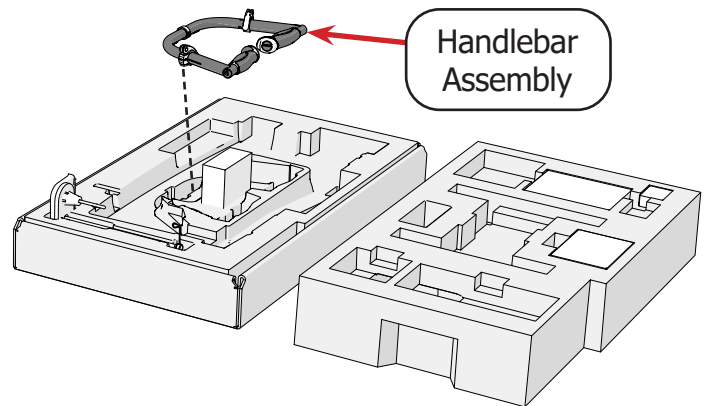

- 3 Slide them into the slot so that the **cables** are on the bottom.

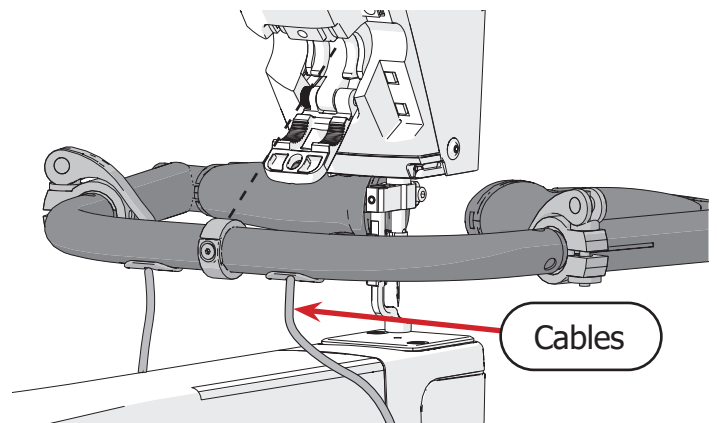

- 4 Close and hold the clamp, and loosely screw in the **clamp screw** just enough to keep the clamp from opening.

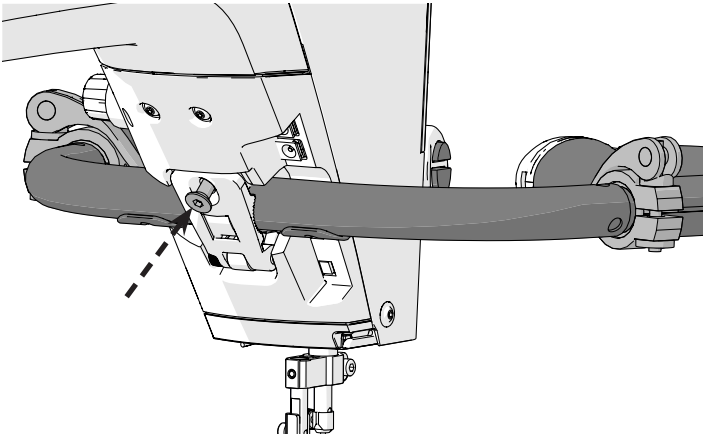

- 5 Hold the handlebars at the desired angle and tighten the **clamp screw**.

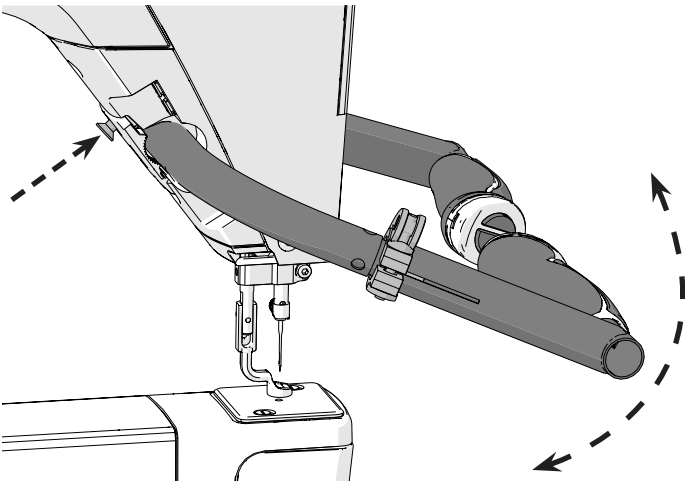

- 6 Open the **handlebar levers** (shown in blue).

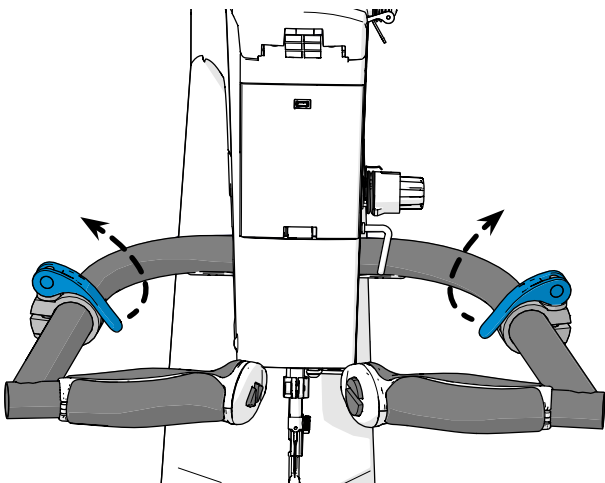

- 7 Twist the controls vertically until they are comfortable to hold and operate.

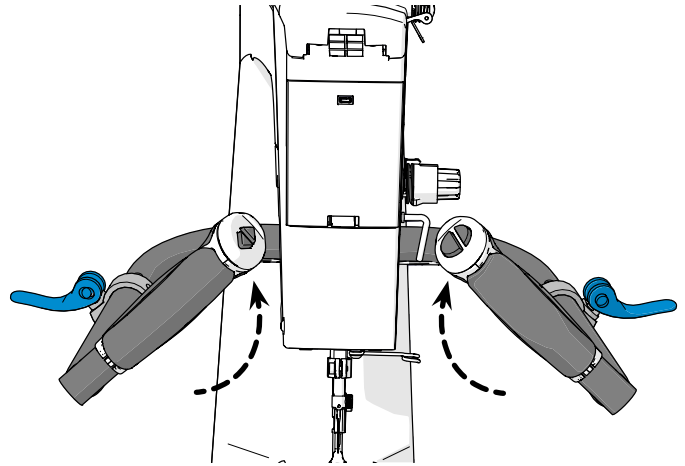

- 8 If desired, extend the handles outward to improve the reach of the machine.

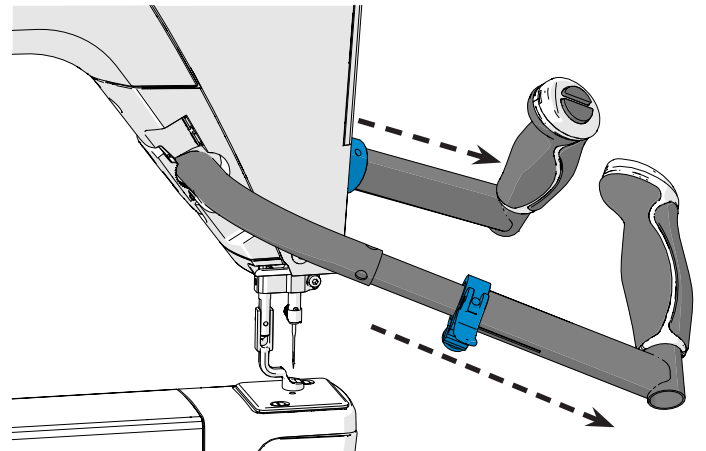

- 9 Once you are comfortable with the position of the handles, close the **handlebar levers**.

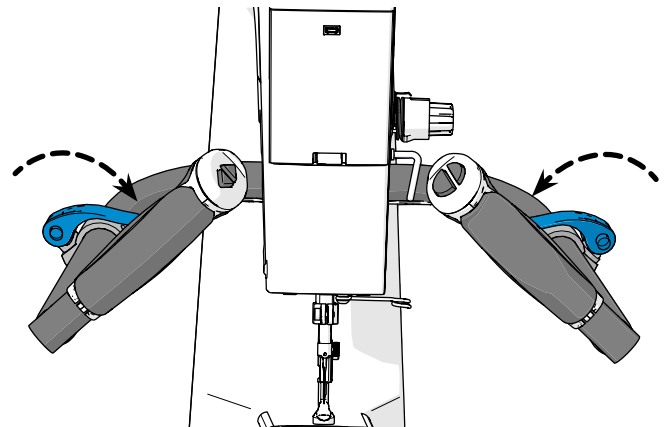

Part Three | Out-of-the-Box Assembly

Task 4 - Assembling the Handlebars (continued)

Tip: For micro-stippling, angle the handlebars down toward the fabric in step 5, and leave the controls horizontal in step 6.

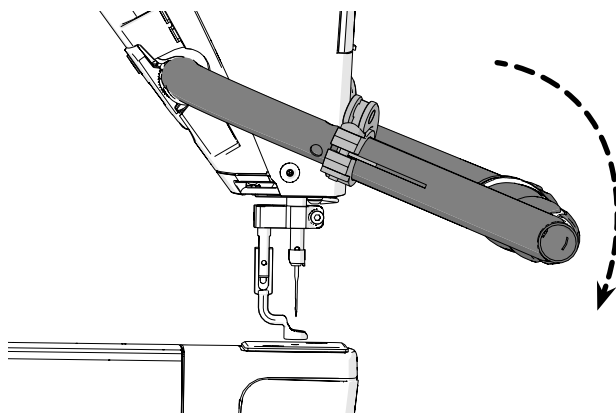

- 10 Plug the color-coded cables from the handlebars into the machine.

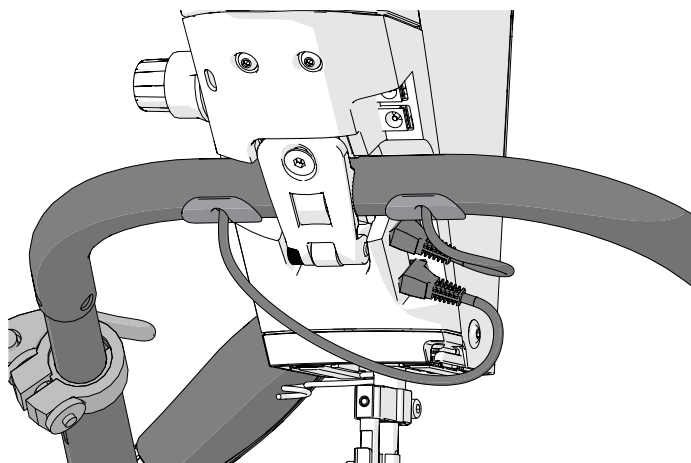

Task 5 - Connecting the Display

Parts & Tools Needed:

7 Inch Touch Display

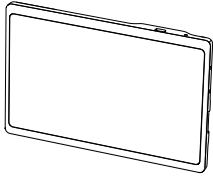

Display Box

SBHCS
M5 x 16 mm (x2)

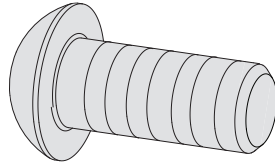

Display Box

T-handle Allen
Wrench 3 mm

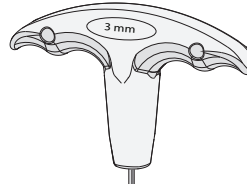

Tools Box

T-handle Allen
Wrench 2.5 mm

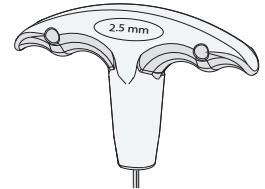

Instructions

Take the following steps to install the display:

- 1 The parts needed for this step are in the **display box**.

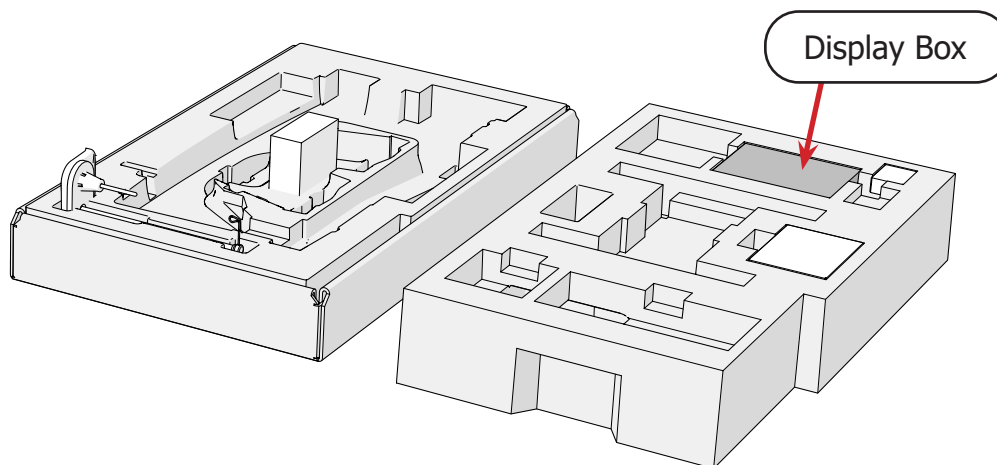

- 2 Use the 2.5 mm Allen wrench to remove the M4 x 6 mm SBHCS and **front display cover** from the machine.

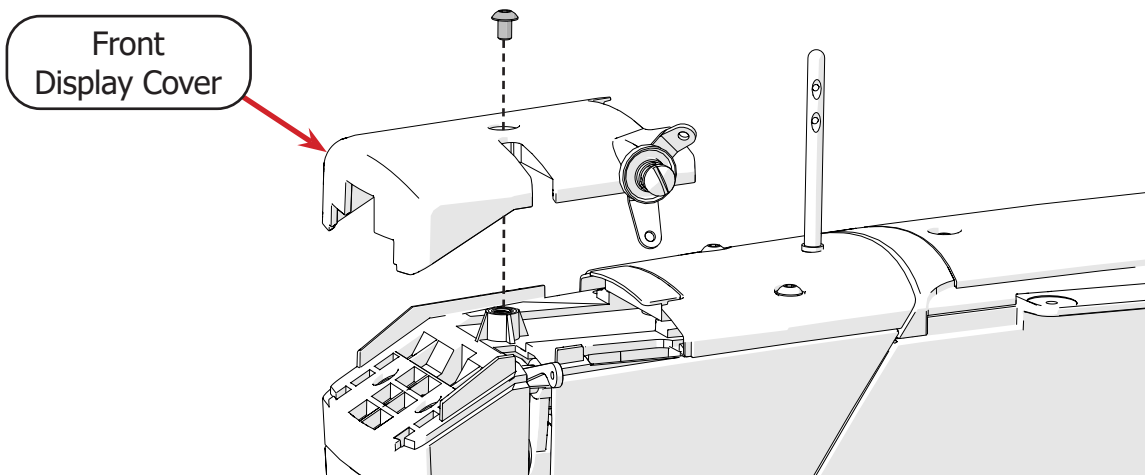

Part Three | Out-of-the-Box Assembly

Task 5 - Connecting the Display (continued)

- 3 Attach the **7 inch touch display** with two **M5 x 16 mm SBHCS** and the 3 mm Allen wrench.

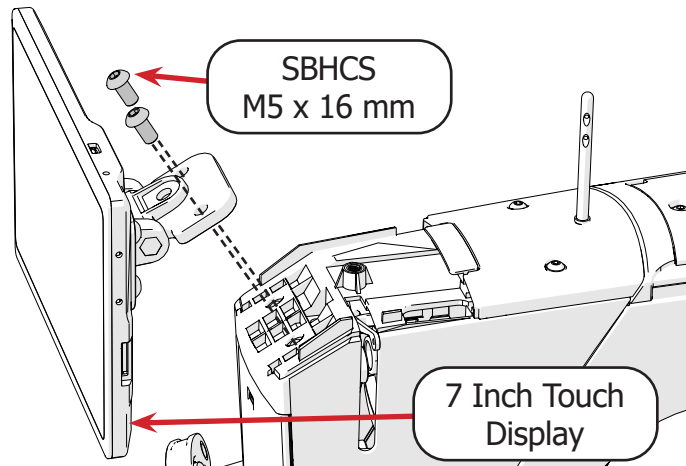

- 4 Re-attach the plastic cover with the 2.5 mm Allen wrench.

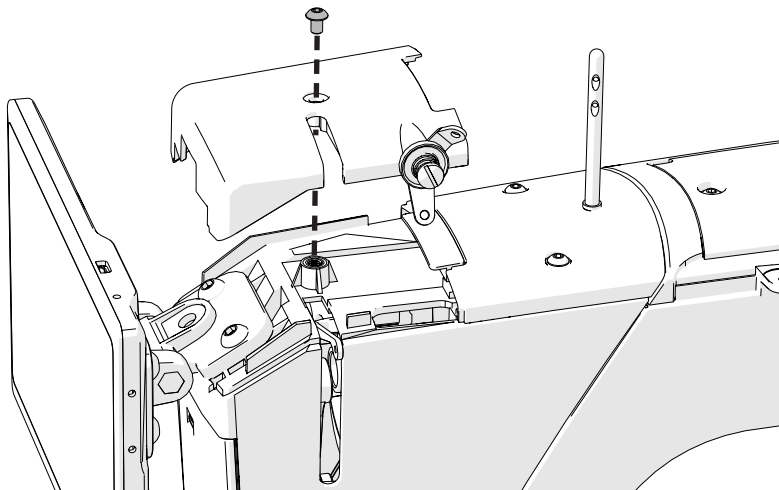

- 5 Plug the display into the port behind it, and press the cable into the cable clip to secure it.

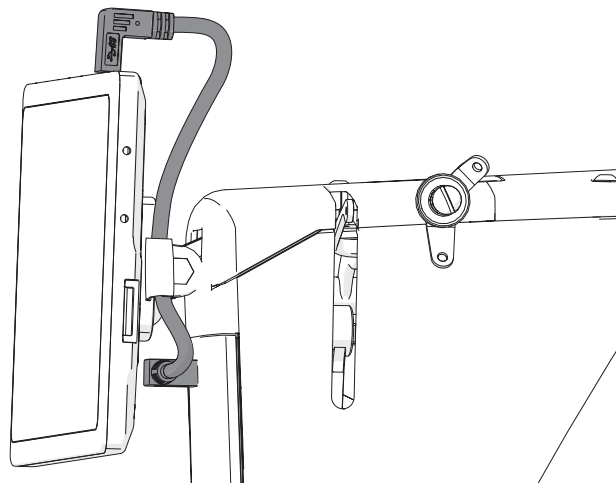

Task 6 - Attaching the Thread Stand

Parts & Tools Needed:

Thread Stand
Assembly

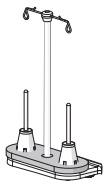

Packaging Level 2

SBHCS Screw
M4 x 8 mm (x2)

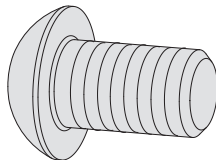

Thread Stand
Hardware Box

T-handle Allen
Wrench 2.5 mm

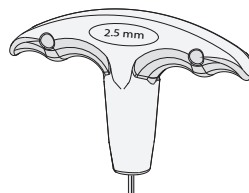

Instructions

Take the following steps to install the thread stand assembly:

- 1 Take the **thread stand assembly** out of the second level of packaging. The screws needed for this task are in the **thread stand hardware box**.

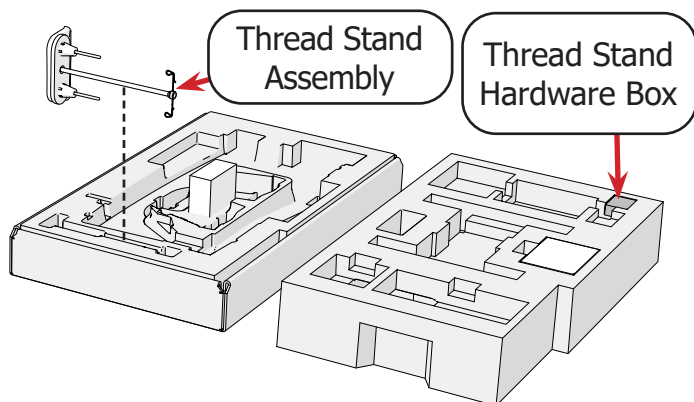

- 2 Slide the thread stand assembly over the screw holes on the small lip on the right side of the machine.

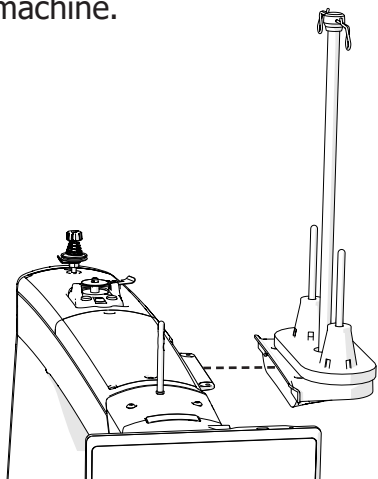

- 3 Use the 2.5 mm Allen wrench and two **SBHCS M4 x 8 mm screws** to fasten the thread stand in place.

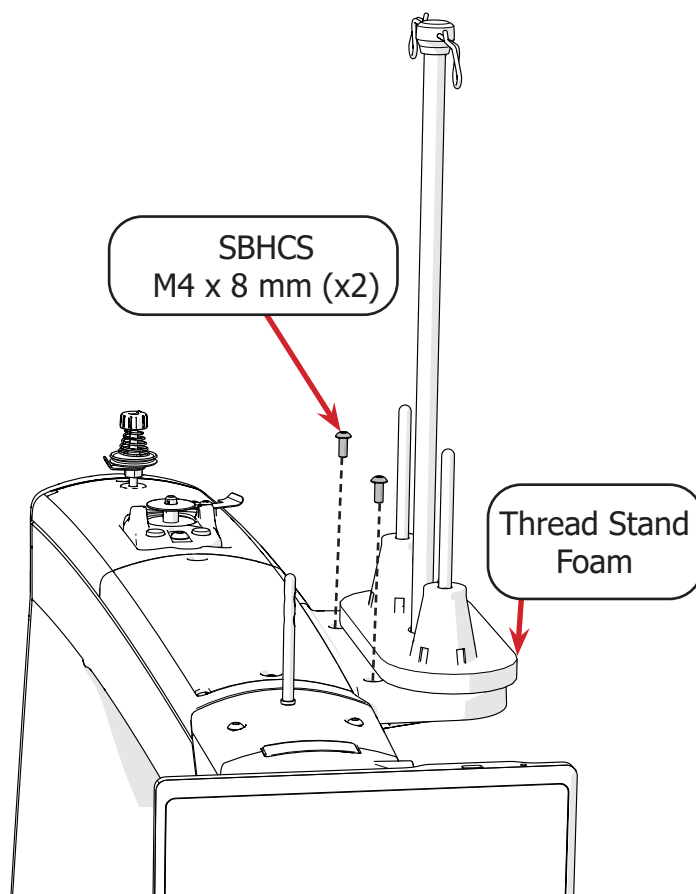

Note: If necessary, push back the **foam** on the thread stand to expose the screw holes.

Task 7 - Installing the Upper Encoder

Parts & Tools Needed:

Upper Encoder
(silver spring)

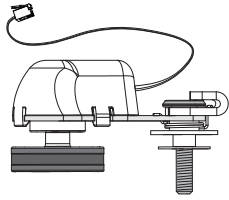

Encoder Box

T-handle Allen
Wrench 4 mm

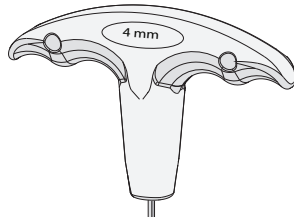

T-handle Allen
Wrench 2.5 mm

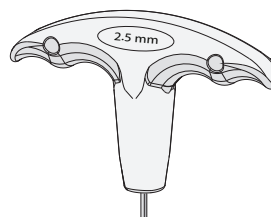

Instructions

The encoders monitor the position of the machine over the frame, allowing for regulated stitching. The upper encoder is installed on the outer left-rear wheel of the machine. Take the following steps:

- 1 Use the 4 mm Allen wrench to remove the outer **left rear wheel** from the machine.

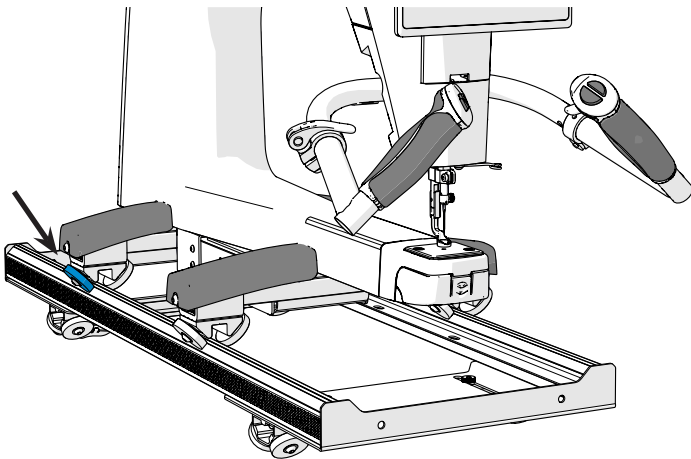

The **wheel screw** will not be needed again, and can be stored with the packaging materials.

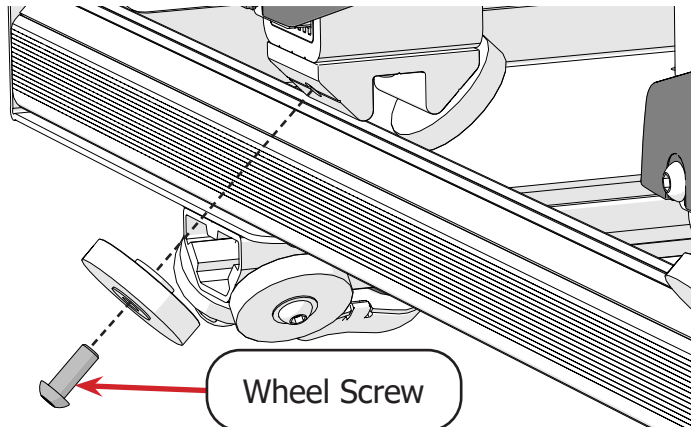

- 2 Find the **upper encoder** in the **encoder box**. The upper encoder has a silver spring and a purple sticker on the cable.

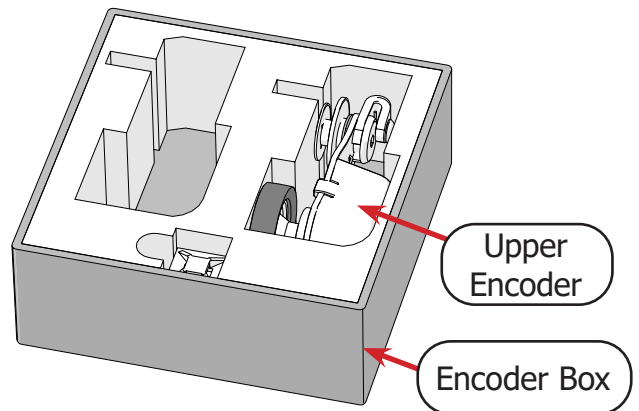

- 3 Loosen the **lock collar screw** on the upper encoder with the 2.5 mm Allen wrench until the **lock collar** (shown in blue) turns freely.

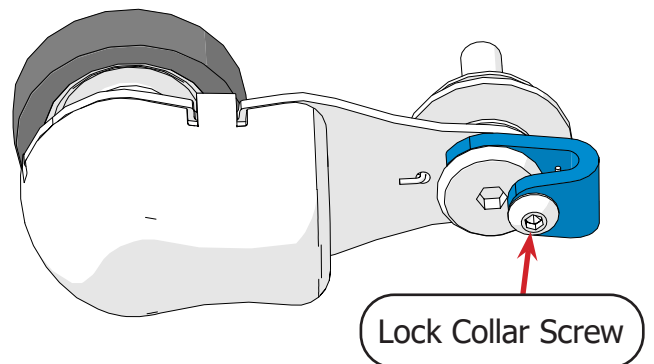

- 4 Slide the wheel onto the upper **encoder bolt** so that the **wheel hub** faces away from the encoder.

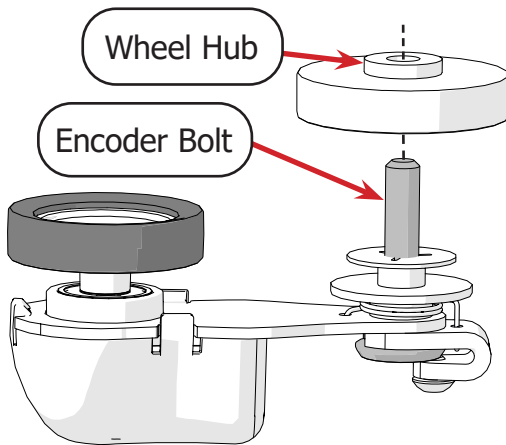

- 5 Place the encoder bolt into the left rear wheel hole so the **encoder wheel** is between the two left machine wheels.

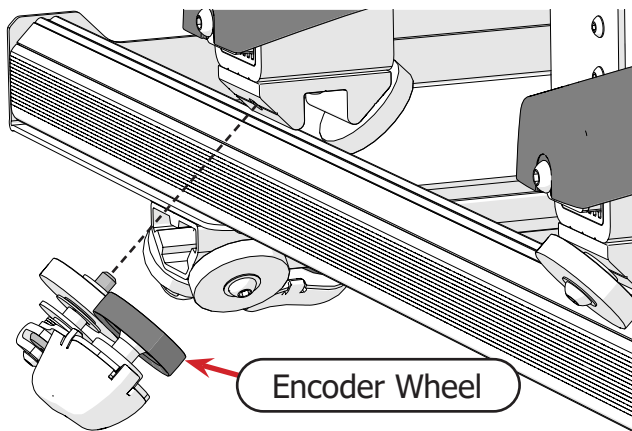

- 6 Tighten the **encoder bolt** with the 4 mm Allen wrench.

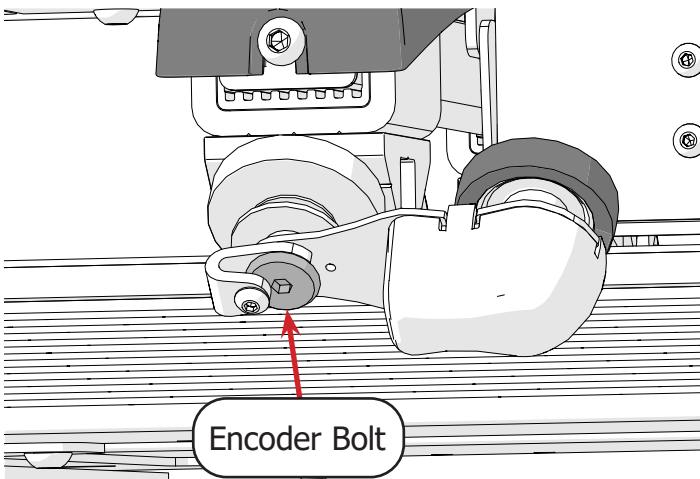

- 7 Turn the encoder lock collar to the 12 o'clock position and tighten the **lock collar screw** with the 2.5 mm Allen wrench.

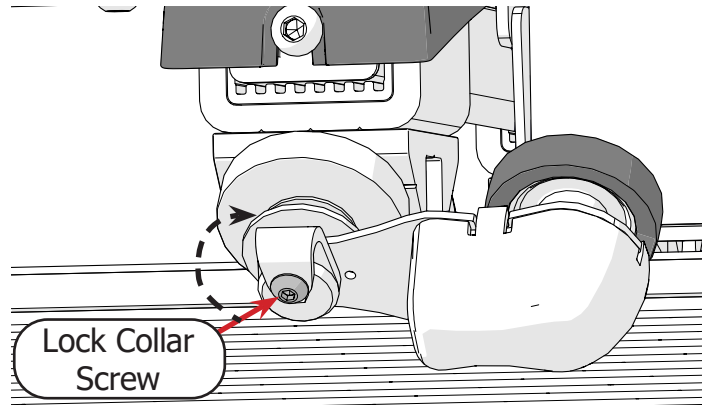

- 8 Plug the encoder cables into the **encoder ports** of the matching sticker color.

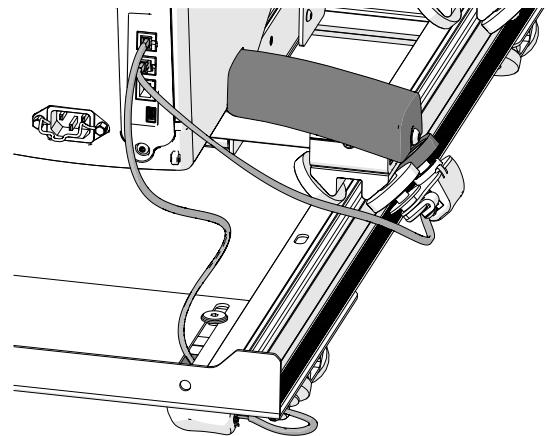

Task 8 - Turning the Machine On/Off

Parts & Tools Needed:

Power Cord

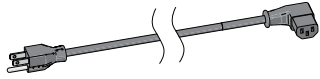

Power Cord/Oil Bottle
Box

Instructions

The **power cable port** and **power switch** are located on the back of the machine. To power on the machine, take the following steps:

- 1 Find the power cord in **power cord/oil bottle box**.

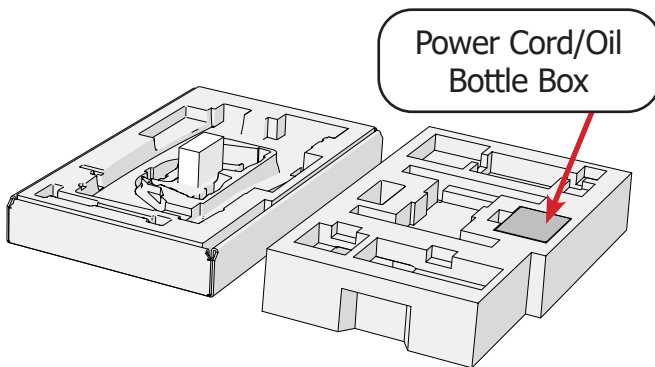

- 2 Lift up the **power cable retainer** (blue) and plug the **power cord** into the back of the machine.

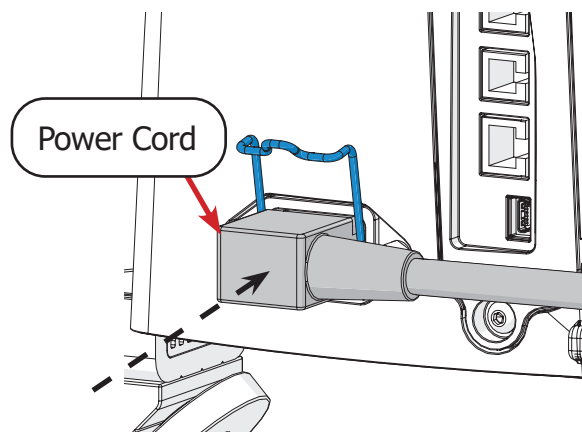

- 3 Press the **power cable retainer** down firmly until it grasps the power cable.

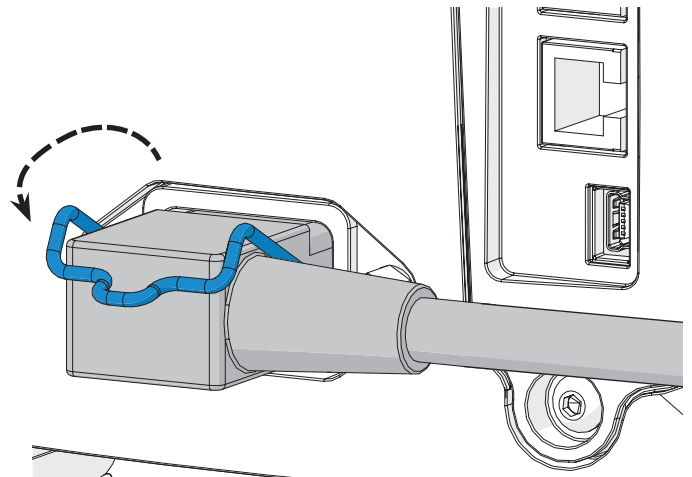

- 4 Press the **power switch** up to turn the machine on.

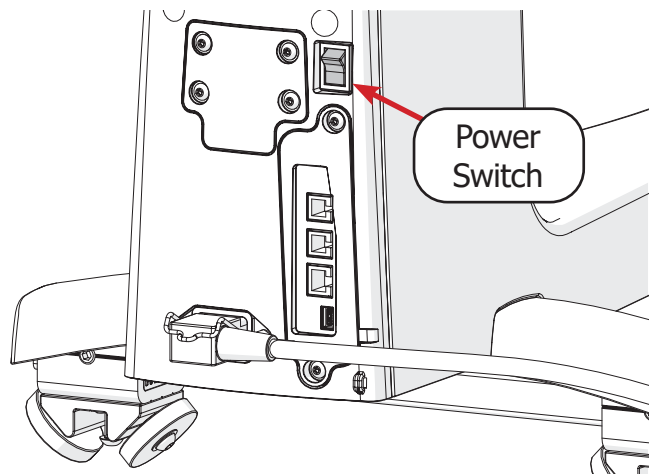

Preparing to Quilt

This section of the manual covers the steps needed to get ready to quilt.

Help Guides	page 30
Task 9 - Winding a Bobbin	page 31
Task 10 - Loading the Bobbin Case	page 34
Task 11 - Threading the Machine	page 37

Help Guides

For quick assistance while you're quilting, check out the **Help Guides** on your machine. To reach the help guides, take the following steps:

- 1 Press the **menu** icon in the top right corner of the screen and select **Help**.

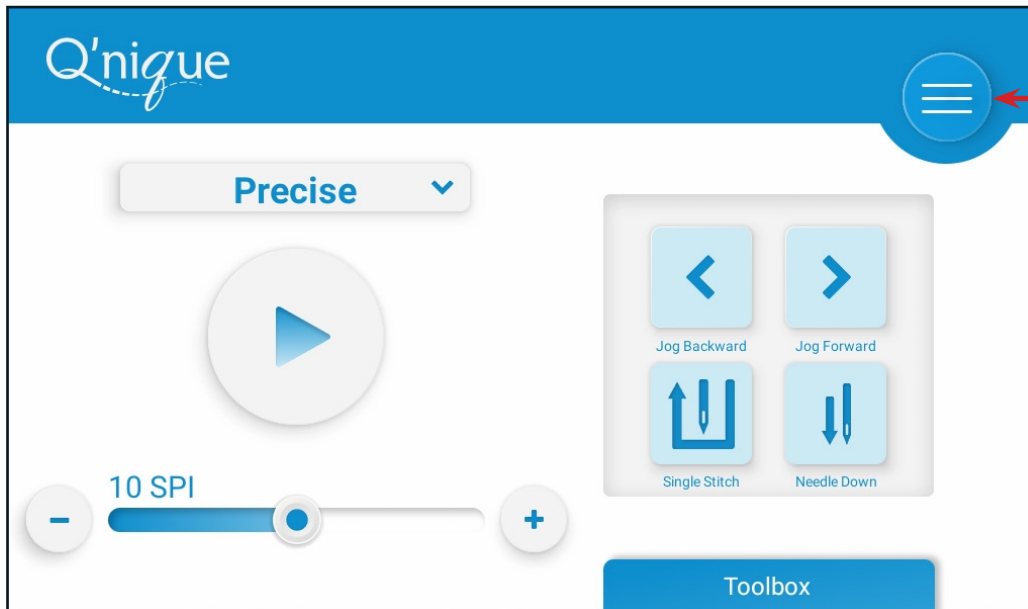

The Help Guide menu opens.

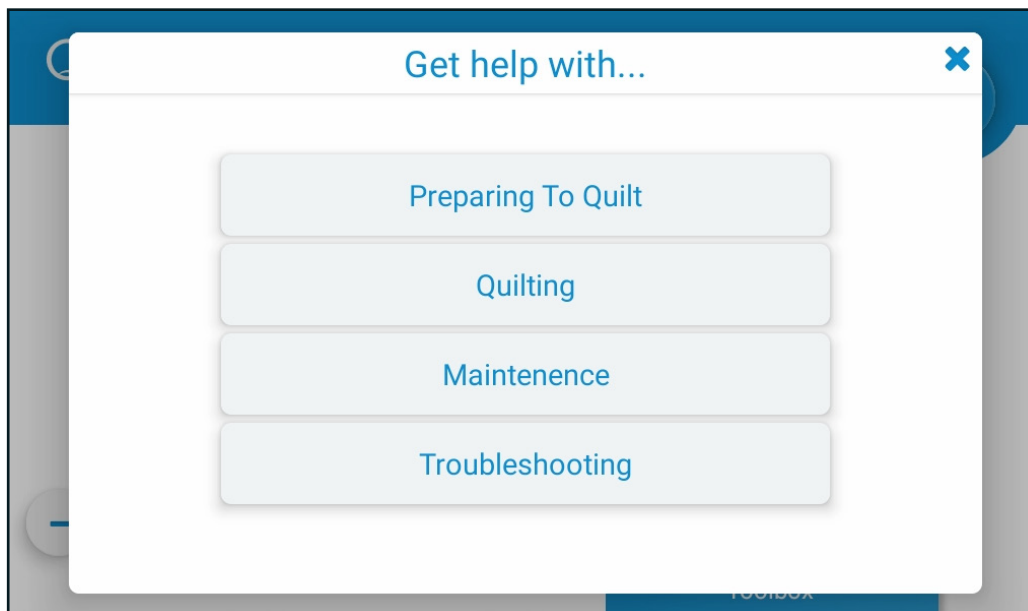

- 2 Select the item that you need help with from the menu.

Task 9 - Winding a Bobbin

Parts & Tools Needed:

Bobbin
(Class M Large)

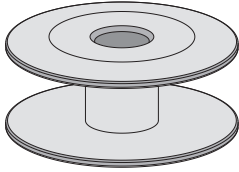

Tools Box

T-handle Allen Wrench
3 mm (optional)

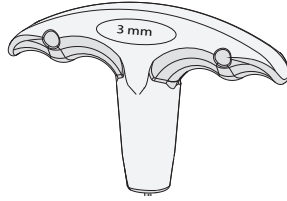

Winding Instructions

Your machine comes with two bobbins pre-wound with 50 weight polyester Finesse thread. An empty M-class bobbin has also been provided. It's important to choose bobbin thread that is similar in type and quality as the top thread. For more information on choosing thread, see "Choosing Your Thread" on page 103.

Note: This machine uses cone-style thread. Unless you have the spool accessory, please use only thread cones for this machine.

The following diagram outlines the path the thread (shown in blue) must take to wind the bobbin.

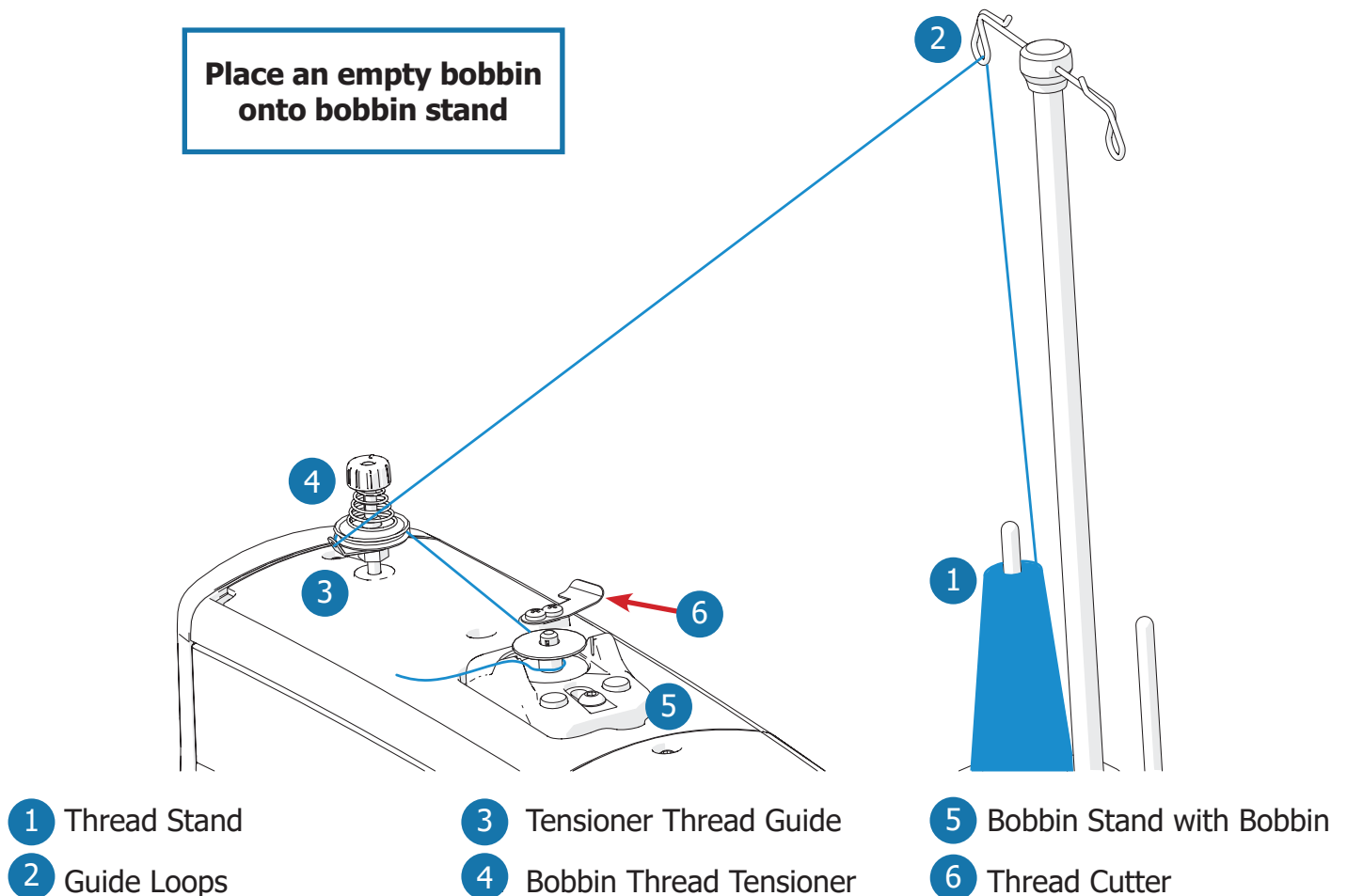

Part Three | Preparing to Quilt

Task 9 - Winding a Bobbin (continued)

- 1 Run the thread through the **thread mast guide loop** directly above the thread cone.

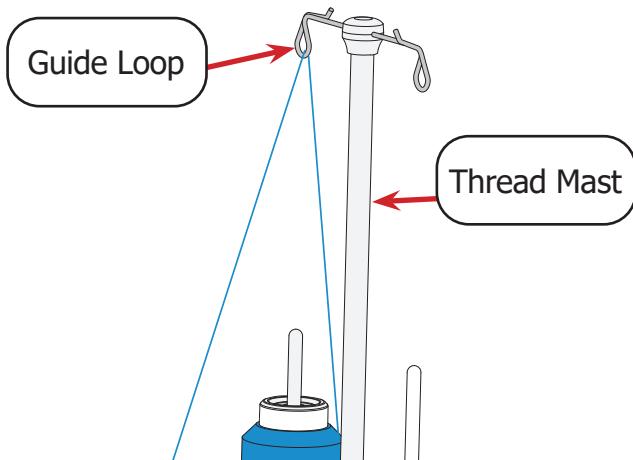

- 2 Feed the thread through the back of the **thread guide**, then wrap it around the back of the tensioner, between the discs.

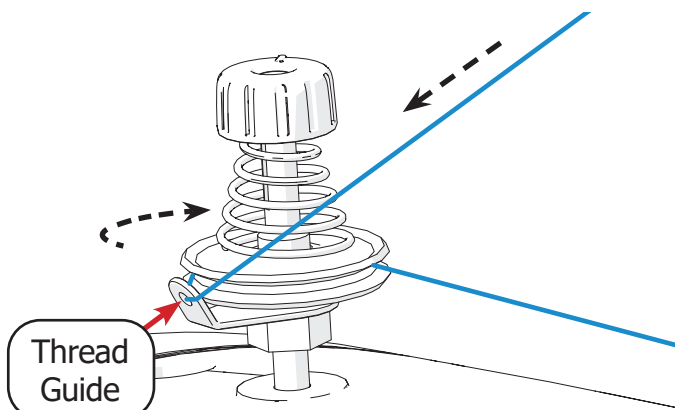

- 3 Wrap the thread clockwise around the empty bobbin. Press **start** when ready.

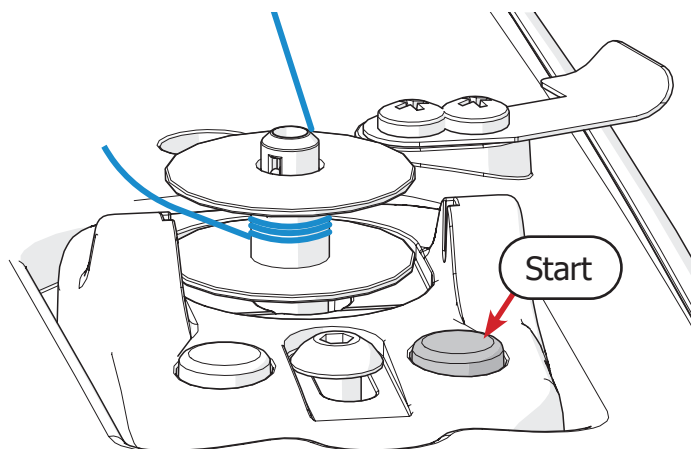

- 4 Winding stops automatically when the bobbin is full. Cut the bobbin away from the thread cone using the **thread cutter** near the bobbin winder.

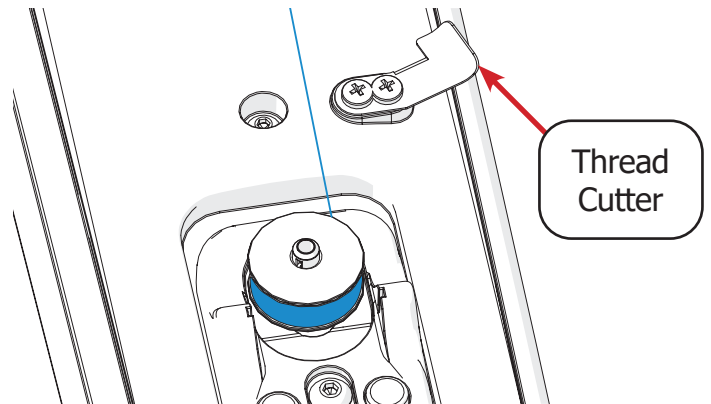

- 5 The bobbin thread should be neat and smooth, and not mounded to one side.

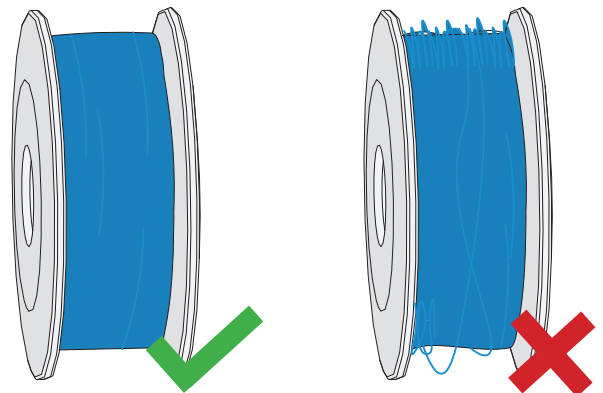

To troubleshoot bobbin winding issues, see page 88.

Note: To stop the winding process manually, press **stop**.

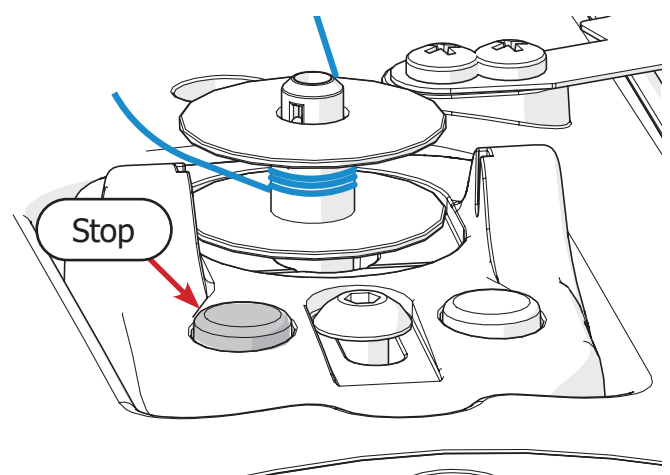

Adjust Fill Levels

The bobbin winder can be adjusted to fill a bobbin to different levels if desired.

- 1 To adjust the bobbin winder, loosen the **M5 x 16 mm SBHCS** with the 3 mm Allen wrench.

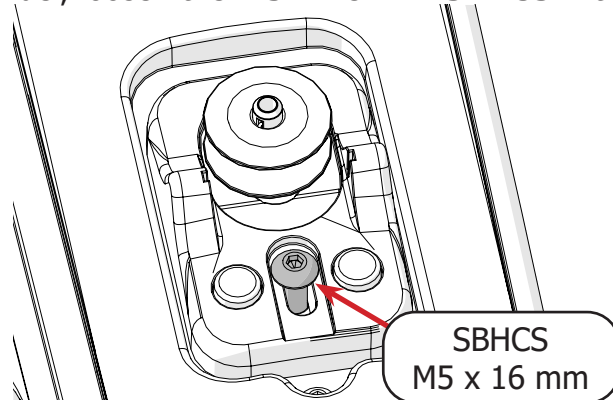

- 2 Slide the bobbin winder until the **guide line** underneath the bobbin is positioned where you want the bobbin thread to finish filling.

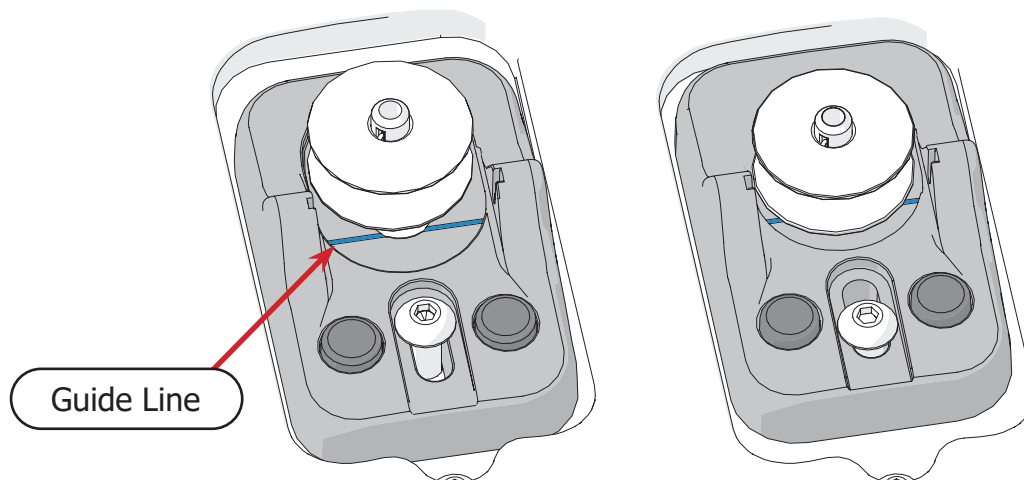

- 3 Tighten the M5 x 16 mm SBHCS to secure the bobbin winder in place.

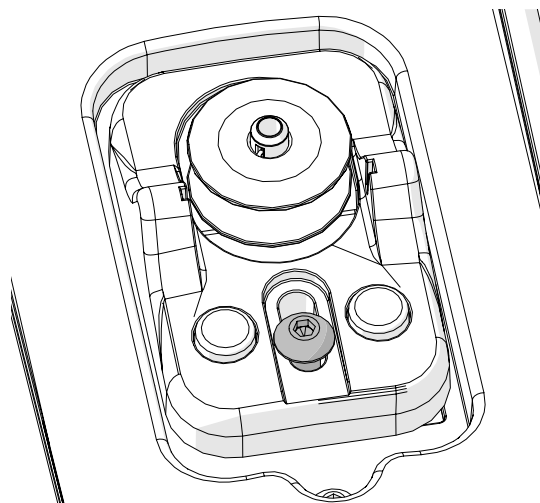

Task 10 - Loading the Bobbin Case

Take the following steps to insert the wound bobbin into the bobbin case and place it in the machine:

- 1 Check that the needle is up. If needed, rotate the **hand wheel** or press the "Needle Up/Down" on the display to raise the needle.

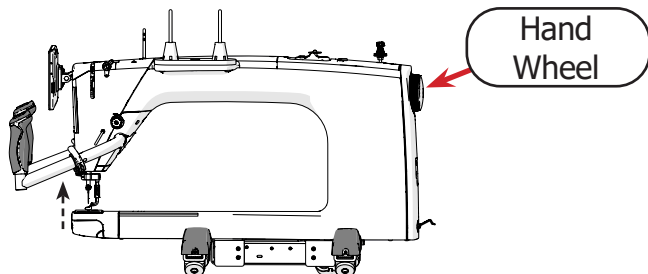

- 2 For your safety, press the **Menu** icon on the display to go to the Settings menu; this prevents the machine from stitching.

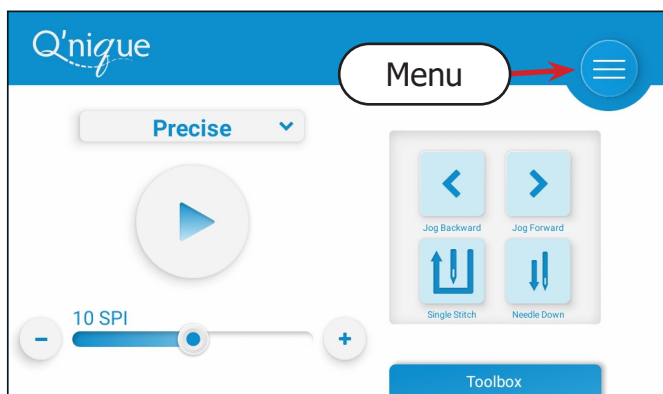

- 3 Push in and down on the **hook assembly cover** (shown in blue) to open it.

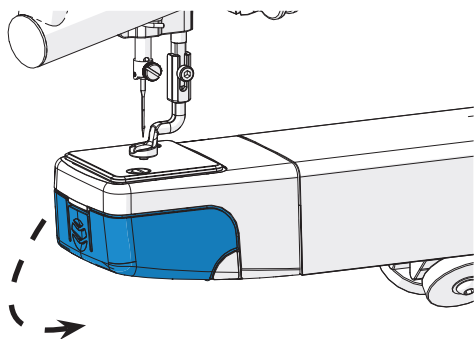

- 4 Pull on the bobbin case **release lever** (shown in blue) to remove the bobbin case from the hook assembly.

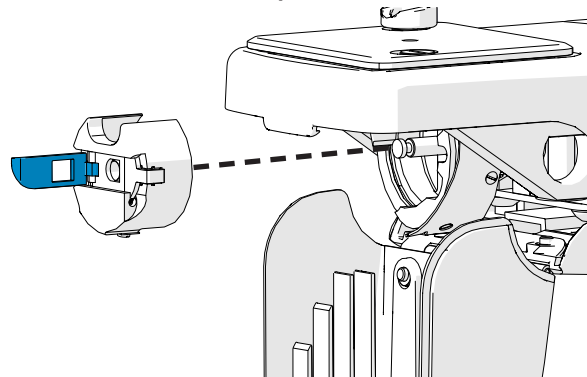

- 5 Place the wound bobbin into the **bobbin case**. Note the direction that the thread is coming off the bobbin in relation to the case.

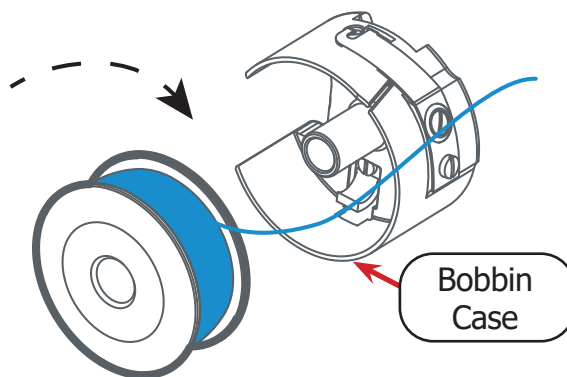

- 6 Slip a few inches of thread through the **slot** and out of the **hole**.

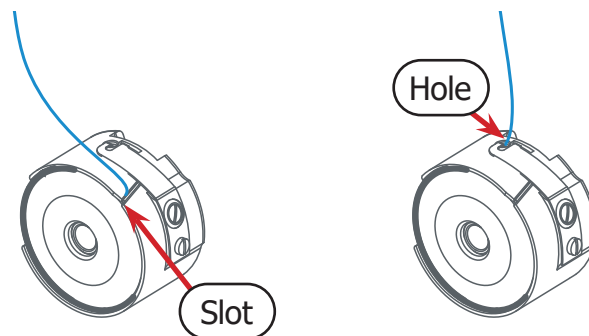

Note: If the bobbin is installed correctly, it turns clockwise when the thread is pulled.

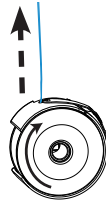

7 Test the tension of the bobbin case every time bobbin thread is changed; bobbin tension is the foundation for correct thread tension.

a. Place the bobbin case on its side, on your palm.

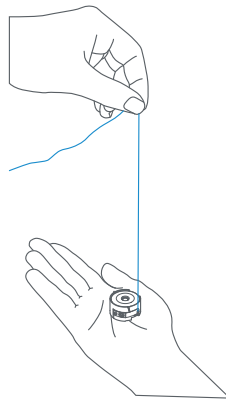

b. Pull up on the thread. The thread should run freely and the bobbin should rise into a vertical position without lifting off your hand.

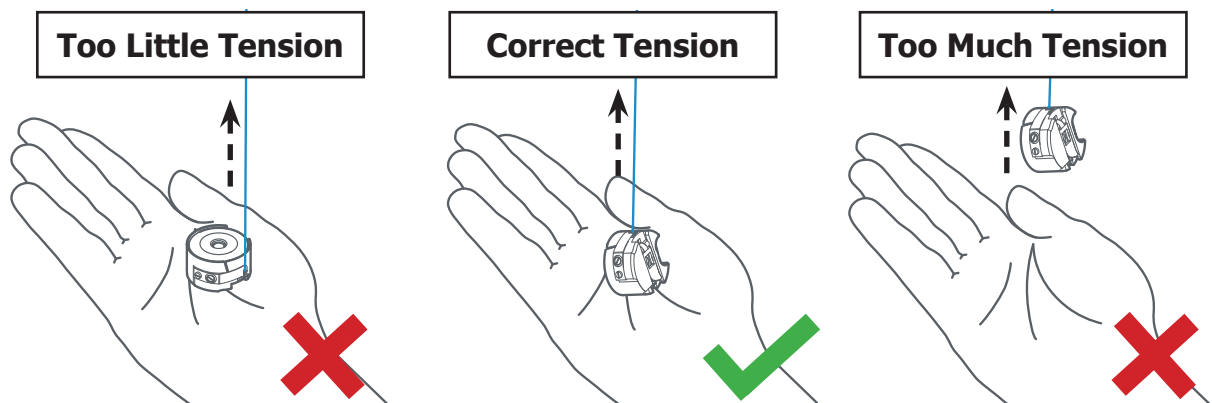

- If the bobbin case remains on its side, there is too little tension. Turn the **large screw** (shown below in blue) clockwise.
- If the case lifts into the air, there is too much tension. Turn the **large screw** (shown below in blue) counter-clockwise.

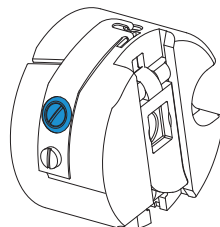

Task 10 - Loading the Bobbin Case (continued)

- 8 Place the bobbin case inside the quilting machine with the **release lever** (shown in blue) at the 3 o'clock position. It should click into place. Do not pull on the lever while inserting the bobbin case.

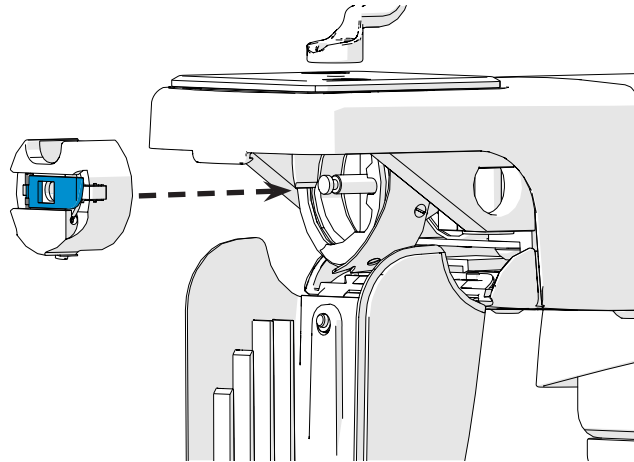

- 9 Close the hook assembly cover.

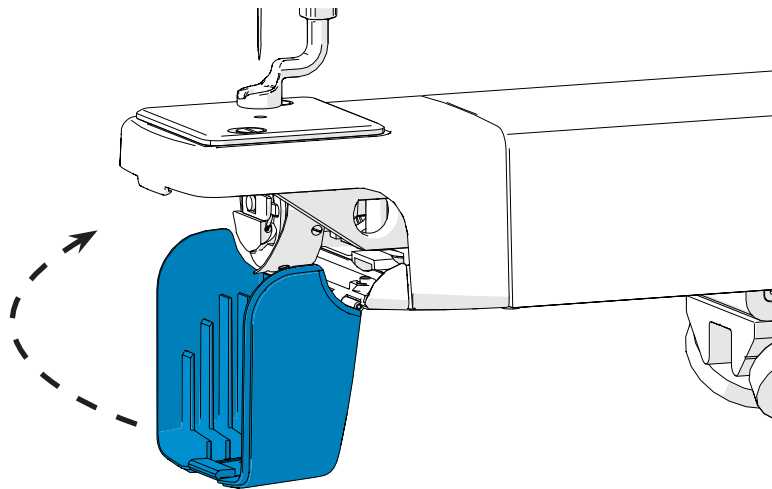

Task 11 - Threading the Machine

Before threading the machine, make sure you've selected quality thread for your project. Choosing the right thread for the machine can prevent the thread from breaking or tangling up under the needle plate. Note the following:

- This machine uses cone-style thread, not thread from a spool. Do not use spool thread unless the spool accessory has been installed.



- Choose thread that is strong enough to pass the yank test, and re-test thread as it ages. Thread strength can diminish over time.

- Hold the cone in one hand and the end of thread in the other.

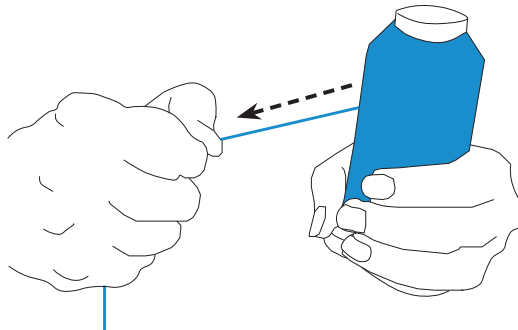

- Tug on the thread. If the thread snaps easily, it may be too brittle to use for quilting.

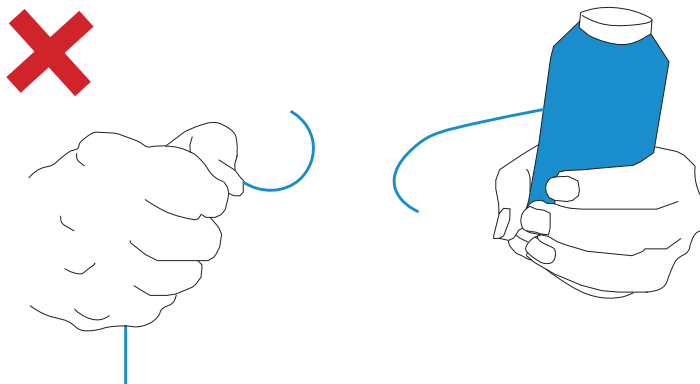

Part Three | Preparing to Quilt

Task 11 - Threading the Machine (continued)

The following diagram outlines the path the thread (shown in blue) must take through the machine.

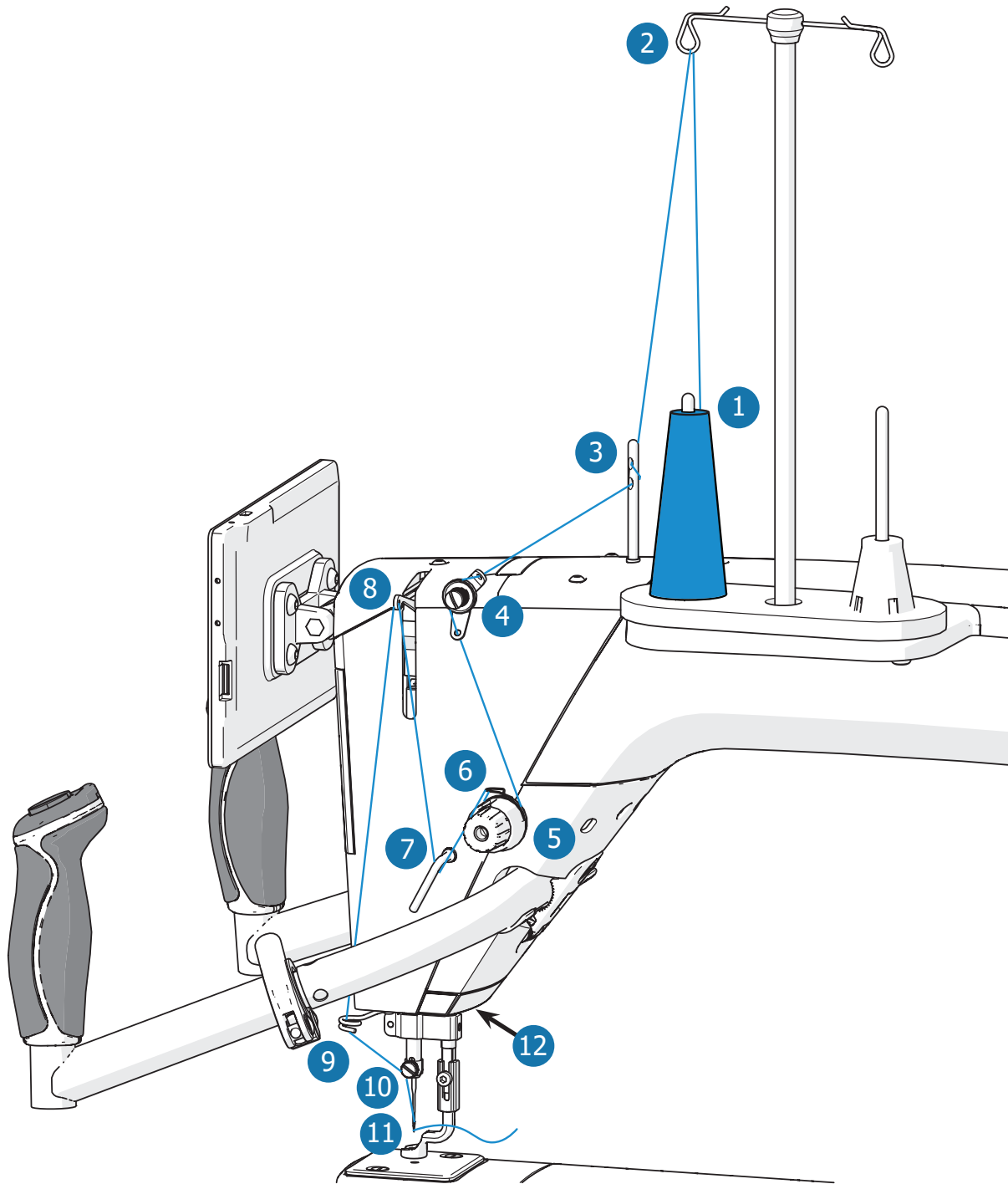

- | | | |
|--------------------------|--------------------------|-------------------------|
| 1 Thread Cone | 5 Large Thread Tensioner | 9 Bottom Thread Guide |
| 2 Thread Mast Guide Loop | 6 Check Spring | 10 Eyelet of Needle Bar |
| 3 Thread Guide Rod | 7 Thread Guide | 11 Eye of Needle |
| 4 Small Thread Tensioner | 8 Take-up Lever | 12 Thread Cutter |

- 1 Rotate the **hand wheel** or press needle up on the display to raise the needle to the top position.

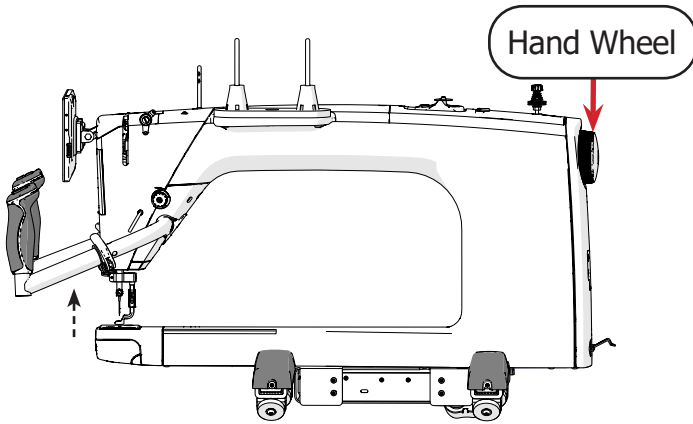

- 2 For your safety, press the **Menu** icon on the display to go to the Settings menu; this prevents the machine from stitching.

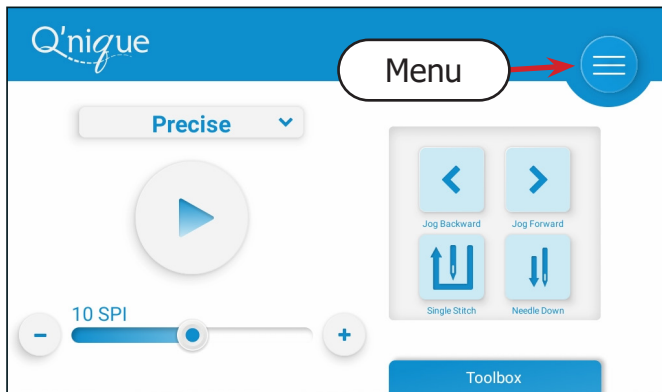

- 3 Slide the thread cone down onto the front **thread stand**.

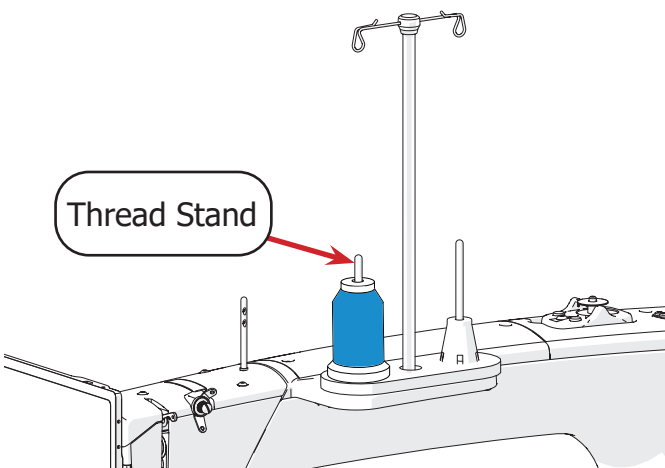

- 4 Pull the thread up, through the **thread mast guide loop** directly above the thread cone.

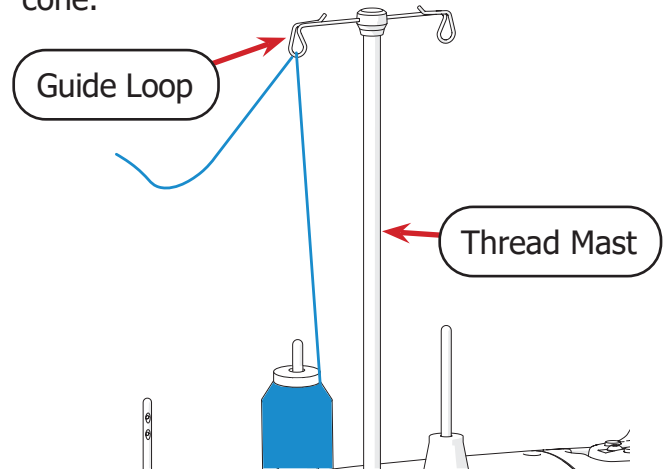

- 5 Feed the thread through the top hole of the **thread guide rod**. Wrap the thread around to the back of the guide and insert through the bottom hole.

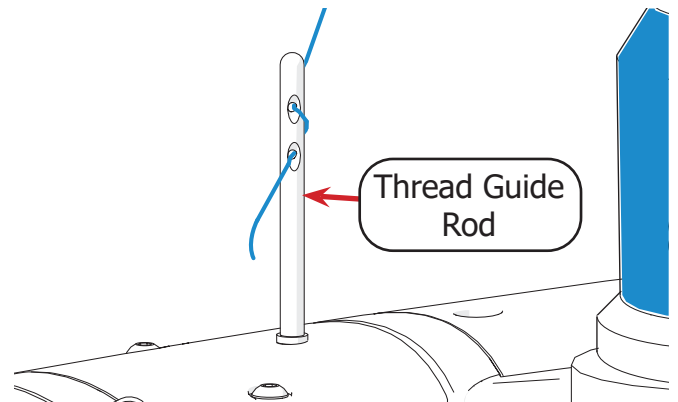

- 6 Run the thread through the top hole on the **small thread tensioner**. Then slip the thread between the two discs, and through the bottom hole.

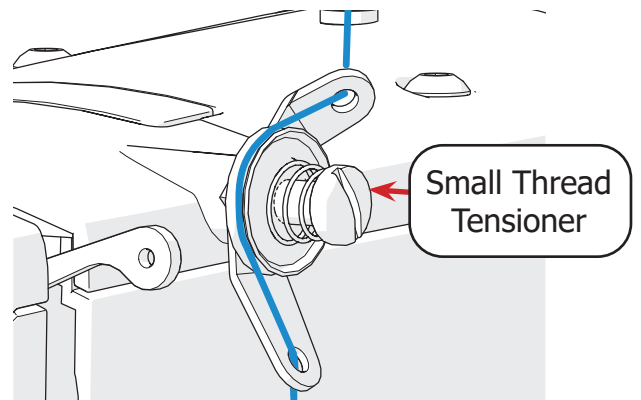

Part Three | Preparing to Quilt

Task 11 - Threading the Machine (continued)

- 7 Floss the thread between the discs on the **large thread tensioner**. Wrap the thread over the **check spring**.

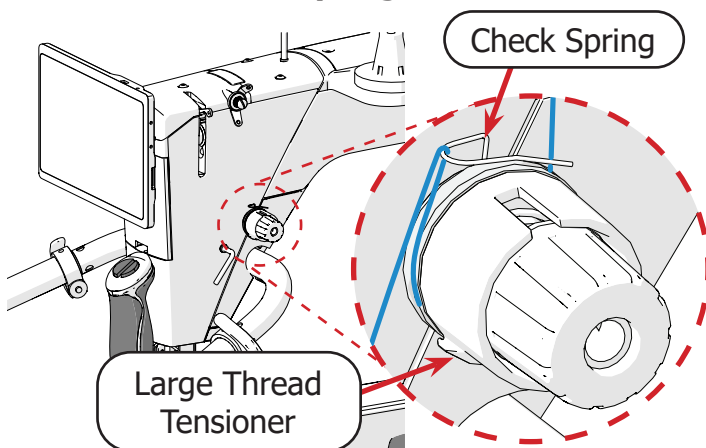

- 8 Next, run the thread under the **thread guide** next to the large thread tensioner.

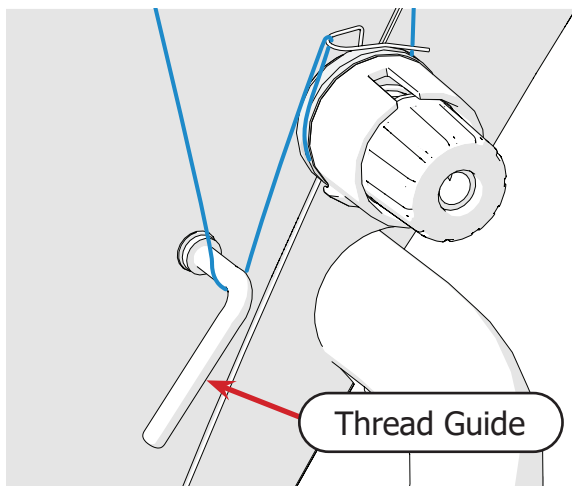

- 9 Pull the thread through the hole in the **take-up lever**.

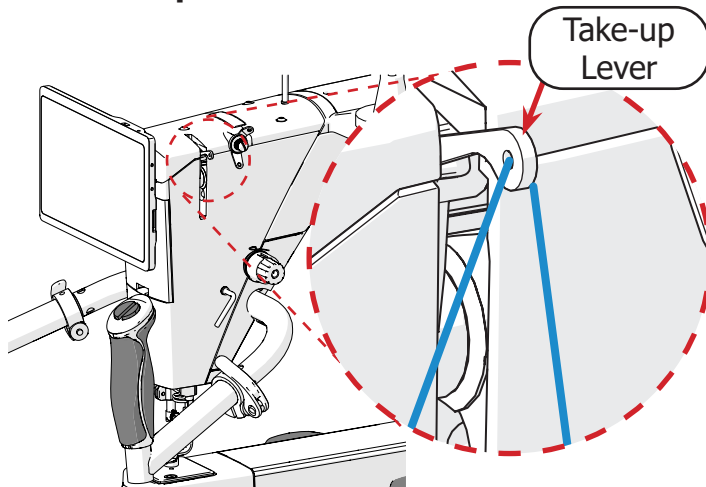

- 10 Pass the thread down through the **bottom thread guide** on the way to the needle.

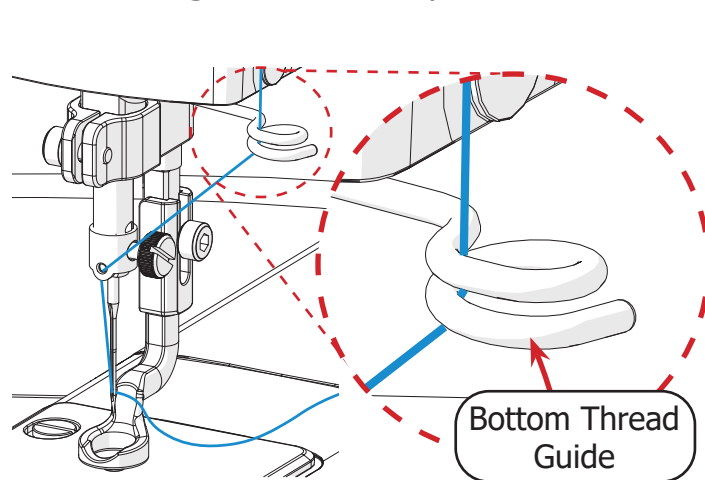

- 11 Now pass the thread through the front of the **needle bar eyelet**, located above the needle.

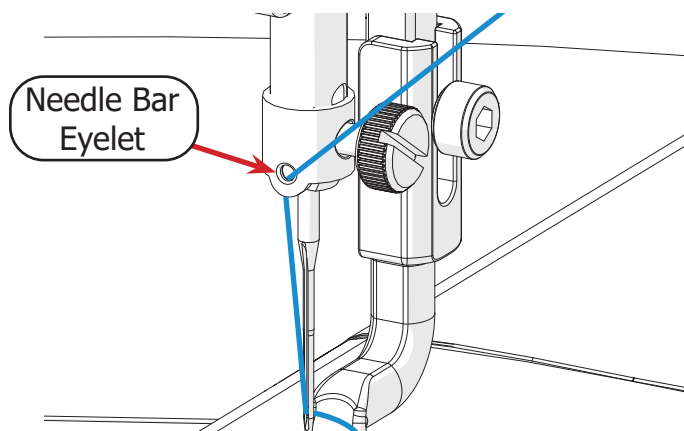

- 12 Thread through the **eye of the needle**.

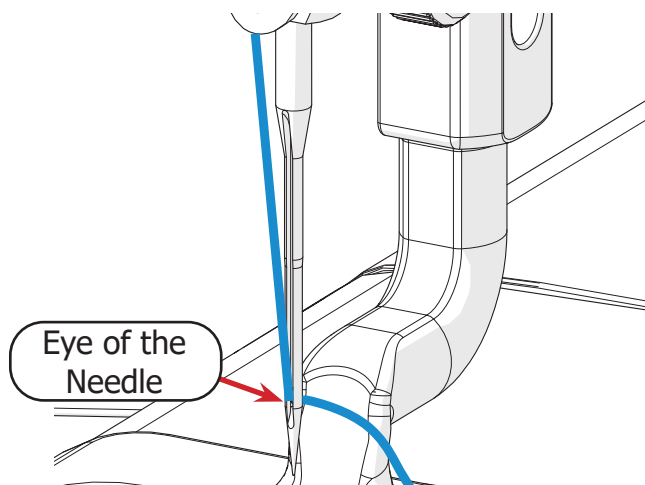

- 13 Loop excess thread over the **thread cutter** on the left of the machine to cut the thread.

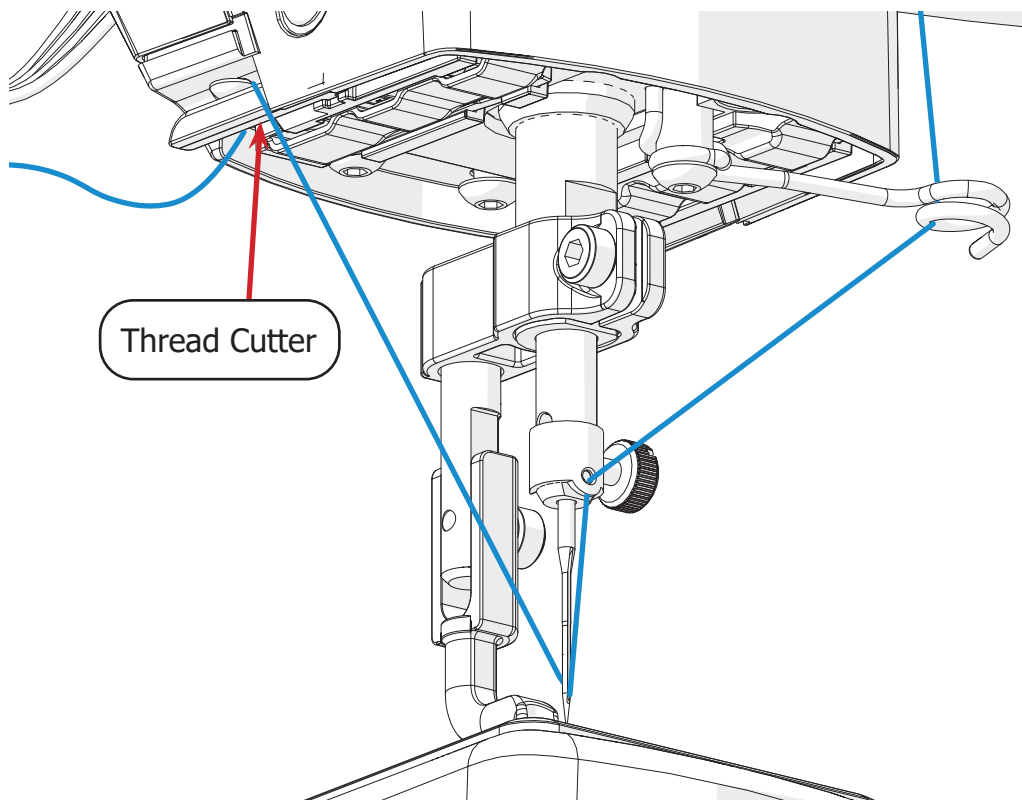

Congratulations! You have completed Part Three of this manual.

If you are assembling a new frame, turn to Part Three of your frame manual. If your frame manual is not broken into parts, follow the manual's directions to:

- Install and adjust the rails
- Install frame handwheel (if applicable)
- Install the bungee clamps (if applicable)
- Adjust the carriage stop (Cutie Frame only)
- Level the frame (if applicable)

If you are not assembling a new frame but are installing Quilter's Creative Touch (previously called QuiltMotion) onto your frame, turn to Part Three of your Quilter's Creative Touch manual.

If you are installing your machine onto a frame that is already fully assembled and are not installing Quilter's Creative Touch at this time, continue to Part Four of this manual on page 42.

Part Four

If your frame isn't fully assembled at this time, it is recommended to complete Part Three in your frame manual, Part Three in your Quilter's Creative Touch (previously called QuiltMotion) manual (optional), and Part Four of your frame manual before you continue.

Progress Checkpoint:

Have you:

- Installed your frame's rails.
- Adjusted the rails to work with your machine.
- Installed frame handwheel (applicable frames only)
- Installed bungee clamps (applicable frames only)
- Adjusted the carriage stop (Cutie Frame only)
- Leveled the frame (applicable frames only)

Have you:

- Completed Quilter's Creative Touch Part Three (optional)

Have you:

- Prepared your frame for fabric installation
- Installed your quilt onto your frame

Quilting

This section of the manual covers how to use your machine to quilt.

Choosing Machine Settings	page 44
Using the Handlebar Controls	page 46
Using the Precise Quilting Mode	page 47
Using the Cruise Quilting Mode	page 49
Using Manual Quilting Mode	page 51
Using Baste Quilting Mode	page 53
Using the Bobbin Estimator Tool.....	page 55
Using the Edge Warning.....	page 57
Adjusting Thread Tension	page 60
Taking Measurements	page 63
Making Calculations	page 65
Tracking Stitch Count & Run Time	page 66
Getting Started	page 67

Choosing Machine Settings

To customize the settings for the handlebar controls, screen buttons, or warning icons, take the following steps:

- 1 Press the **menu** icon in the top right corner of the screen and select Settings.

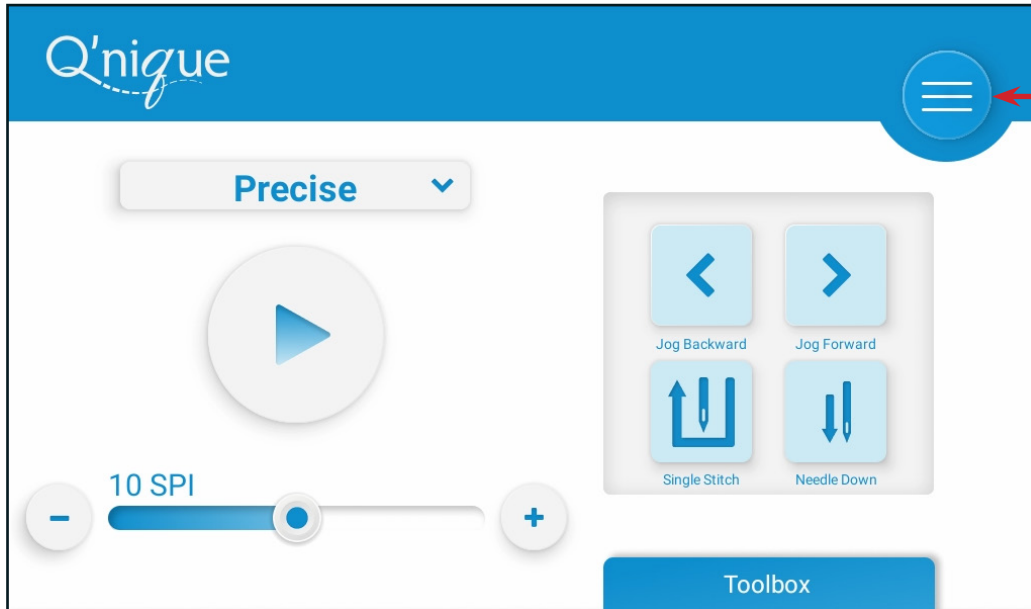

The Settings menu opens.

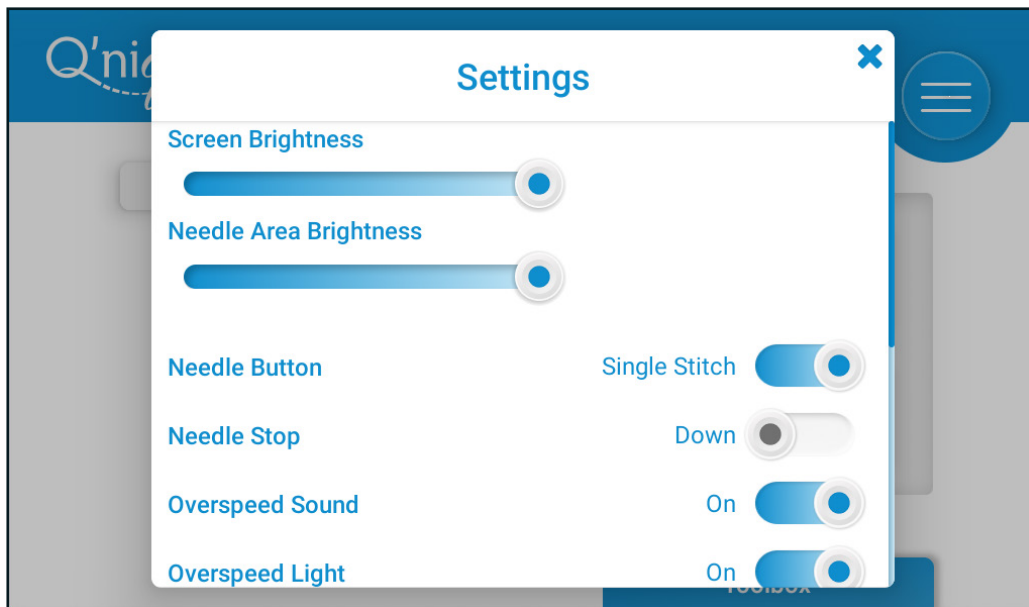

Note: Stitching is disabled while the Settings menu is pulled up.

2 Choose desired settings:

- **Screen Brightness:** Use the sliding button to adjust the brightness of the display.
- **Needle Area Brightness:** Use the sliding button to adjust the brightness of the lamp over the needle area.
- **Needle Button:** Choose whether the needle button on the handlebars will create a single stitch or drop or raise the needle.

Single Stitch: Complete motion of needle up and down to create a stitch.

Needle Up/Down: Move the needle either down into the fabric or up out of the fabric.

- **Needle Stop:** Choose whether the needle will default to the “up” or “down” position when stitching is inactive.
- **Overspeed Sound:** The overspeed alarm can be muted so that there is no beeping when the machine is moved more quickly than the regulated stitching can manage.
- **Overspeed Light:** The overspeed warning light can be deactivated so that it won’t turn on when the machine is moved more quickly than the regulated stitching can manage.
- **Edge Warning Sound:** The edge guard alarm can be muted so that there is no beeping when the machine reaches edge of your set quilting area.
- **Edge Warning Light:** The edge guard warning light can be deactivated so that it won’t turn on when the machine is moved more quickly than the regulated stitching can manage..
- **Click Sound:** Choose whether pressing on-screen buttons should make a sound or not.
- **Stitch Length Units:** Choose to display machine stitch length in millimeters per stitch or stitches per inch.

3 Press the **System Info** button to access the System Information screen. This screen shows the display and firmware versions for your machine (see page 87), along with the date of the last firmware update.

4 Press the **Factory Reset** button to return all settings to their original default status.

5 To return to the main screen, press the X in the top right corner of the settings screen or anywhere outside of the settings screen window.

Using the Handlebar Controls

When first powered up, the machine is in regulated precise quilting mode (see page 49) and can start quilting right away. Please take a moment to review the handlebar controls. These controls are used when quilting. While in the Settings menu, some buttons have a different purpose or do not function (see “Choosing Machine Settings” on page 44 for details).

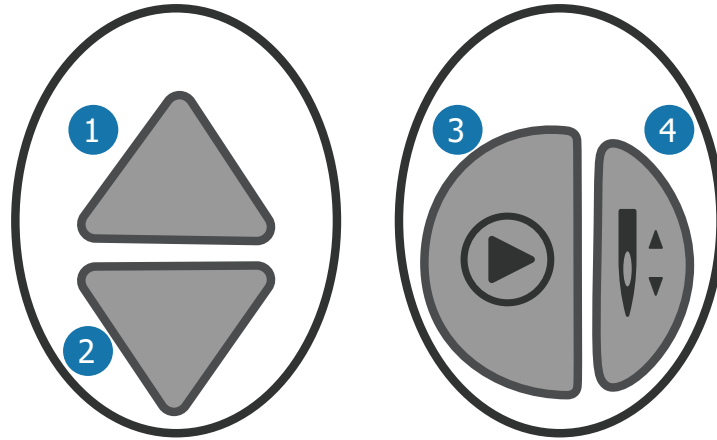

- 1 Increase:** This button increases the number, size, or speed of the stitching, depending upon the quilting mode. For example, in precise quilting mode, this button will increase the number of stitches the machine makes in an inch (SPI) or in a millimeter (SPC).
- 2 Decrease:** This button will decrease the number, size, or speed of the stitching depending upon the quilting mode.
- 3 Start/Stop Quilting:** Press to start or stop stitching.
- 4 Needle Button:** Press to create a single single stitch or to toggle the needle to the up or down position, based upon settings (see “Choosing Machine Settings” on page 44 for details).

Using the Precise Quilting Mode

The machine defaults to precise quilting mode when turned on. In this regulated quilting mode, you select the stitch length you want and the machine will adjust to help make more consistent stitches as you move the machine faster or slower or change direction. It will only stitch when you move the machine, which helps with patterns that have corners or crisp points.

To reach this quilting mode, press the **select quilting mode** button and select **Precise**.

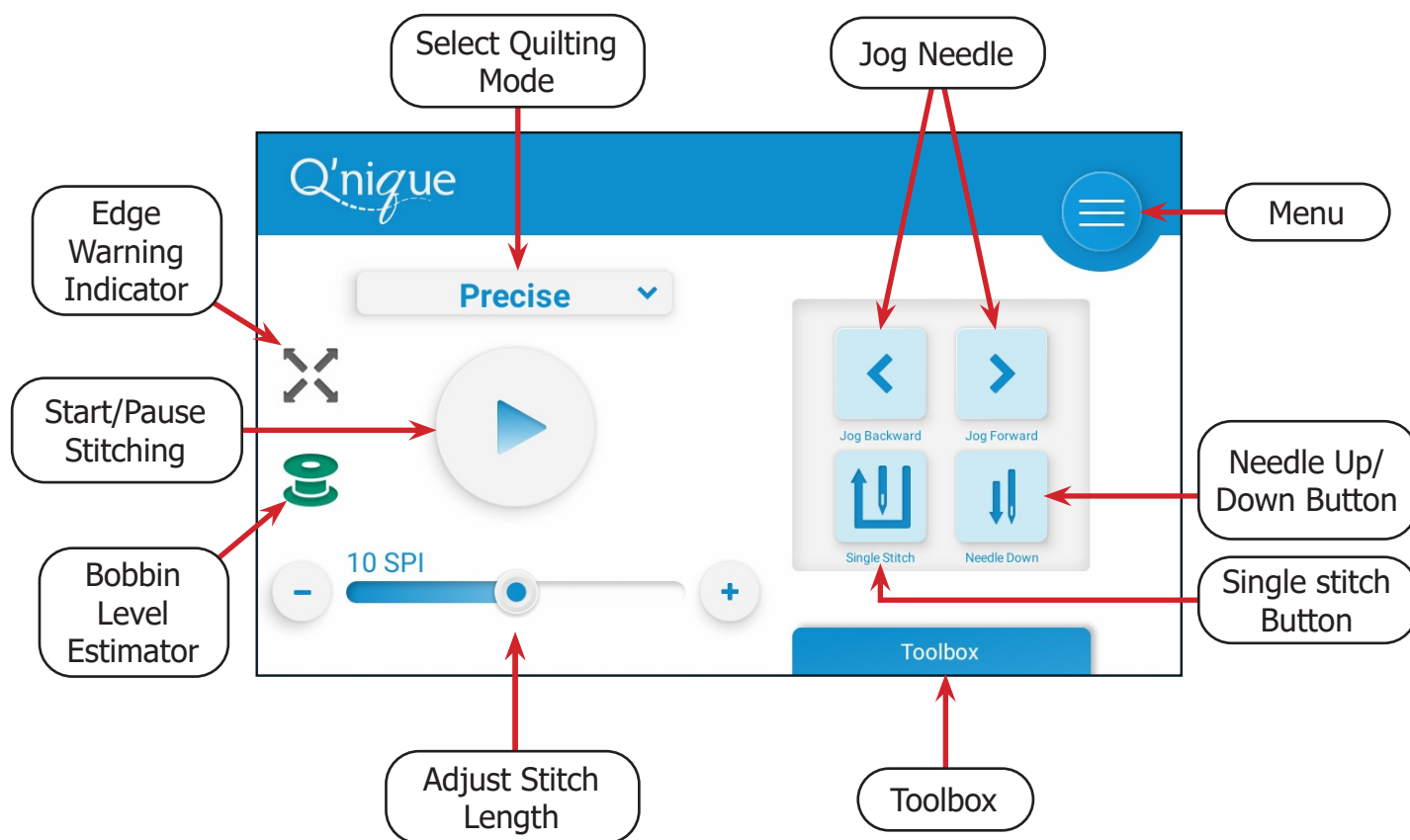

To quilt in regulated precise quilting mode, take the following steps:

- 1 Confirm that the **stitch length**, measured in stitches per inch or stitches per centimeter, is the desired length. Note: To change units, go to the **Settings** menu (see page 44).

Use the **-** **+** symbols or the sliding bar to adjust the stitches per inch. Higher SPI means shorter stitch length.

- 2 When stitching is inactive, press the single stitch button or needle up/down button on the display to make single stitches. This can also be done with the stitch button on the right handle, depending on settings. To switch the type of stitch created with the handle button, go to the Settings menu (see page 44).

Note: While stitching is active, the **single stitch** and **needle up/down buttons** on the display and the **needle button** on the handlebar controls are disabled.

Using the Precise Quilting Mode (continued)

- 3 Position the quilting machine over the quilt. If needed, use the **needle jog** buttons to move the needle closer or farther from the fabric in small increments to help place your first stitch.

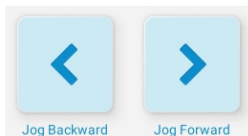

Press to move the needle up or down in small increments.

- 4 Moving the machine too quickly while quilting can reduce the quality of the stitch regulation. If the machine is moved too quickly, an alarm will sound, a red LED light will shine on the needle area, and the **start stitching button** on the display will turn red. Slow the machine's movement to turn off the alarm, light, and display alert. Both the alarm and the display alert can be deactivated in the **Settings** menu.
- 5 When activated, the **bobbin estimator** will show on the left side of the display. For instructions on how to use the bobbin level estimator, see page 55.
 - When the icon is green, the bobbin is estimated to be between 21% and 100% full.
 - When the icon is yellow, the bobbin is estimated to be between 11% and 20% full.
 - When the icon is red, the bobbin is estimated to be under 10% full.
- 6 When activated, the **edge warning indicator** will display on the left side of the screen. This indicator will turn red when you reach the edge of the set quilting area. For instructions on how to use the edge warning alert, see page 57.
- 7 You may find that you need to take measurements or do quick calculations while you quilt. Press **Toolbox** to access the calculator and measure tools.
- 8 To deactivate stitching, press the start/stop quilting button on the display or the handlebars. The needle will move into the needle stop position indicated in the Settings menu (see page 44).

Using the Cruise Quilting Mode

Cruise mode is another regulated mode. You select the stitch length you want and the machine will adjust to help make more consistent stitches as you move the machine faster or slower or change direction. However, the machine will continue to stitch in place (at the minimum speed) if you stop moving the machine. This mode is helpful for continuous, smooth, or curvy designs.

To switch to cruise quilting mode, press the **select quilting mode** button and select **Cruise**.

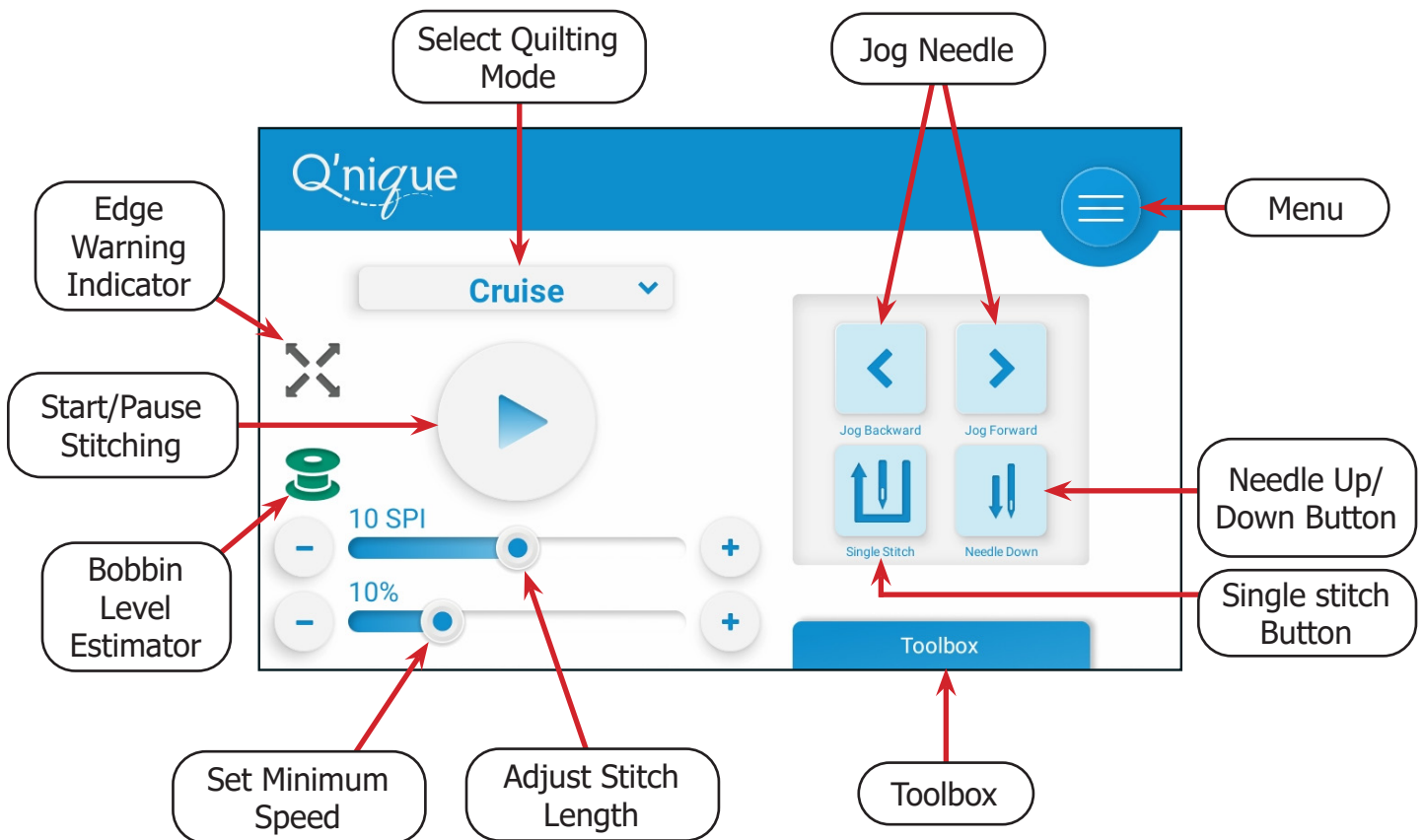

To quilt in cruise quilting mode, take the following steps:

- 1 Confirm that the **stitch length**, measured in stitches per inch or stitches per centimeter, is the desired length. Note: To change units, go to the **Settings** menu (see page 44).

Use the symbols or the sliding bar to adjust the stitches per inch. Higher SPI means shorter stitch length.

- 2 Determine the **minimum speed** the machine will stitch at when stitching is active but the machine is not being moved. This can be set from 5% to 25% of the machine's top speed of 2600 stitches per minute.

Use the symbols or the sliding bar to adjust the minimum speed

Using the Cruise Quilting Mode (continued)

- 3 When stitching is inactive, press the single stitch button or needle up/down button on the display to make single stitches. This can also be done with the needle button on the right handle, depending on settings. To switch the type of stitch created with the handle button, go to the Settings menu (see page 44).

Note: While stitching is active, the **single stitch** and **needle up/down buttons** on the display and the **needle button** on the handlebar controls are disabled.

- 4 Position the quilting machine over the quilt. If needed, use the **needle jog** buttons to move the needle closer or farther from the fabric in small increments to help place your first stitch.



Press to move the needle up or down in small increments.

- 5 Moving the machine too quickly while quilting can reduce the quality of the stitch regulation. If the machine is moved too quickly, an alarm will sound and the **start stitching button** on the display will turn red. Slow the machine's movement to turn off the alarm and display alert. Both the alarm and the display alert can be deactivated in the **Settings** menu.
- 6 When activated, the **bobbin estimator** will show on the left side of the display. For instructions on how to use the bobbin level estimator, see page 55.
 - When the icon is green, the bobbin is estimated to be between 21% and 100% full.
 - When the icon is yellow, the bobbin is estimated to be between 11% and 20% full.
 - When the icon is red, the bobbin is estimated to be under 10% full.
- 7 When activated, the **edge warning indicator** will display on the left side of the screen. This indicator will turn red when you reach the edge of the set quilting area. For instructions on how to use the edge warning alert, see page 57.
- 8 You may find that you need to take measurements or do quick calculations while you quilt. Press **Toolbox** to access the calculator and measure tools.
- 9 To deactivate stitching, press the start/stop quilting button on the display or the handlebars. The needle will move into the needle stop position indicated in the Settings menu (see page 44).

Using Manual Quilting Mode

In this quilting mode, the machine produces stitches at a certain speed. It's up to the quilter to move the machine the distance needed to get the desired stitch length. This mode is useful for small, continuous patterns.

To switch to manual quilting mode, press the **select quilting mode** button and select **Manual**.

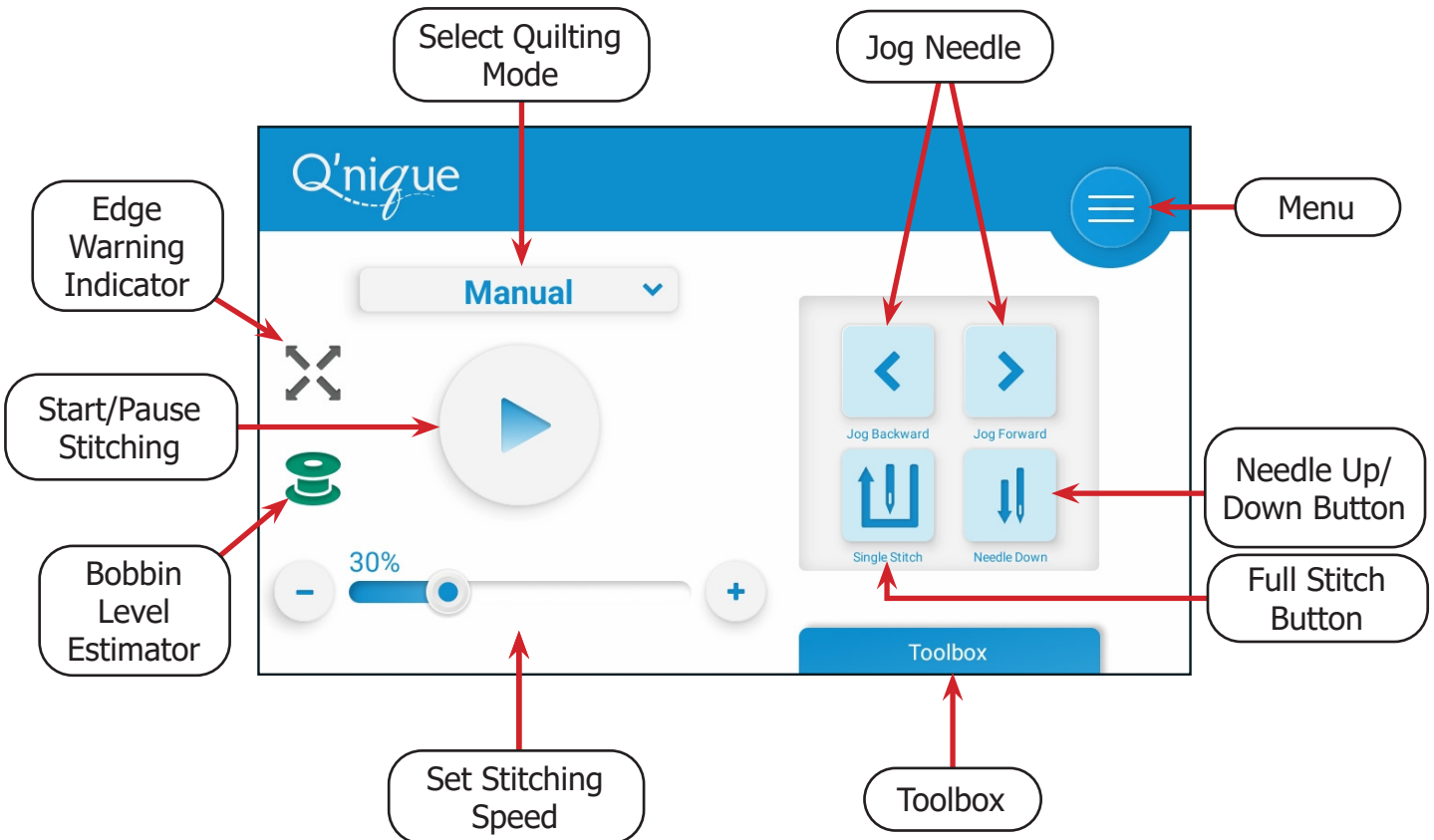

To quilt in manual quilting mode, take the following steps:

- 1 Confirm that the **stitch speed** is set to the desired speed. The speed is measured as a percentage of the machine's maximum speed of 2600 stitches per minute.

Use the symbols or the sliding bar to adjust the machine speed

- 2 When stitching is inactive, press the single stitch button or needle up/down button on the display to make single stitches. This can also be done with the needle button on the right handle, depending on settings. To switch the type of stitch created with the handle button, go to the Settings menu (see page 44).

Note: While stitching is active, the **single stitch** and **needle up/down buttons** on the display and the **needle button** on the handlebar controls are disabled.

Using Manual Quilting Mode (continued)

- 3 Position the quilting machine over the quilt. If needed, use the **needle jog** buttons to move the needle closer or farther from the fabric in small increments to help place your first stitch.

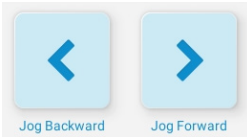

Press to move the needle up or down in small increments.

- 4 When activated, the **bobbin estimator** will show on the left side of the display. For instructions on how to use the bobbin level estimator, see page 55.
 - When the icon is green, the bobbin is estimated to be between 21% and 100% full.
 - When the icon is yellow, the bobbin is estimated to be between 11% and 20% full.
 - When the icon is red, the bobbin is estimated to be under 10% full.
- 5 When activated, the **edge warning indicator** will display on the left side of the screen. This indicator will turn red when you reach the edge of the set quilting area. For instructions on how to use the edge warning alert, see page 57.
- 6 You may find that you need to take measurements or do quick calculations while you quilt. Press **Toolbox** to access the calculator and measure tools.
- 7 To deactivate stitching, press the start/stop quilting button on the display or the handlebars. The needle will move into the needle stop position indicated in the Settings menu (see page 44).

Using Baste Quilting Mode

Use baste mode to create loose, temporary stitches around the edge of your quilt top to hold layers of fabric together while quilting.

To switch to baste quilting mode, press the **select quilting mode** button and select **Baste**.

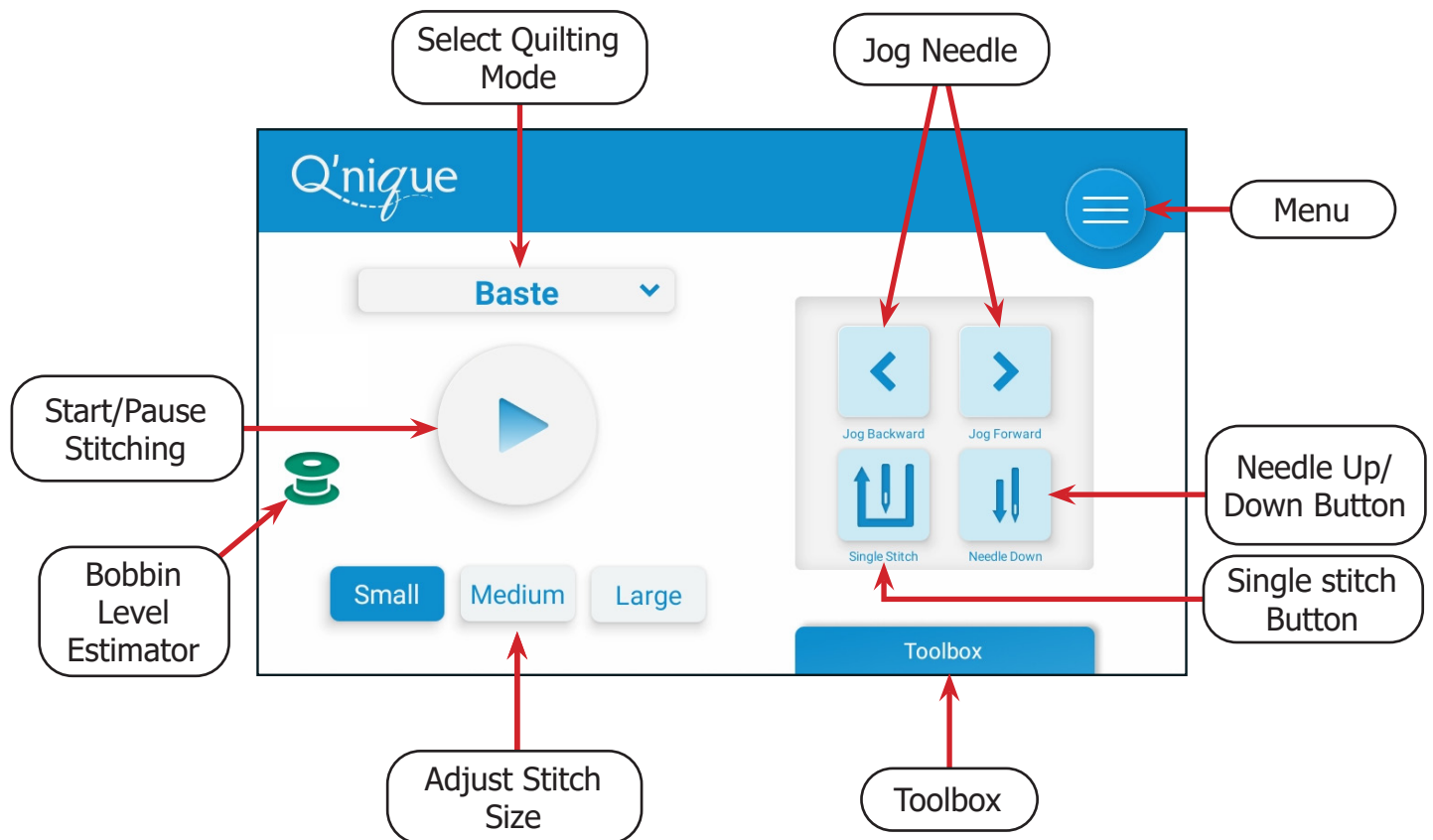

To quilt in baste quilting mode, take the following steps:

- 1 Confirm that the **stitch size**, (small, medium, or large) is the desired length.
- 2 When stitching is inactive, press the single stitch button or needle up/down button on the display to make single stitches. This can also be done with the needle button on the right handle, depending on settings. To switch the type of stitch created with the handle button, go to the Settings menu (see page 44).

Note: While stitching is active, the **single stitch** and **needle up/down buttons** on the display and the **needle button** on the handlebar controls are disabled.

- 3 Position the quilting machine over the quilt. If needed, use the **needle jog** buttons to move the needle closer or farther from the fabric in small increments to help place your first stitch.

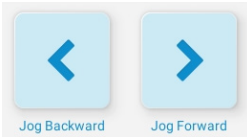

Press to move the needle up or down in small increments.

- 4 Moving the machine too quickly while quilting can reduce the quality of the stitch regulation. If the machine is moved too quickly, an alarm will sound and the **start stitching button** on the display will turn red. Slow the machine's movement to turn off the alarm and display alert. Both the alarm and the display alert can be deactivated in the **Settings** menu.
- 5 When activated, the **bobbin estimator symbol** will show on the left side of the display. For instructions on how to use the bobbin level estimator, see page 55.
 - When the icon is green, the bobbin is estimated to be between 21% and 100% full.
 - When the icon is yellow, the bobbin is estimated to be between 11% and 20% full.
 - When the icon is red, the bobbin is estimated to be under 10% full.
- 6 Edge Warning is automatically deactivated in Baste Mode
- 7 You may find that you need to take measurements or do quick calculations while you quilt. Press **Toolbox** to access the calculator and measure tools.
- 8 To deactivate stitching, press the start/stop quilting button on the display or the handlebars. The needle will move into the needle stop position indicated in the Settings menu (see page 44).

Note: Edge warning is inactive while in the baste quilting mode.

Using the Bobbin Estimator Tool

The bobbin estimator calculates the likely amount of thread remaining on the bobbin. To achieve the closest estimate, information must be accurately entered into the Bobbin Estimator screen. Take the following steps to use the bobbin estimator tool:

- 1 To access the bobbin estimator tool, tap on the **Toolbox** at the bottom of any quilting mode screen and select the **bobbin estimator**.

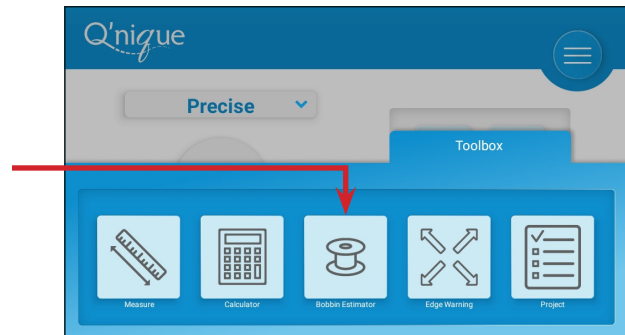

- 2 Press **Select Bobbin**. The drop-down menu will show a list of any bobbins you've added in the past. To add a bobbin, press **Add Bobbin**. An on-screen keyboard will appear so you can name the new bobbin.

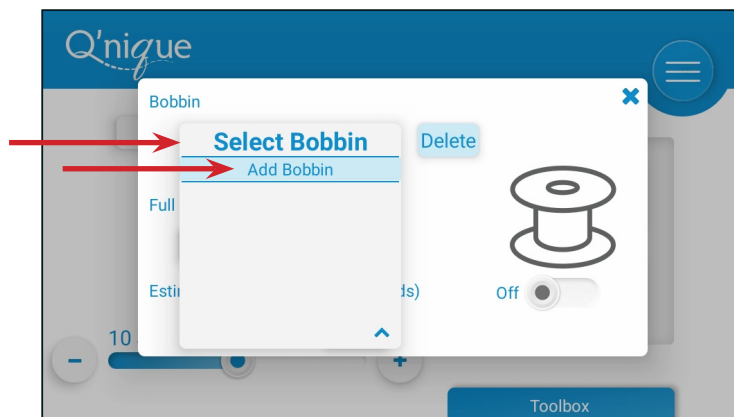

Tip: Choose a bobbin name that will make it easy to identify which bobbin you're using so that if you have to swap between partially used bobbins you can be sure to select the correct one from the list.

Name examples: "Ct Light Blue" for light blue cotton, or "Poly Wht 40 Wt" for 40-weight white polyester.

- 3 Enter the estimated number of yards on the bobbin. As a starting reference, an M-class bobbin fully wound with 40 wt cotton thread is approximately 90 yards. Yardage will vary depending on the fiber and weight of the thread used.

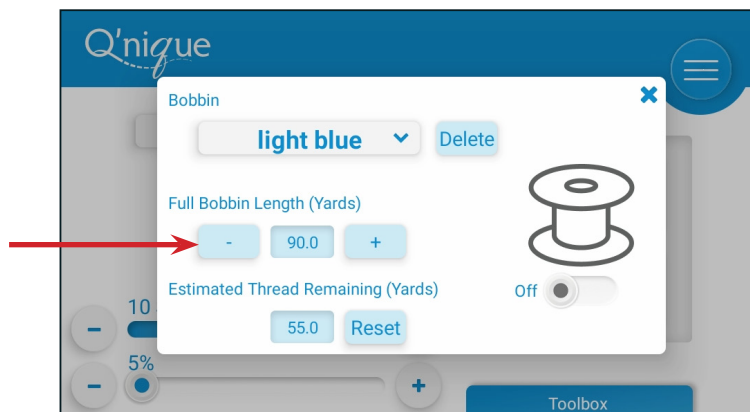

Tip: It may take some practice to estimate the length of a fully wound bobbin. Keep a record of your starting estimate. When you run out of bobbin thread, open the estimator tool and see how much thread remains. Use this information to adjust your starting estimate next time you use the same type of thread.

Using the Bobbin Estimator Tool (continued)

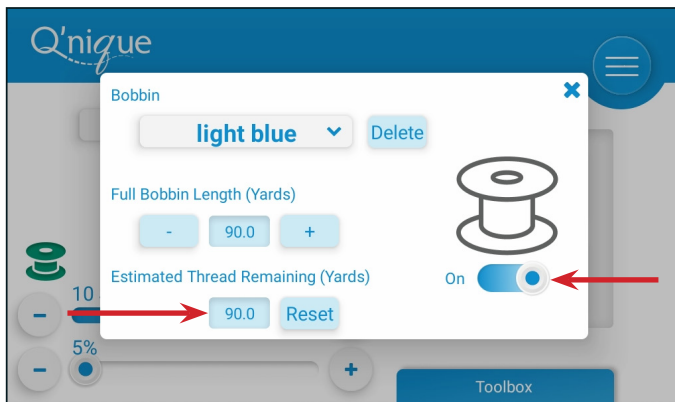

- Turn on the bobbin estimator with the switch on underneath the bobbin image. When **on**, any stitches the machine makes will subtract from the **estimated thread remaining**.

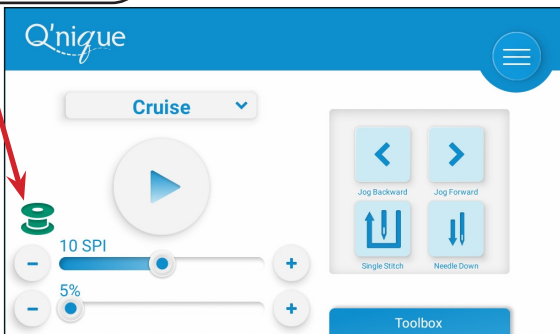

The **bobbin estimator symbol** will also show on the left side of the quilting mode screen when the estimator is on. Color changes notify when the bobbin is estimated to be nearing the end of the thread.

Bobbin Estimator Symbol



-  21% - 100% remaining
-  11% - 20% remaining
-  0% - 10% remaining

Note: Pressing this symbol on a quilting screen will bring up the bobbin estimator tool.

- When the bobbin thread is used up, you can either delete the record of the bobbin or reset it to be used again. **Reset** is recommended if you're planning on winding the bobbin back up with the same thread.

Press **Reset** to restore the estimated thread remaining to the full estimate.

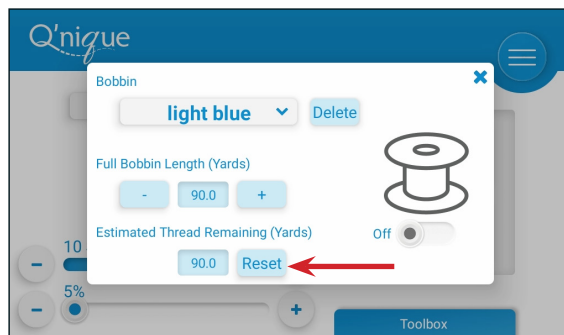

To delete a bobbin, select it from the drop-down and press **delete**.

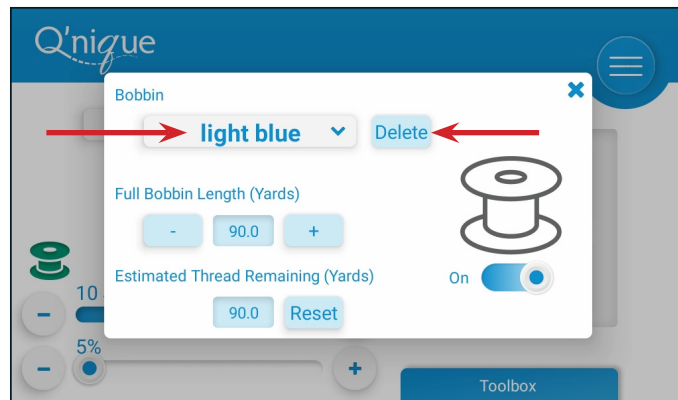

- To return to the main quilting screen, press the **X** in the top right corner or press anywhere outside of the bobbin estimator screen.

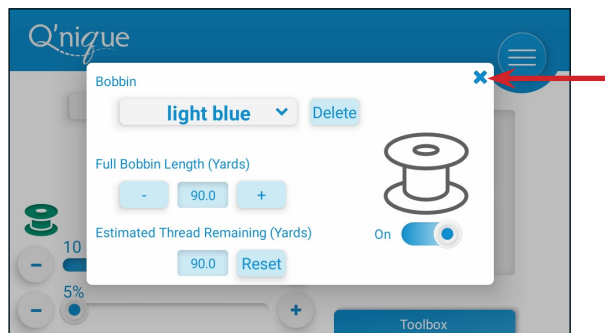

Using the Edge Warning

The edge warning helps you stay within a “safe area” of your quilt by alerting you when you approach the edge of boundaries you’ve set. Use this tool to avoid hitting the frame rails or to restrain your quilting to a particular section or block.

Note: Edge Warning is automatically deactivated in Baste Mode, so the alarm will not bother you while tacking down your quilt.

Take the following steps to use the edge warning tool:

- 1 To access the edge warning tool, tap on the **Toolbox** at the bottom of any quilting mode screen and select **Edge Warning**.

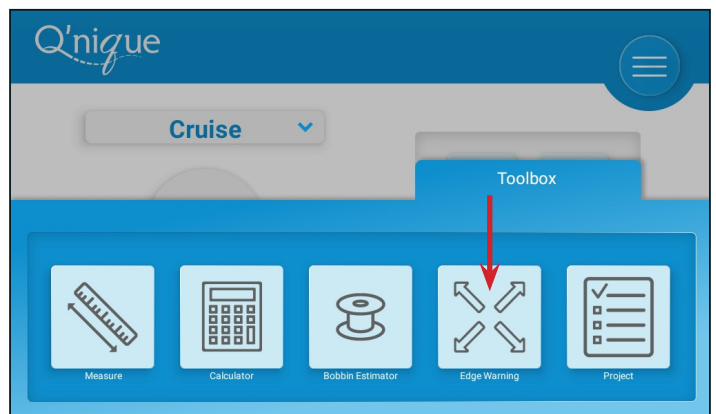
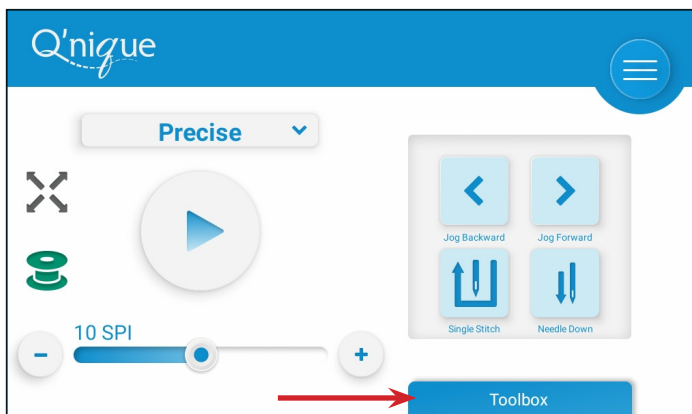

- 2 Move your machine so that your needle is at the top left corner of the area you want to mark as your safe area. Press the **set** button.

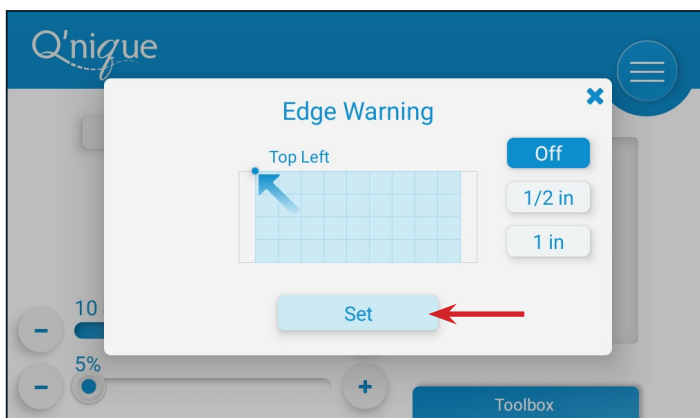

Tip: You can also use the start/stop quilting button on the right handlebar to set the corners of the “safe area.”

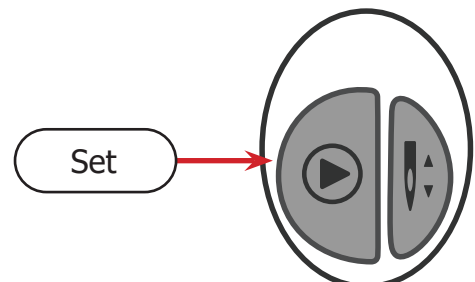

Using the Edge Warning (continued)

- 3 Move your machine so that your needle is at the bottom right corner of the area you want to mark as your safe area. Press the **set** button.

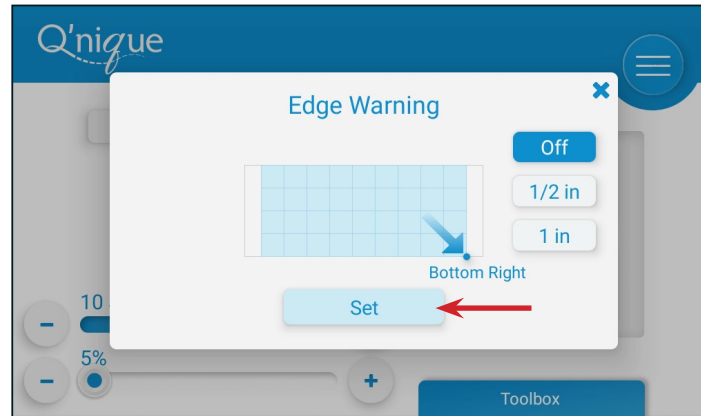

- 4 After marking your boundaries, set the machine to notify you when your needle is within **1/2 inch** or **1 inch** of any of those boundaries. Once this is set, a green check mark will appear to confirm everything saved successfully.

Note: The edge warning symbol will also appear on the main quilting screen. Pressing this symbol on the main quilting screen will bring up the edge warning tool.

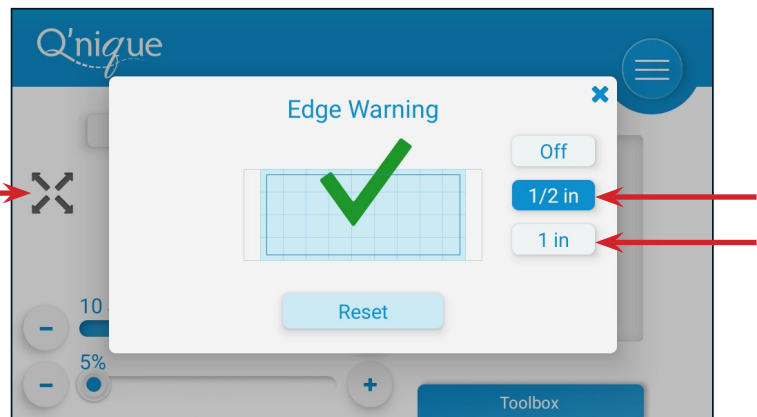

- 5 To return to the main quilting screen, press the X in the top right corner or press anywhere outside of the edge warning screen.

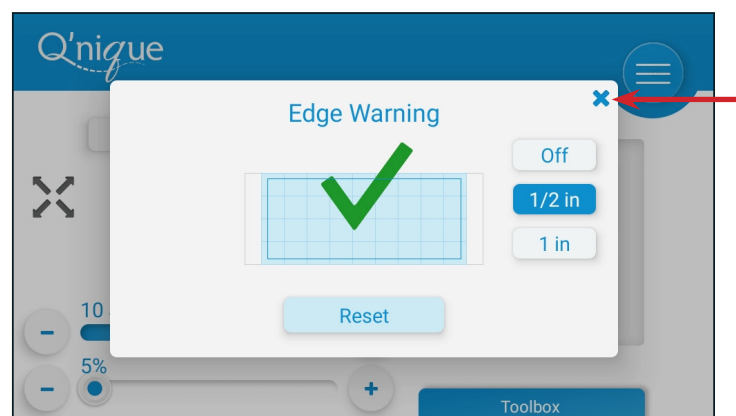

- 6 Whenever you approach or cross the boundaries while quilting, an alarm will sound, a red LED light will shine on the needle area, and the **edge warning symbol** on the left side of the main quilting screen will turn red. These alerts persist until you return to the established "safe area."

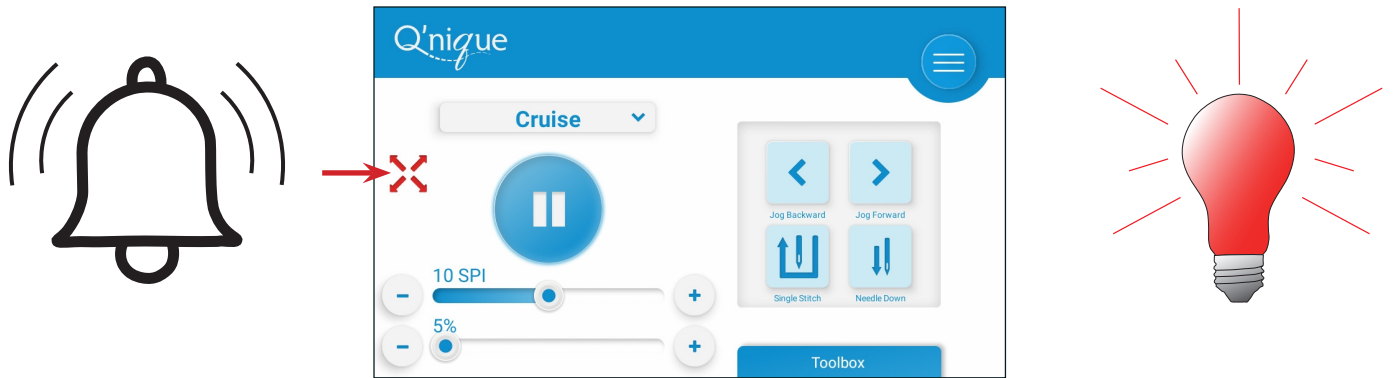

Note: Edge Warning is automatically deactivated in Baste Mode.

- 7 The light and the alarm can each be deactivated in the settings screen (see page 44).



To hide the edge warning symbol on the quilting screen, turn off the edge warning tool from the edge warning screen. This will also deactivate the warning light and alarm.

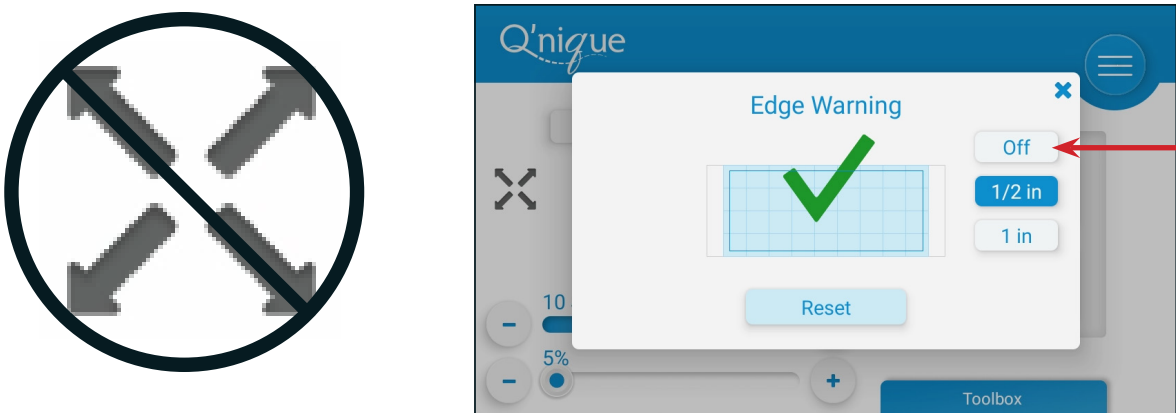

Adjusting Thread Tension

Proper thread tension prevents unwanted puckering, poorly-formed stitches, and malfunctions that can damage the fabric. Test your thread tension on extra materials before sewing on a project.

Tip: Bottom thread tension is the foundation for proper thread tension, and should be set first before setting top tension. Bottom tension is addressed in “Task 10 - Loading the Bobbin Case” on page 34.

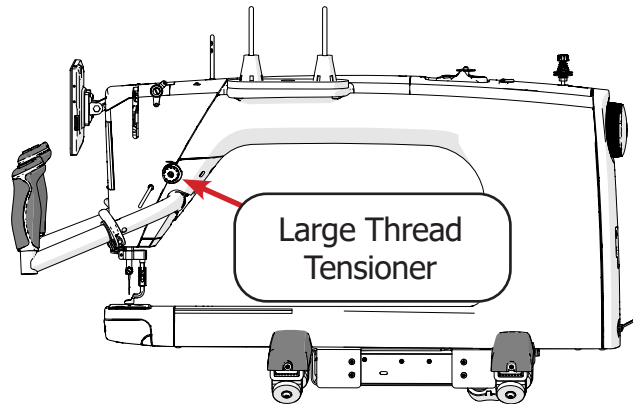

- 1 Loosen the **tension knob** on the large thread tensioner to set the tension to “1.” The bottom of the tension knob lines up with the number that the tension is set to.

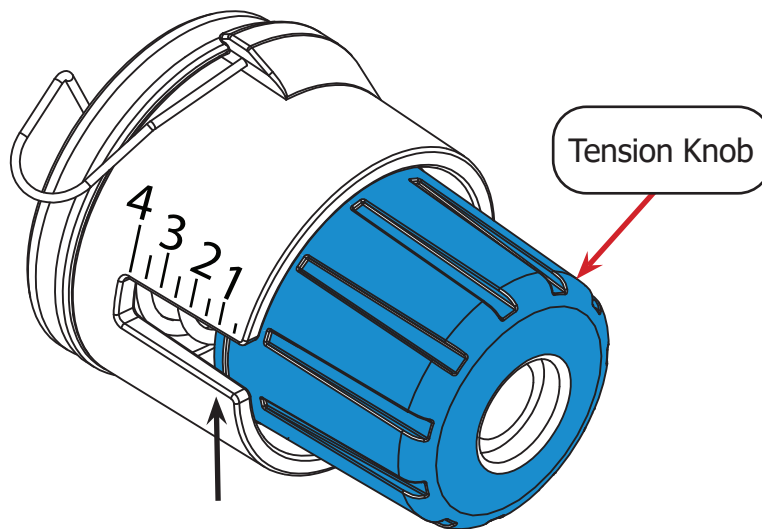

Note: Setting “1” is the lowest tension for the machine. This is an ideal starting place to find the correct top thread tension. Take care not to go past one: the tension knob may unscrew completely and fall off the machine.

- 2 Slowly increase the tension while stitching into scrap material similar to your project. When the thread tension is balanced, the top and bottom thread will knot in the middle of the fabric layers.

**Too Much Top
Tension**



Bottom thread is
pulled to the top
of the fabric.

**Balanced
Tension**



**Too Little Top
Tension**



Top thread is
pulled to the
bottom of the
fabric.

- If the bobbin (bottom) thread is pulled through the top layer of fabric, there is too much top tension. Loosen the tension by turning the large thread tensioner knob counter-clockwise toward the setting "1."

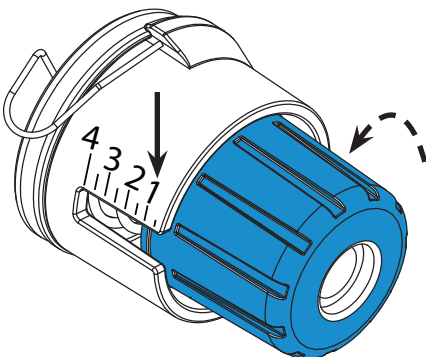

- If the top thread is pulled down through the bottom layer of fabric, there is too little top tension. Increase the tension on the top by turning the large thread tensioner knob clockwise toward setting "4." Stop turning knob when desired tension is achieved.

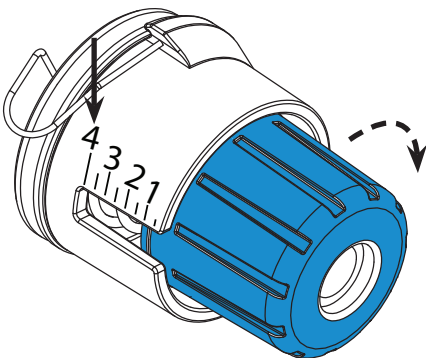

Taking Measurements

Your machine can be used to take measurements across the surface of your quilt.

- 1 To access the measure tool, tap on the **Toolbox** at the bottom of any quilting mode screen and select **Measure**.

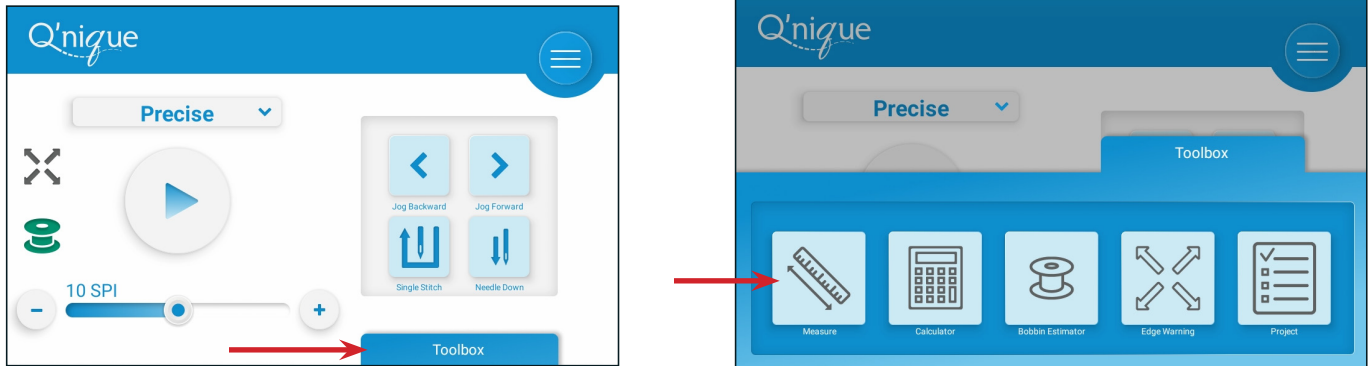

- 2 Select whether you want to measure using inches or centimeters.

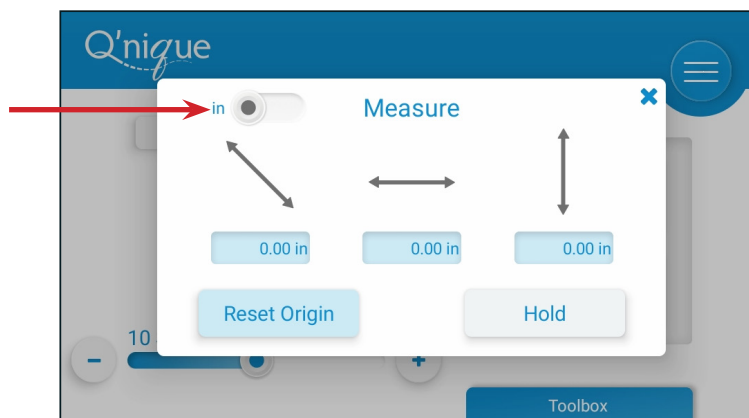

- 3 Move the machine so that the needle is at the position where you want to start your measurement and click the **Reset Origin** button. This origin will be saved until you reset it again.

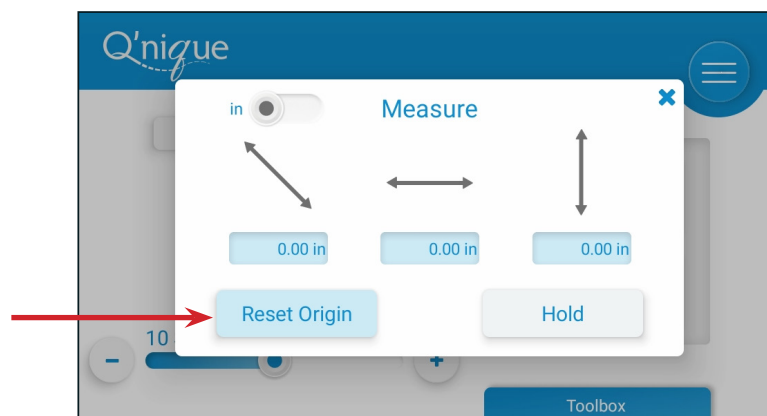

Taking Measurements (continued)

- 4 Move the machine so that the needle is at the end point of your measurement. Press **Hold** to stop measuring and freeze the current measurements on screen.

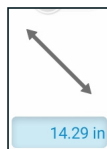
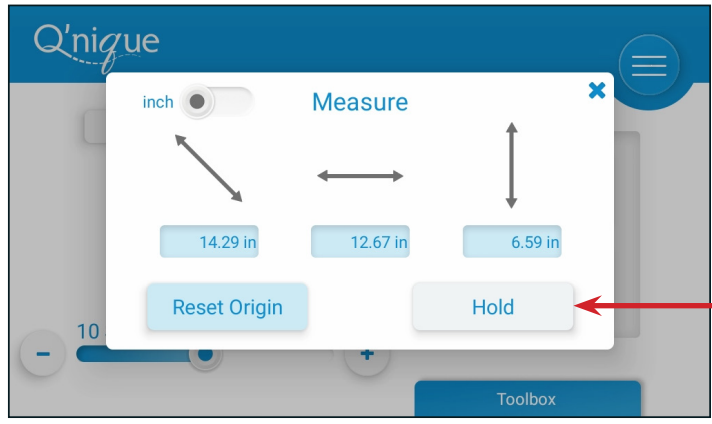

Measures the actual distance from the origin to the end point.



Measures the horizontal distance from the origin.

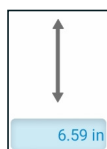

Measures the vertical distance from the origin.

Tip: You can also use the buttons on the right handlebar to reset the origin and hold the measurements.

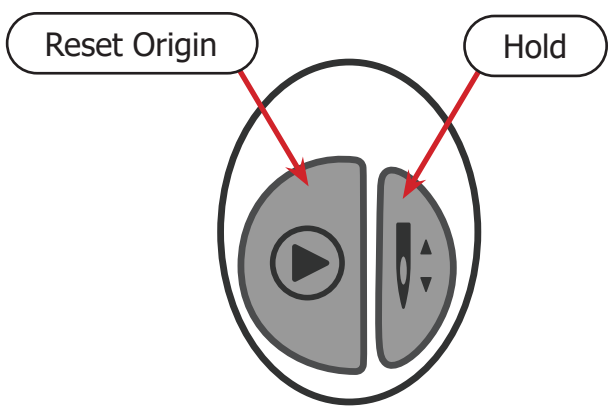

- 5 To resume measuring, press **Hold** a second time.
- 6 To return to the main quilting screen, press the X in the top right corner or press anywhere outside of the measure screen.

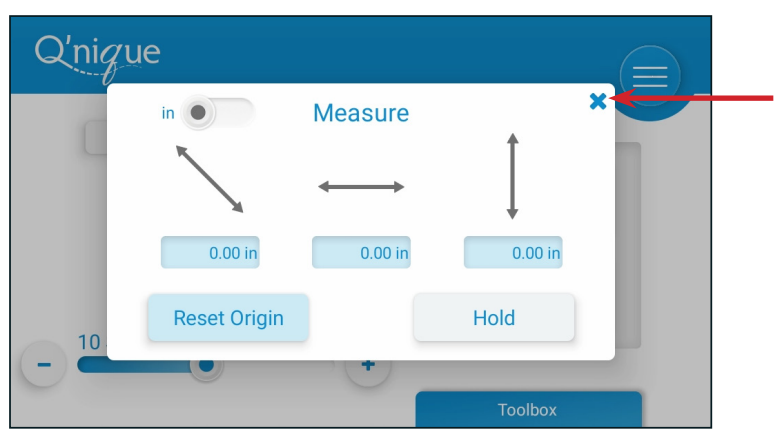

Making Calculations

Your machine can be used to make quick calculations.

- 1 To access the calculator, tap on the **Toolbox** at the bottom of any quilting mode screen and select **Calculator**.

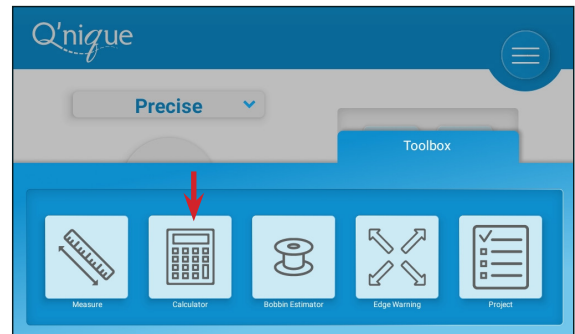
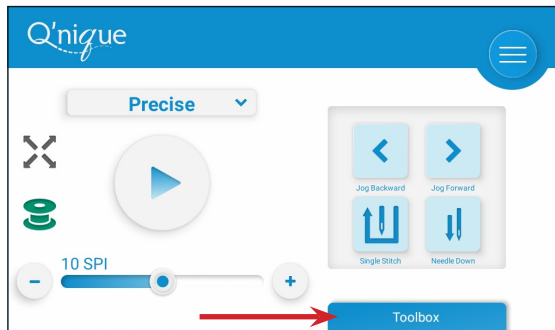

- 2 Use the calculator to add, subtract, multiply, divide, and find percentages.

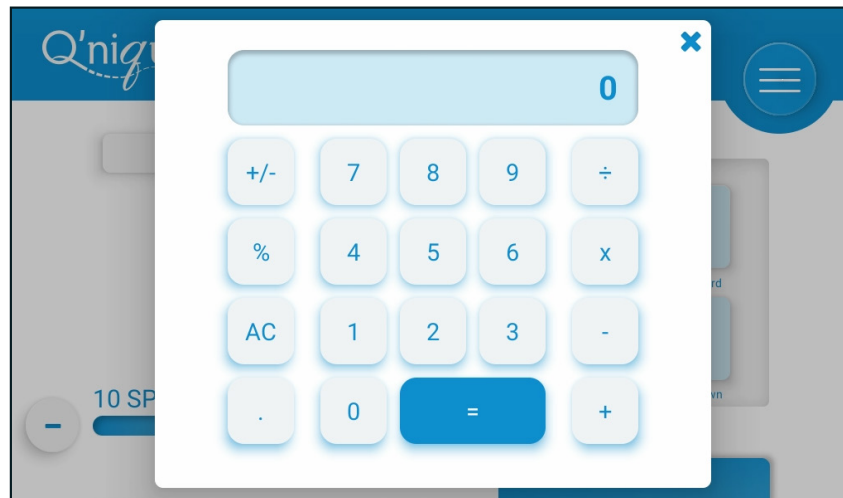

- 3 To return to the main quilting screen, press the X in the top right corner or press anywhere outside of the calculator screen.

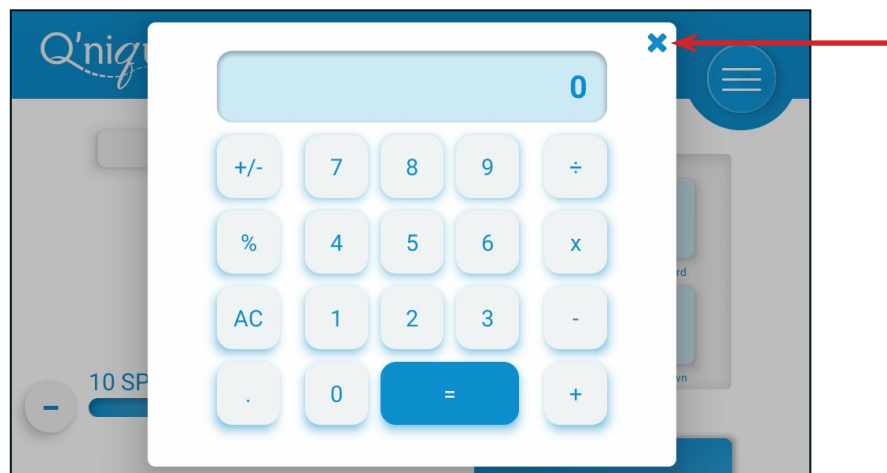

Tracking Stitch Count & Run Time

Use the project tool to track the stitch count and run time over the lifetime of your machine, or for individual projects.

- 1 To access the project tool, tap on the **Toolbox** at the bottom of any quilting mode screen and select **Project**.

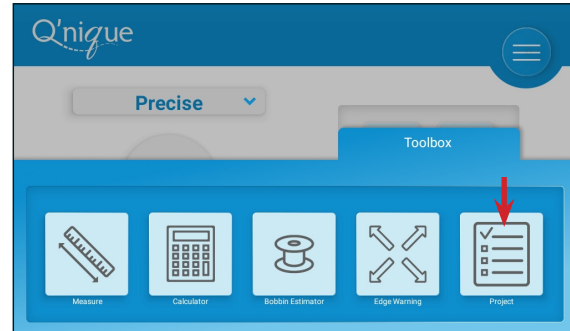
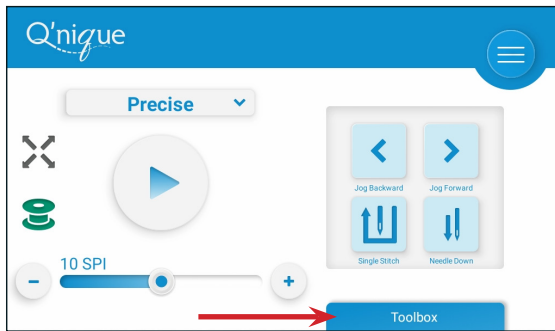

- 2 The stitch tracking screen displays. Lifetime shows the hours the machine has spent running and the number of stitches it has made since it was manufactured. "Project" shows the hours and minutes run and number of stitches created since the counter was last reset.

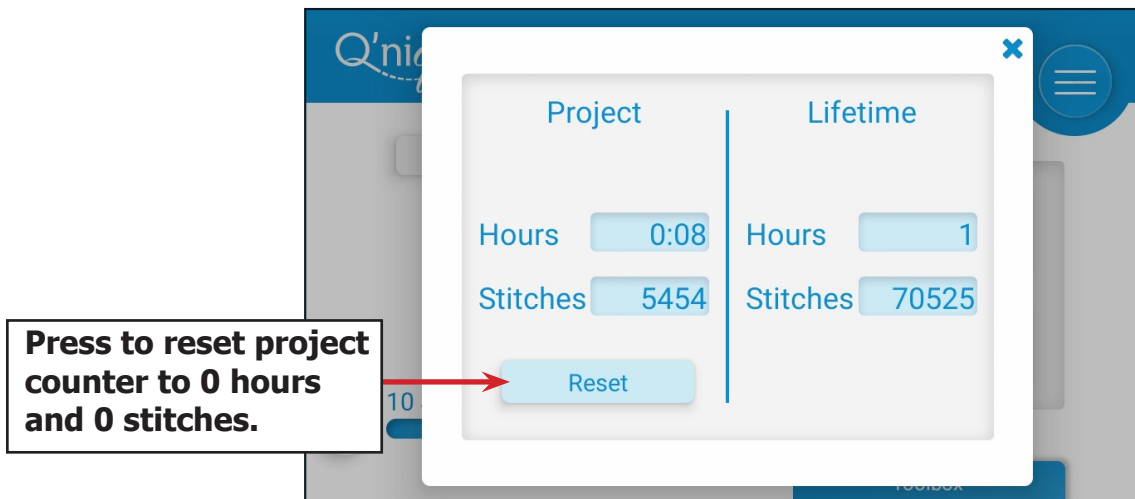

Tip: It's recommended to oil your machine after 20 hours of use. The "Hours Run" counter can help keep track of when your machine is due to be oiled. After cleaning and oiling your machine, press **Reset** to start the counters under **project** back at zero.

The counters under **lifetime** cannot be reset.

Getting Started

Parts & Tools Needed:

Scissors
(not included)

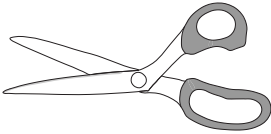

Washable Fabric
Marker/chalk (not
included)

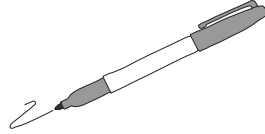

Instructions

With the machine fully assembled, you are ready to begin quilting. Practice on spare fabric to become familiar with the machine's settings and movements so you can start your projects with confidence. It is normal to make mistakes, so don't get discouraged if your stitches don't look perfect right away. Follow the steps in this section to get started and you'll be quilting in no time!

- 1 **Relax!** Take a deep breath and don't be afraid to take it slow.

Make sure that the following items have been completed:

- Your machine is threaded and tensioned.
- Your practice fabric is attached.
- You have established any machine settings you want to use.



- 2 Before you begin stitching, pull up your bobbin thread to prevent the thread tail from dangling underneath the fabric as you quilt and getting sewn in place.

- a First, position the needle directly above where you want to begin your pattern.
- b Pull on the **top thread** so that it is tight and jog the needle up and down using the single stitch button on the display.

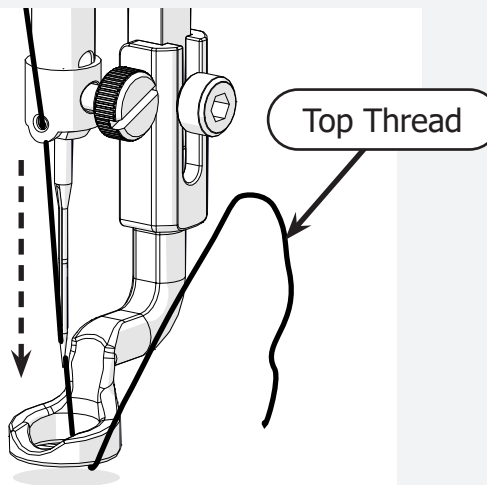

Getting Started (continued)

- c While still tightly holding the top thread, move the machine several inches to the side. Your top thread should pull a loop of **bobbin thread** through the **start point** to the top of the fabric.

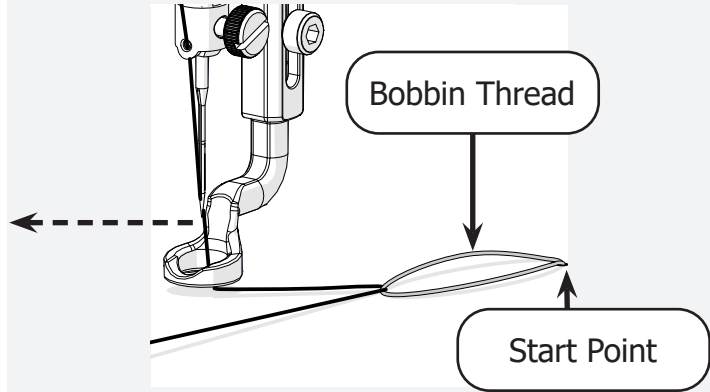

- d Pull on the loop of **bobbin thread** until the loose end of the thread comes up from underneath the fabric.

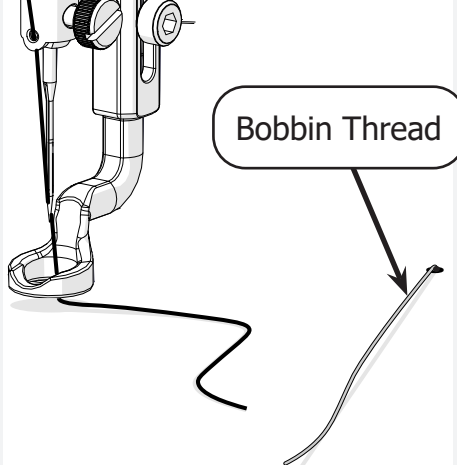

- e Pull on the bobbin thread while moving the machine back to the start point. This makes sure that there is no loose thread underneath the fabric.

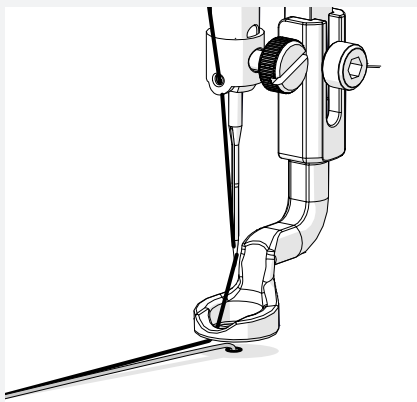

- 3 Secure your stitches and get quilting. Be sure to start as close as possible to the point where you pulled out the bobbin thread.

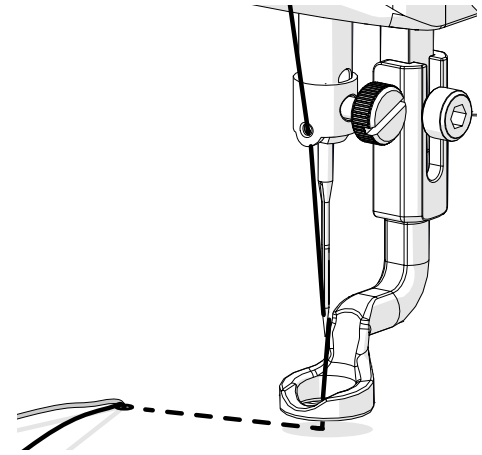

- 4 With fabric chalk or a marker, draw a simple pattern or write your name on the fabric and then stitch over it to practice.

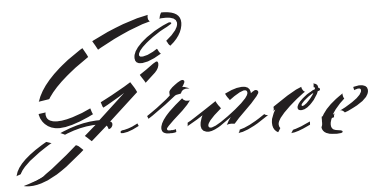
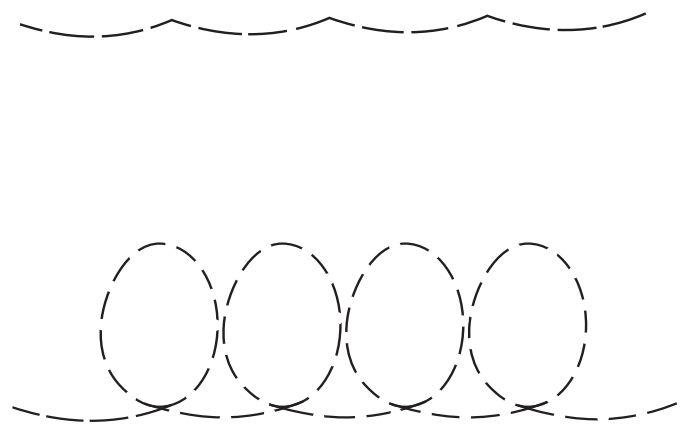

- 5 Complete the pattern by making a tie-off stitch. Use the single stitch button to make a few small stitches very close together.



- 6 To pull up the bobbin thread after making a tie-off, take the following steps:

- a Move the machine away from the tie-off stitch.

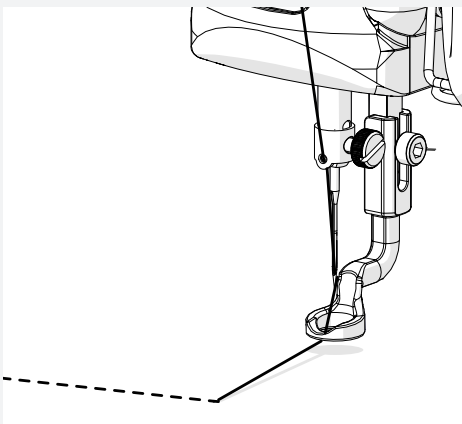

- b Hold the thread to make a loop and return the machine to the tie-off stitch.

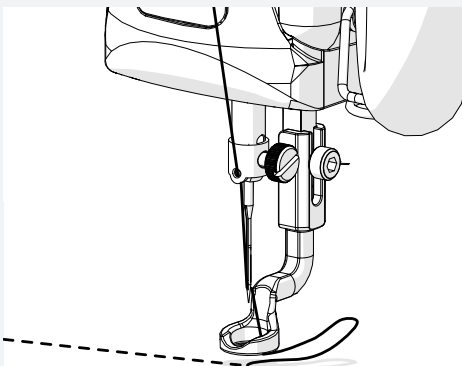

- c Make a single stitch over the tie-off.

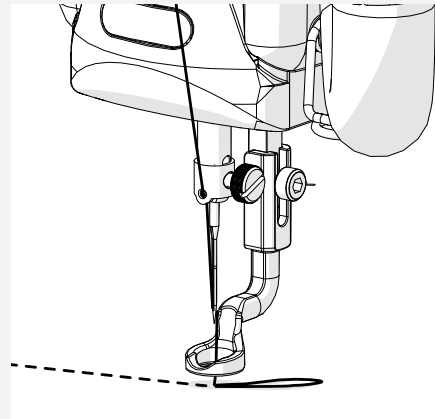

- d Hold the loop and move the machine away from the tie-off again.

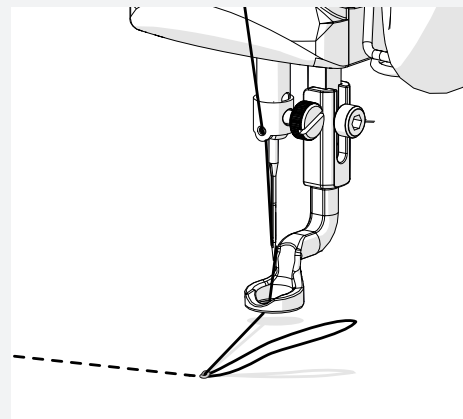

- e Keep moving away from the tie-off until a loop of bobbin thread is pulled up above the fabric. Cut all threads close to the tie-off.

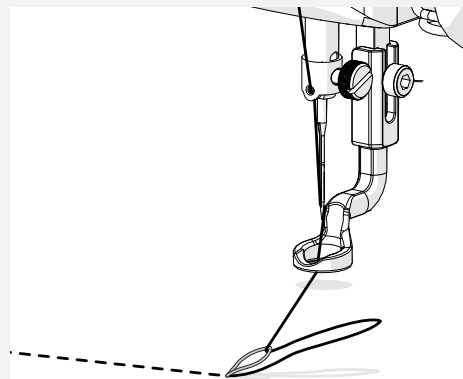

- 7 You may now cut the thread tails from the beginning of the pattern.

Practice! Keep trying different stitches until you feel comfortable with how your machine feels and moves. You can always attach a new piece of practice fabric if you need to.

Congratulations! Now that you have practiced and gotten used to the basic settings and movements of your machine, you are ready to begin your quilting journey.

Good luck, and thank you again for choosing The Grace Company to help with your quilting needs.

Maintaining the Machine

This section of the manual covers important machine maintenance and care procedures.

Preparing the Oil Bottle	page 72
Oiling and Cleaning	page 73
Changing the Needle	page 76
Adjusting the Hopping Foot	page 78
Reinstalling the Needle Plate.....	page 83
Re-assembling the Thread Tensioner	page 85

Preparing the Oil Bottle

Parts & Tools Needed:

Oil Bottle

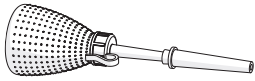

Scissors

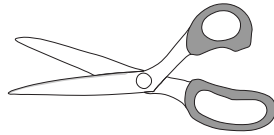

Power Cord/Oil Bottle
Box

(Not included)

Instructions

Take the following steps to prepare the oil bottle for use in oiling the machine.

- 1 Snip off about 1/4th of an inch from the tip of the plastic lid with a pair of scissors.

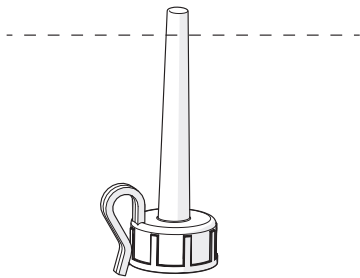

- 2 Place the applicator needle onto the top of the cap.

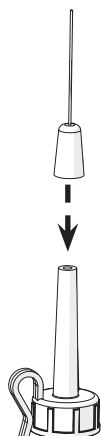

- 3 Peel the safety foil off the opening of the oil bottle.

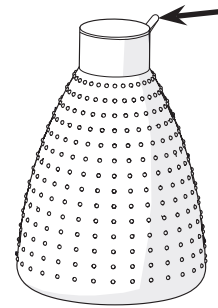

- 4 Carefully screw the lid onto the oil bottle.

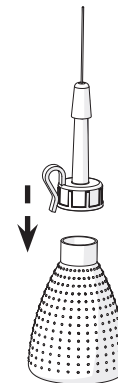

- 5 Hold bottle upside down and squeeze gently to apply oil. When not in use, cover the applicator needle with the safety cap.

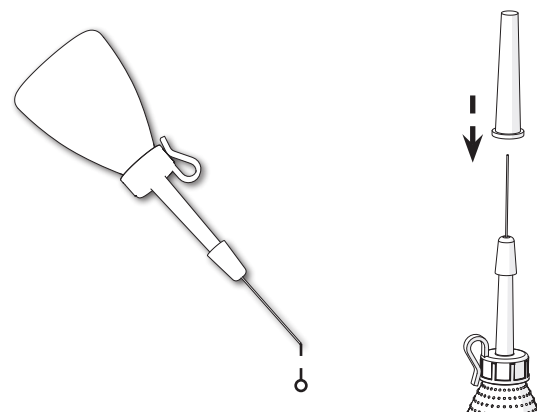

Oiling and Cleaning

Parts & Tools Needed:

Oil Bottle



Lint Brush (Tools Box)

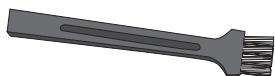

- Compressed Air Can (optional; not included)

Instructions

Oil and Clean:

Machine	<ul style="list-style-type: none"> • At the start of a new project • After 20 hours of use • After sitting without use for more than 30 days
Hook Assembly	<ul style="list-style-type: none"> • Every other bobbin change

Tip: The “Hours” counter on the Projects screen can be used to track hours of quilting time (see page 66).

Take the following steps to clean and oil the machine:

- 1 Power off the machine.
- 2 Set the **large thread tensioner** to “1” to expose the tensioner discs. Use the lint brush or a can of compressed air to clear away lint and thread remnants.

Note: Lint build-up between the tensioner discs can prevent proper thread tensioning.

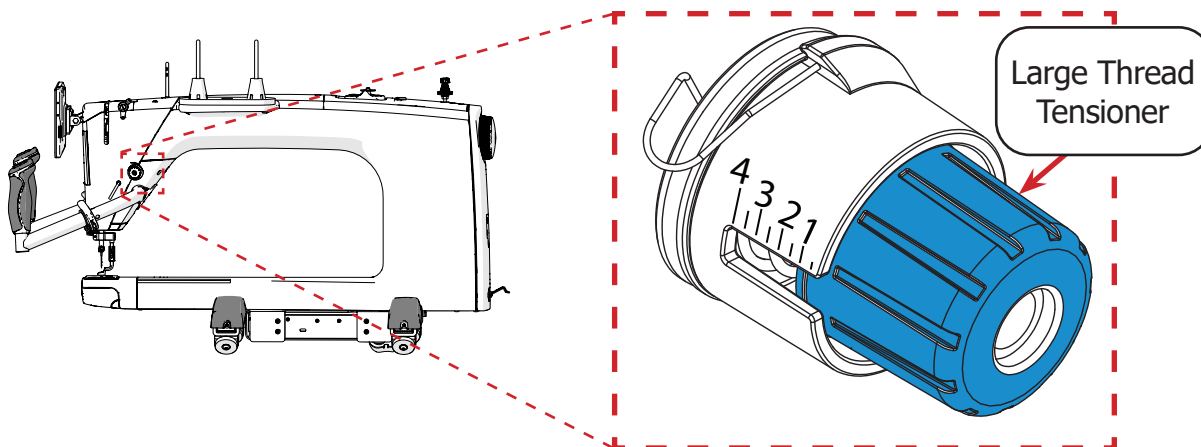

Part Four | Maintaining the Machine

Oiling and Cleaning (continued)

- 3 Clear debris from the spring and discs of the **small thread tensioner**.

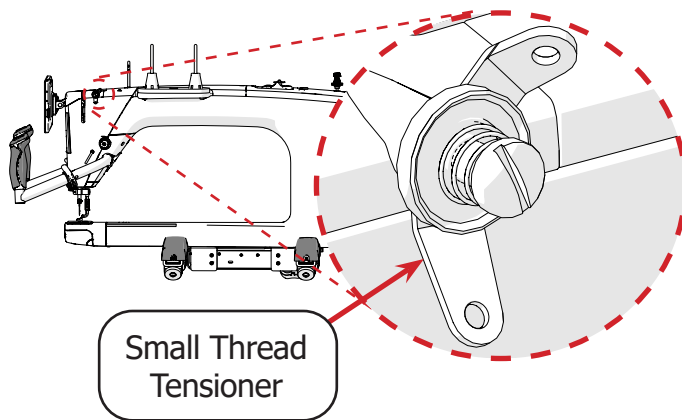

- 4 Pull the **release lever** (shown in blue) on the bobbin case to remove it from the hook assembly. If the case won't release, raise the needle with the hand wheel at the rear of the machine.

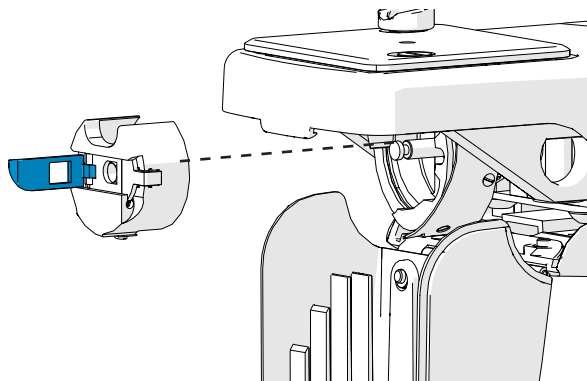

- 5 Set the bobbin aside. Clean the bobbin case with the lint brush or compressed air. Be sure to clean the area under the **bobbin tension thread arm**.

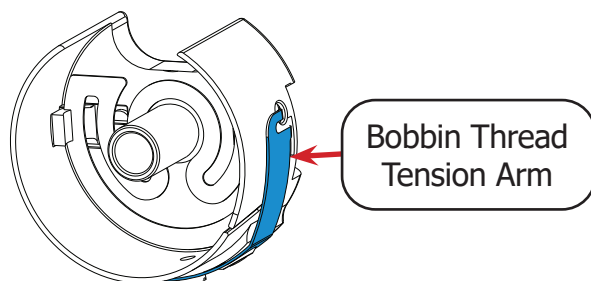

- 6 In and around the **hook assembly**, clear away any lint, cloth, and thread remnants.

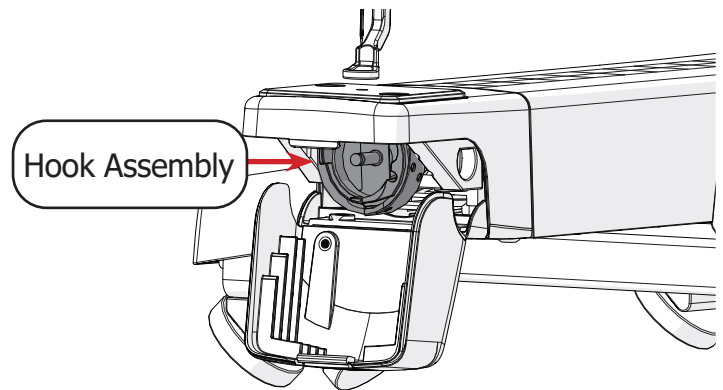

- 7 Rotate the **hand wheel** until the needle is halfway down. This will put the hook in the best position for oiling.

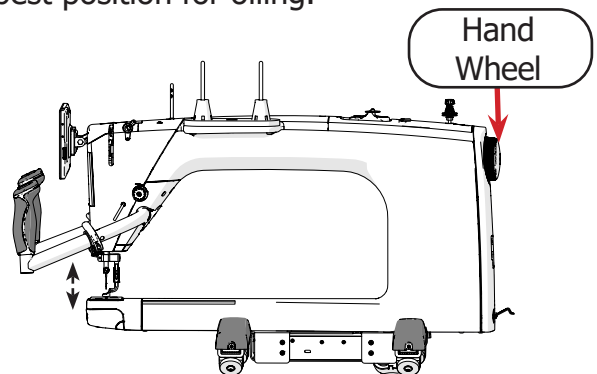

- 8 Place 1-2 drops of oil into the hook assembly between the **inner part** (shown in gray) and **outer part** (shown in blue).

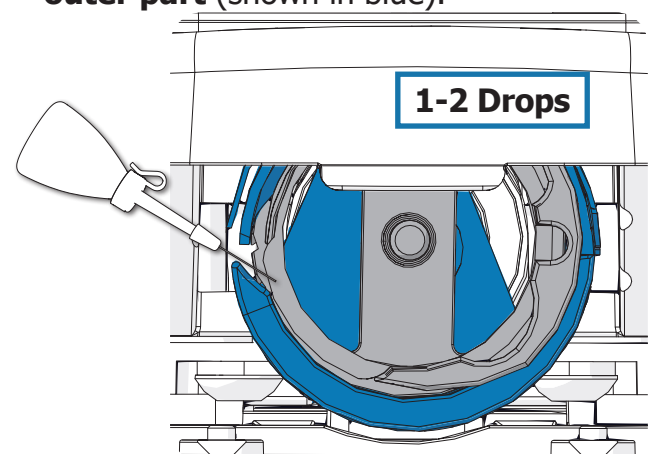

- 9 Unplug the display from the port on the machine.

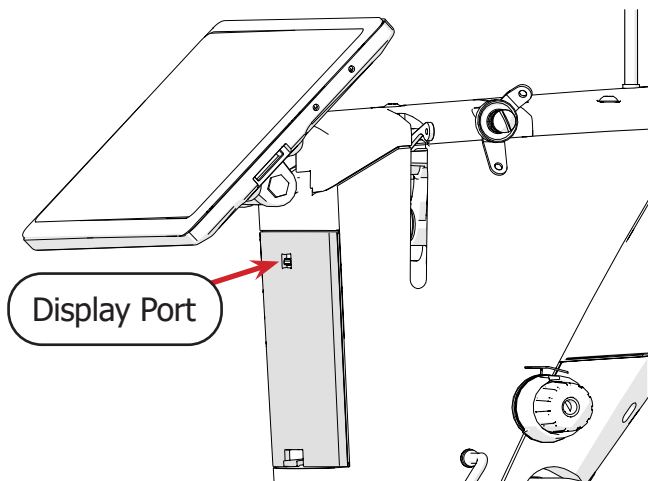

- 10 Pull the tab on the display board cover to remove it from the machine.

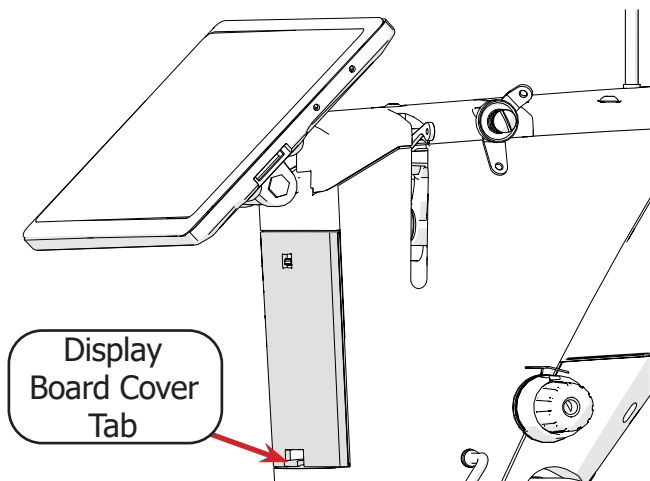

- 11 Place 1-2 drops of oil on the needle bar. Then replace the display board cover and plug the display back into the port.

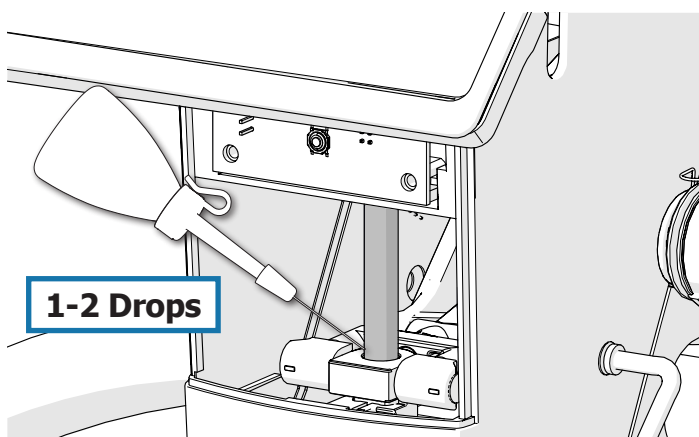

- 12 Power up the machine. Run the machine in manual or cruise stitching modes without a bobbin installed for about 10 seconds. This will distribute the oil in the hook assembly without getting oil on your bobbin thread.

- 13 Reload the bobbin case and return it to the machine (for detailed instructions on tensioning the bobbin case, see page 34). Close the hook assembly cover.

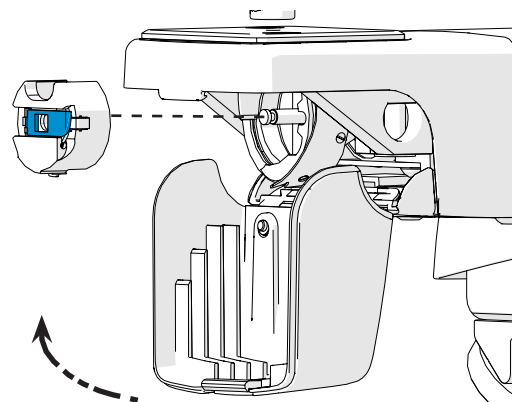

- 14 Wipe down the **needle bar** regularly to prevent oil from accumulating and dripping onto your quilt.

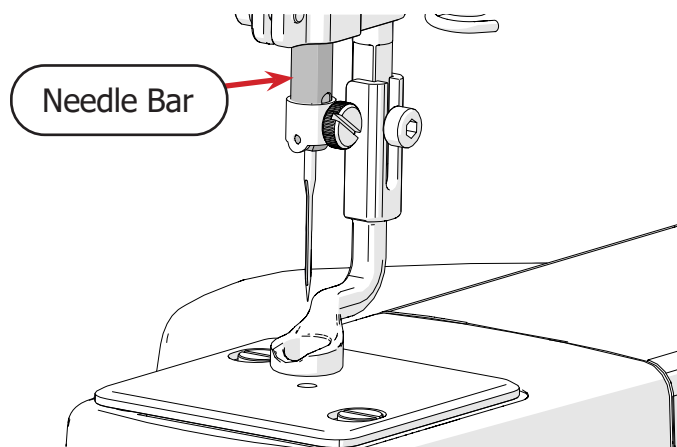

Changing the Needle

For information on selecting a needle, see page 101.

Parts & Tools Needed:

Needle



Needle Magnet

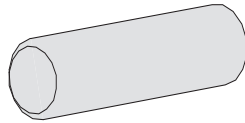

Instructions

A broken, bent, or burred needle may break thread, damage fabric, or even damage the machine. Always check that the needle is in good repair before starting a new project, and replace the needle after eight hours of use.

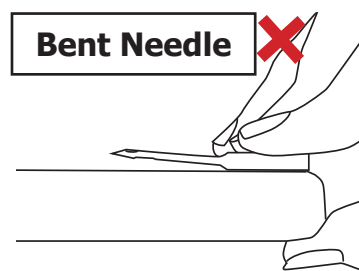
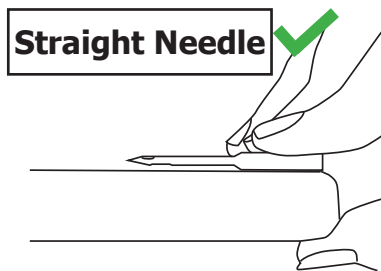

To avoid damage to the machine, please choose an approved needle style from the list below:

- DPx5 MR
- 134 MR
- 1955 MR

To change the needle, take the following steps:

- 1 Power off the machine.
- 2 With the **hand wheel**, raise the needle so it clears the hoop part of the hopping foot.
- 3 Loosen the **needle thumb screw** and pull down the needle. If needed, use a flat-head screwdriver.

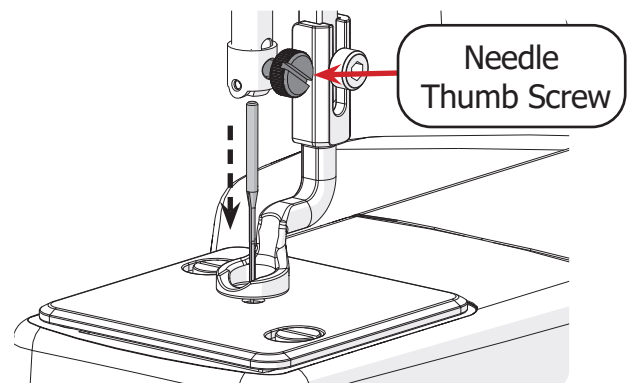
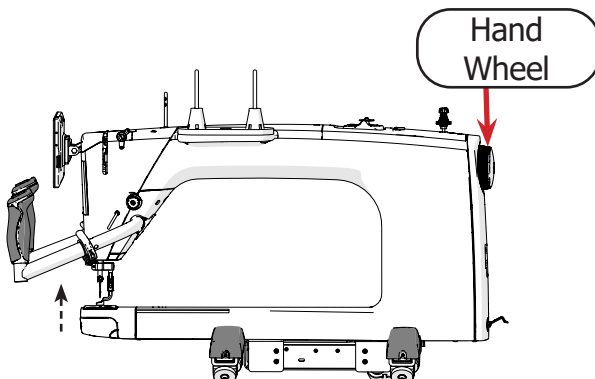

- 4 Insert the new **needle** all the way into the needle bar. Check the **needle bar sight hole** above the thumb screw to make sure the needle is inserted all the way.

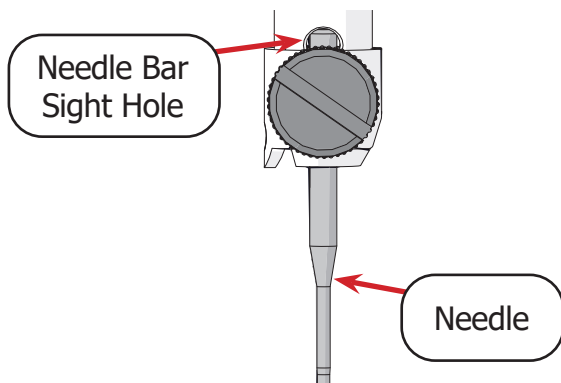

- 5 The **scarf**, a cut-out on the back of the needle, should face the throat of the machine. Place the **needle magnet** on the opposite side of the scarf.

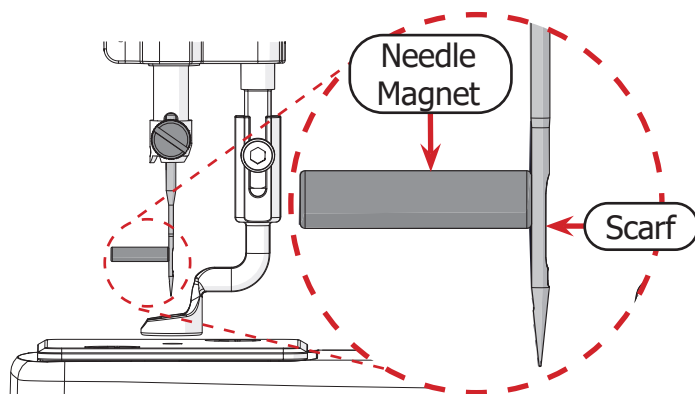

- 6 Use the needle magnet as a visual guide. Twist the needle until the magnet points as straight out from the machine as possible. **Note:** Do not attempt to adjust the needle by moving the magnet directly.

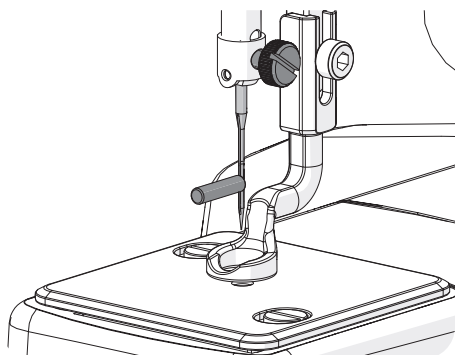

- 7 Hand-tighten the thumb screw. Do not over-tighten if using the flat-head screwdriver.

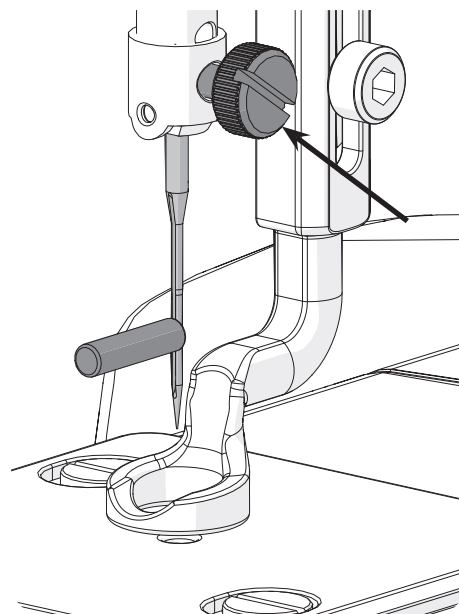

Adjusting the Hopping Foot

Parts & Tools Needed:

T-handle Allen
Wrench 3 mm

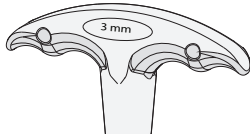

Hopping Foot
Height Tool



Height Adjustment

When quilting with thick fabric or batting layers, the hopping foot may be pressing down on the quilt too tightly and begin to drag. Alternatively, if the hopping foot is set too high, skipped stitches can result. The hopping foot can be raised or lowered to correct these problems. To adjust the hopping foot height, take the following steps:

- 1 With the **hand wheel**, raise the needle so it clears the hoop part of the hopping foot.

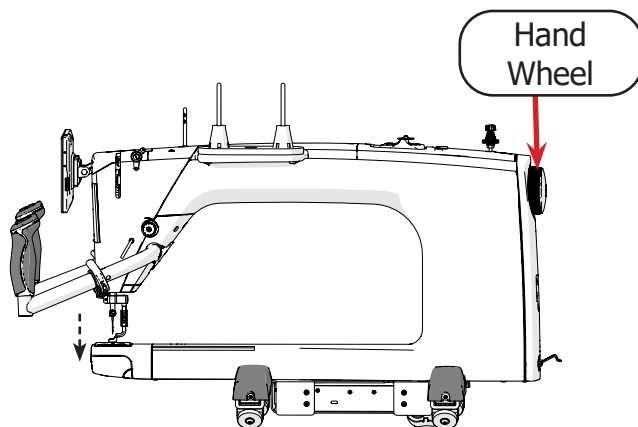

- 2 With the 3 mm Allen wrench, loosen the **hopping foot screw** that holds the hopping foot to the **hopping foot collar**.

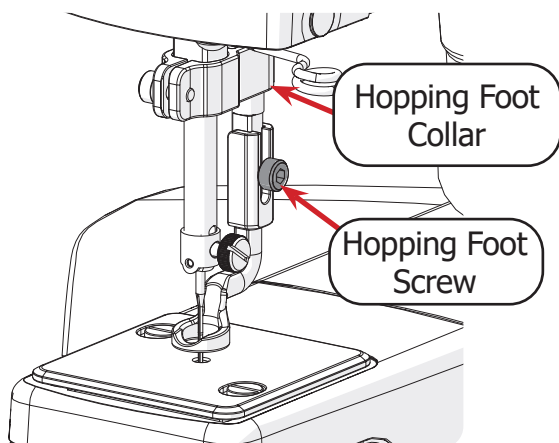

- 3 Slide the **hopping foot height tool** underneath the **hopping foot** so that the needle slides into the height tool groove.

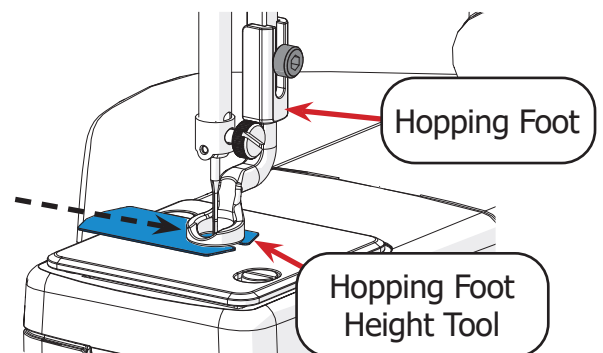

Note: The height tool prepares the machine for standard sized quilt batting and two layers of fabric. For thicker quilts, stack sheets of printing paper over the gauge to increase room underneath the hopping foot.

- 4 Re-tighten the **hopping foot screw**.

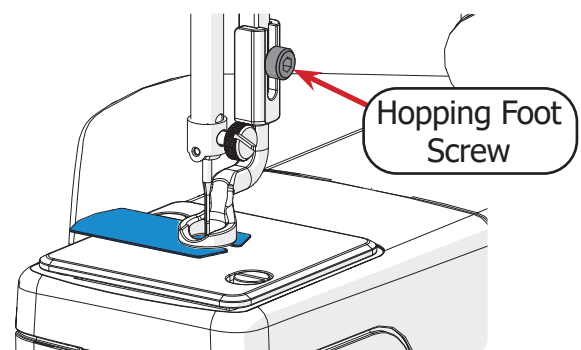

Rotation Instructions

The hopping foot can be rotated to improve line of sight. To rotate the hopping foot, please take the following steps.

- 1 Power off the machine.
- 2 Rotate the **hand wheel** to lift the needle to the highest position.

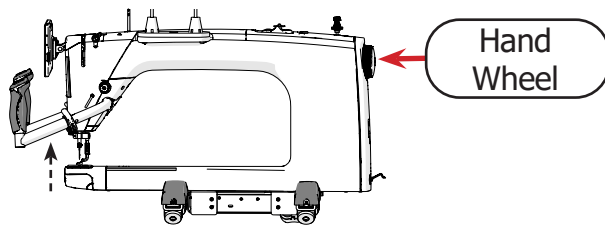

- 3 Use the 3 mm Allen wrench to remove the **screw** holding the hopping foot.

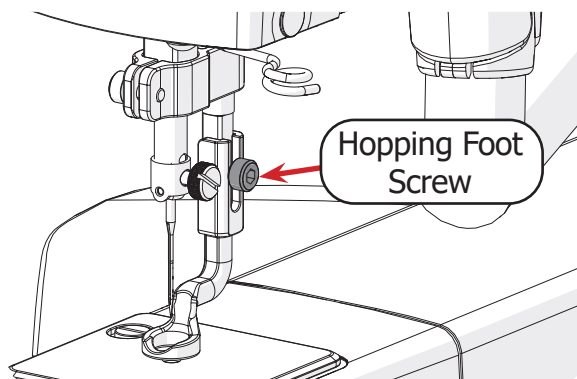

- 4 Slide the **hopping foot** from the presser bar.

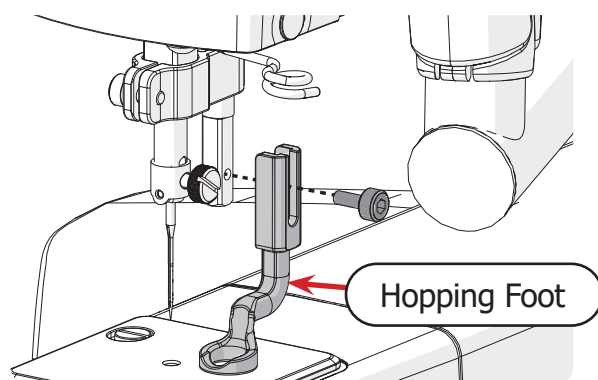

- 5 With the 3 mm Allen wrench, loosen the **collar screw** that holds the **hopping foot collar** to the presser bar.

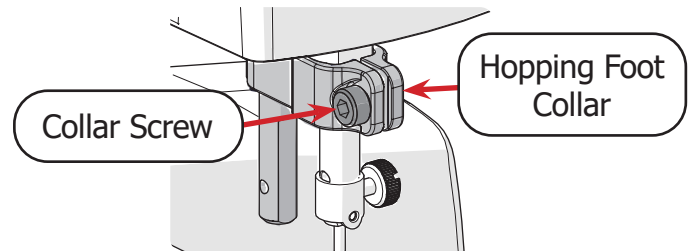

- 6 Drop the hopping foot collar below the presser bar and turn it to the desired position.

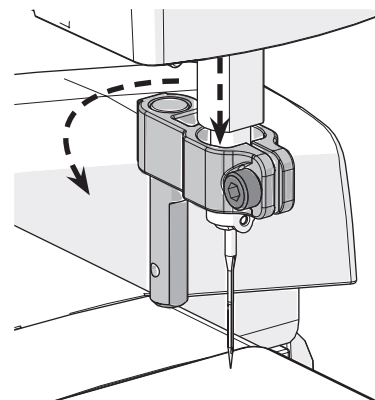

The hopping foot can be set to two positions:

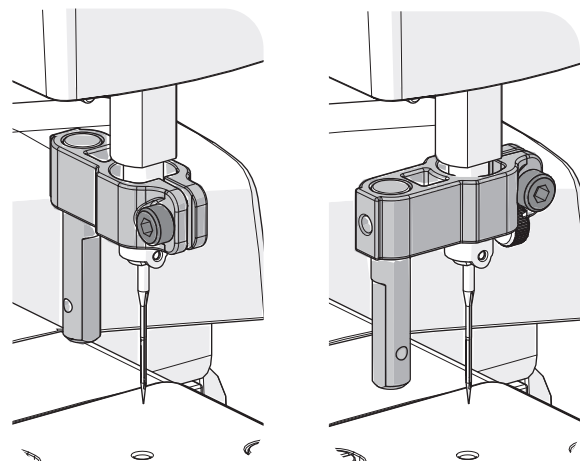

Part Four | Maintaining the Machine

Adjusting the Hopping Foot (continued)

- 7 Lift the hopping foot collar back up to the presser bar, and re-tighten the **collar screw**.

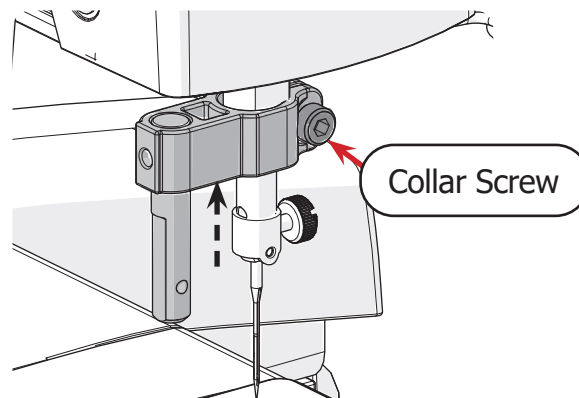

- 8 Slide the **hopping foot** into the collar and screw in place with the **hopping foot screw**.

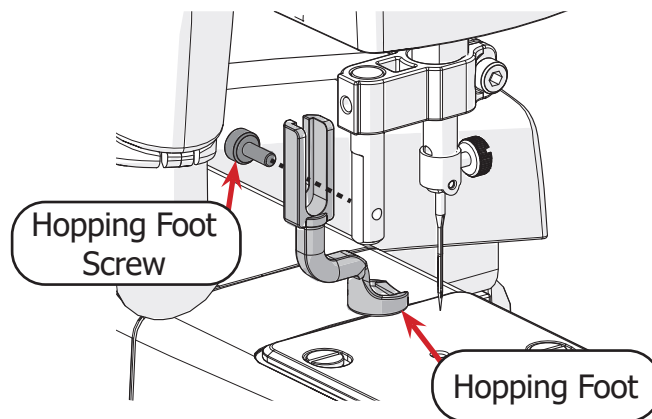

- 9 Set the hopping foot height (see page 78).

Removal Instructions

To remove the hopping foot for maintenance or to adjust the hopping foot angle, take the following steps:

- 1 Power off the machine.
- 2 With the **hand wheel**, raise the needle so it clears the hoop part of the hopping foot.
- 3 Use the 3 mm Allen wrench to remove the **hopping foot screw**.

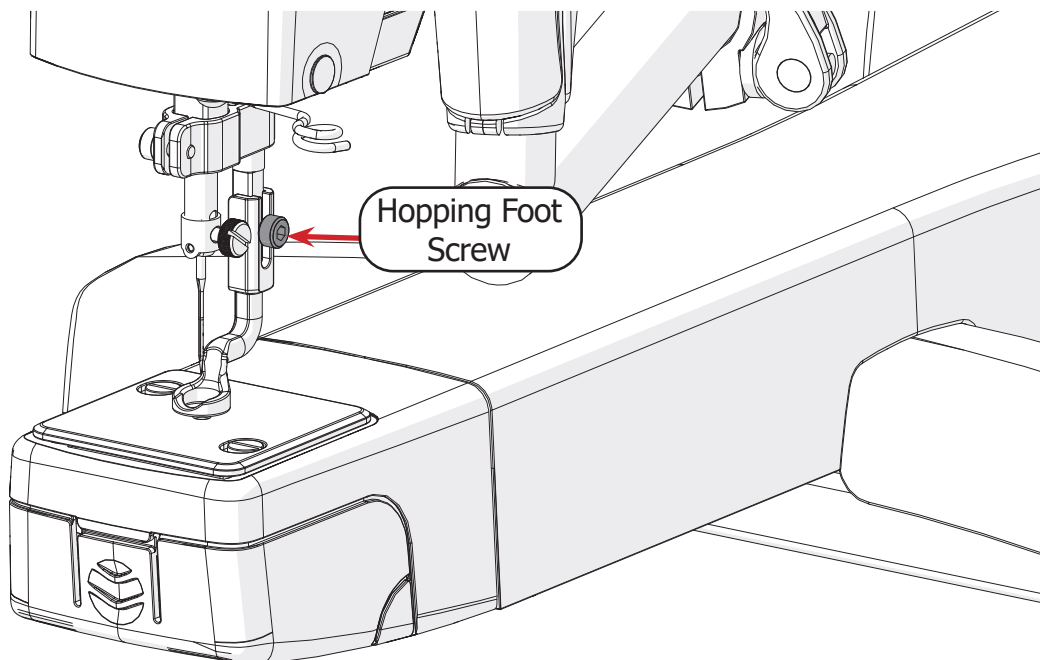

The **hopping foot** should now slide free from the presser bar.

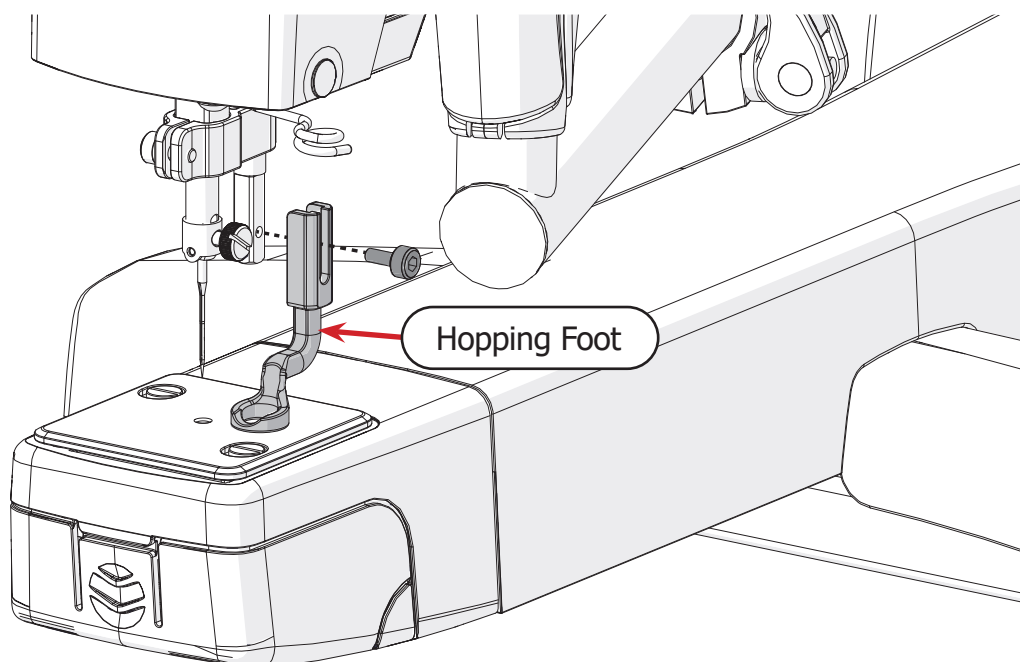

Installation Instructions

To install the hopping foot on your quilting machine, please take the following steps:

- 1 Power off the machine.
- 2 Slide the **hopping foot** to the slot in the **hopping foot collar**. Use the 3 mm Allen wrench and **hopping foot screw** to tighten in place.

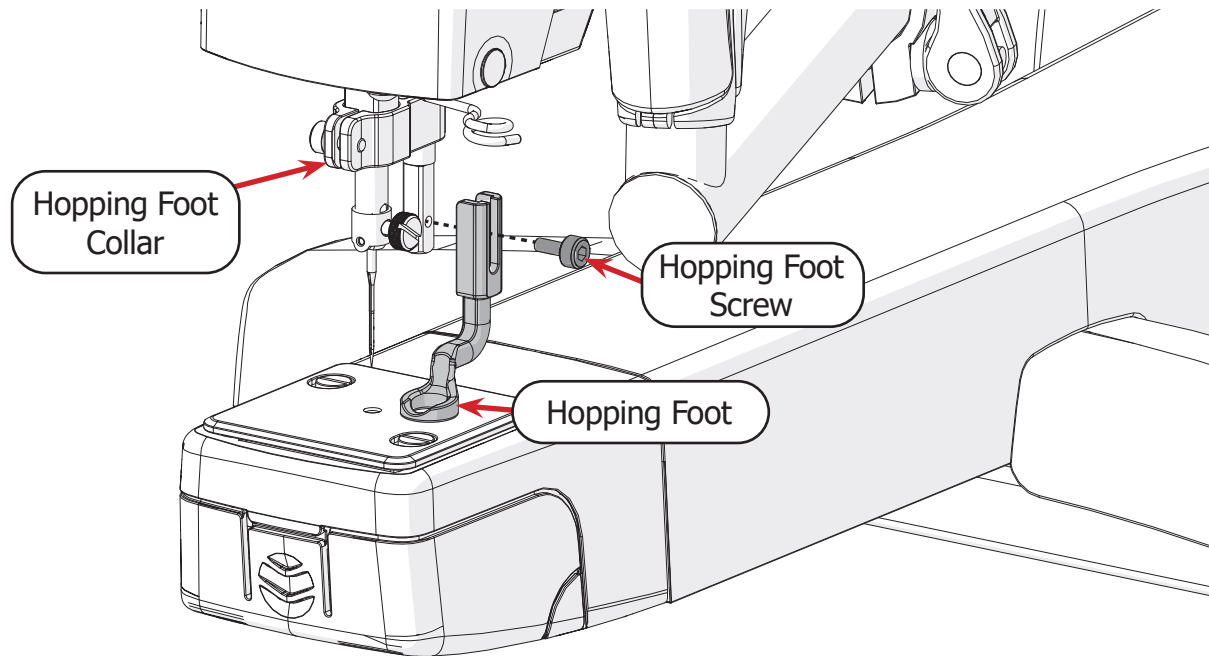

- 3 Adjust height as needed (see page 78).

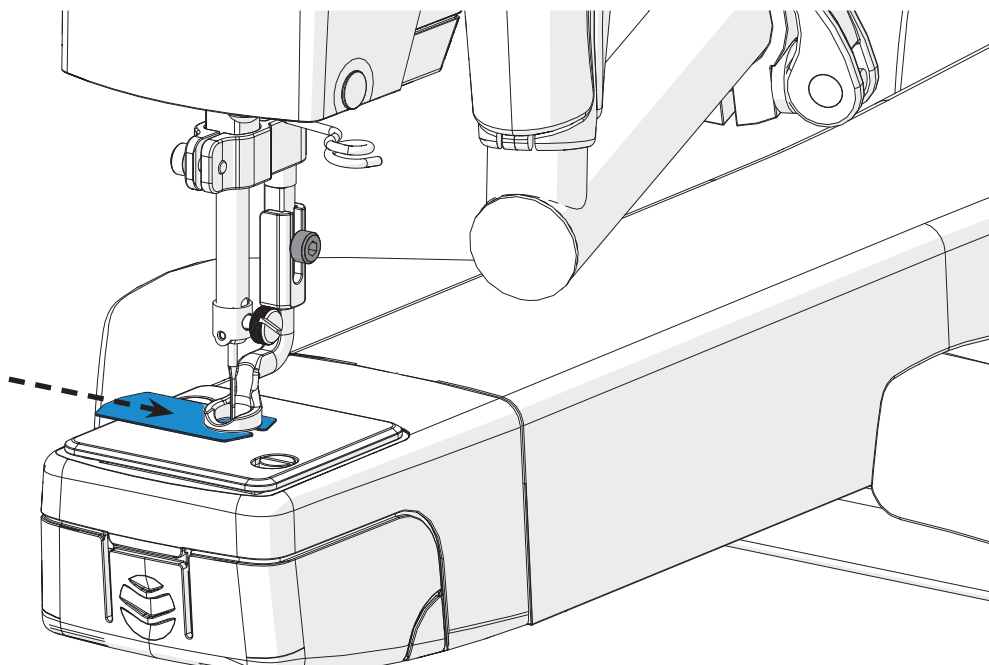

Reinstalling the Needle Plate

Parts & Tools Needed:

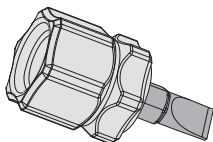

Flat-head Screwdriver

Removal Instructions

To remove the needle plate from the quilting machine, take the following steps:

- 1 Power off the machine and raise the needle to the highest position using the hand wheel.
- 2 Use the flat-head screwdriver to remove the two **needle plate screws**.

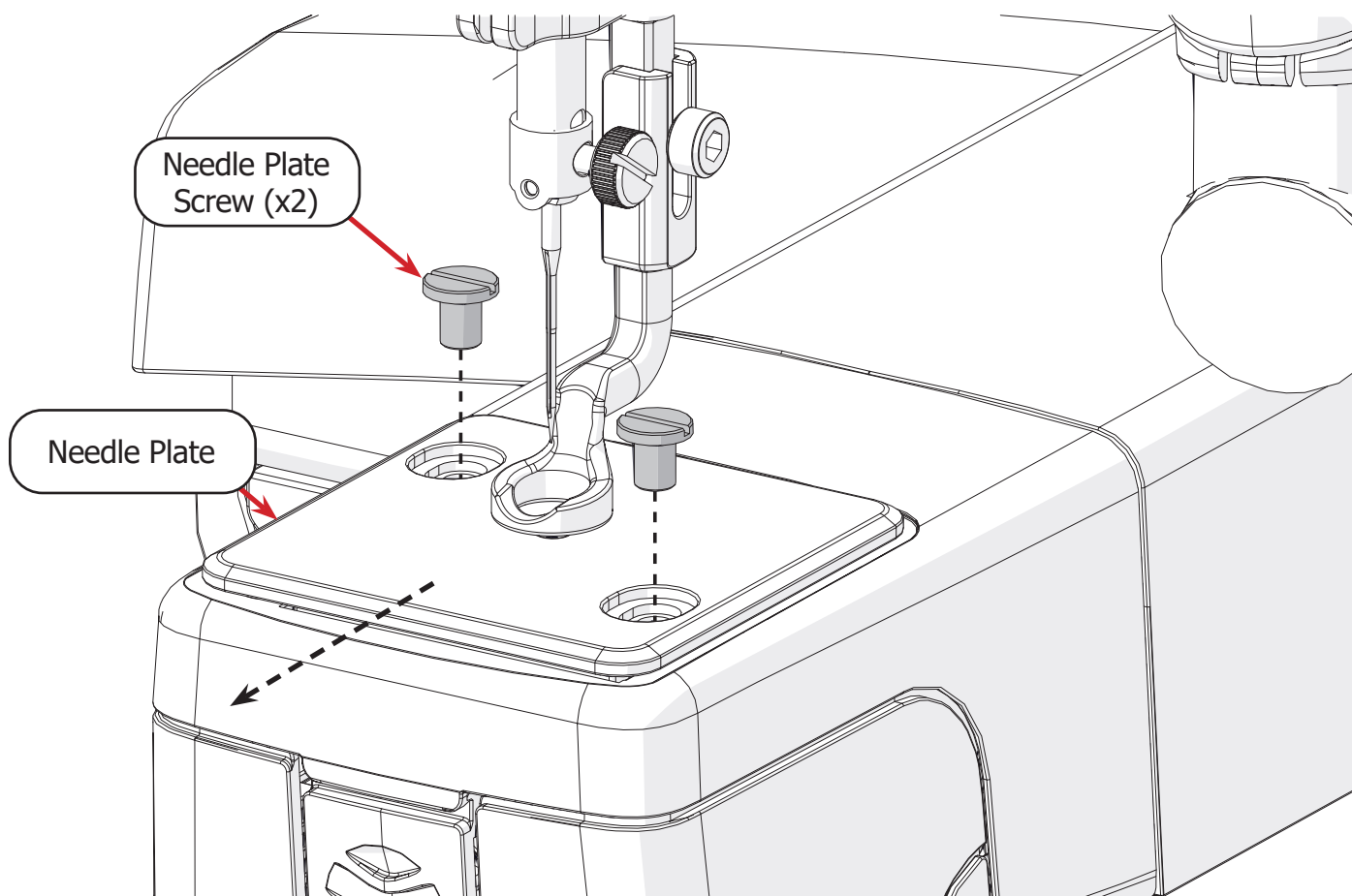

- 3 Slide the **needle plate** from the machine.

Installation Instructions

To install the needle plate onto the quilting machine, take the following steps:

- 1 Power off the machine. Raise the needle to the highest position using the **hand wheel**.

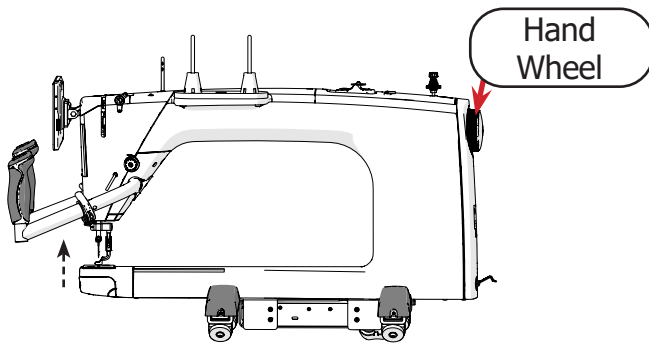

- 2 Align the screw holes on the **needle plate** with those on the machine.

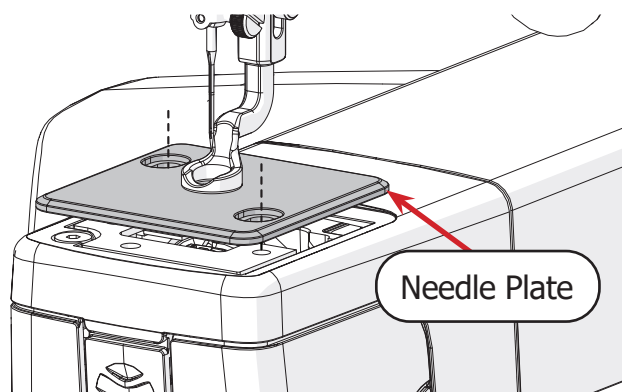

- 3 Slowly lower the needle with the hand wheel. The needle should slide into the center hole of the needle plate without contacting the plate.

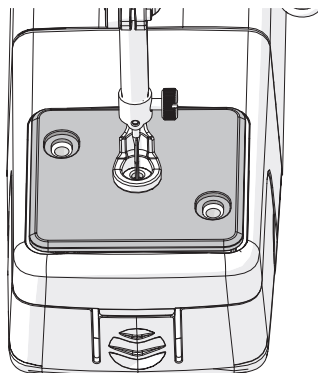

- 4 Place the two **needle plate screws** (shown in gray) into the plate. Make sure the needle plate is centered around the needle, and then tighten the screws with the flat-head screwdriver.

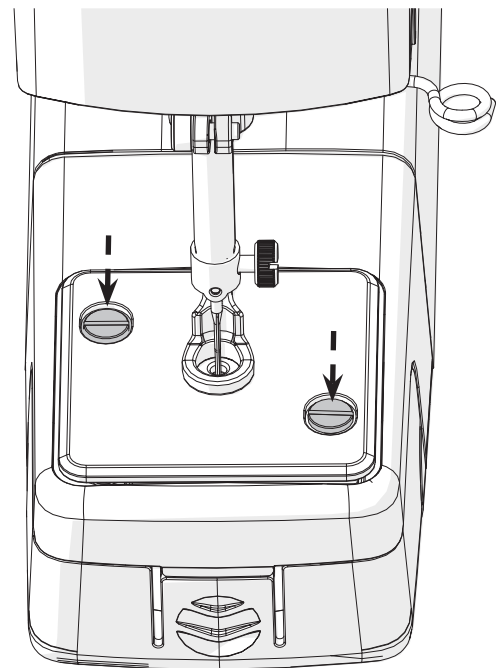

- 5 Reset the hopping foot height using the height gauge. See "Adjusting the Hopping Foot" on page 78 for instructions.

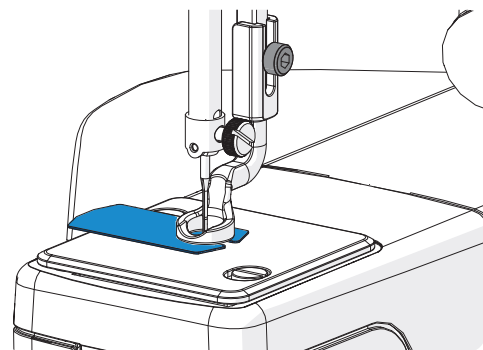

Re-assembling the Thread Tensioner

Instructions

If you over-loosen the large thread tensioner knob, the tensioner may come apart and need to be re-assembled.

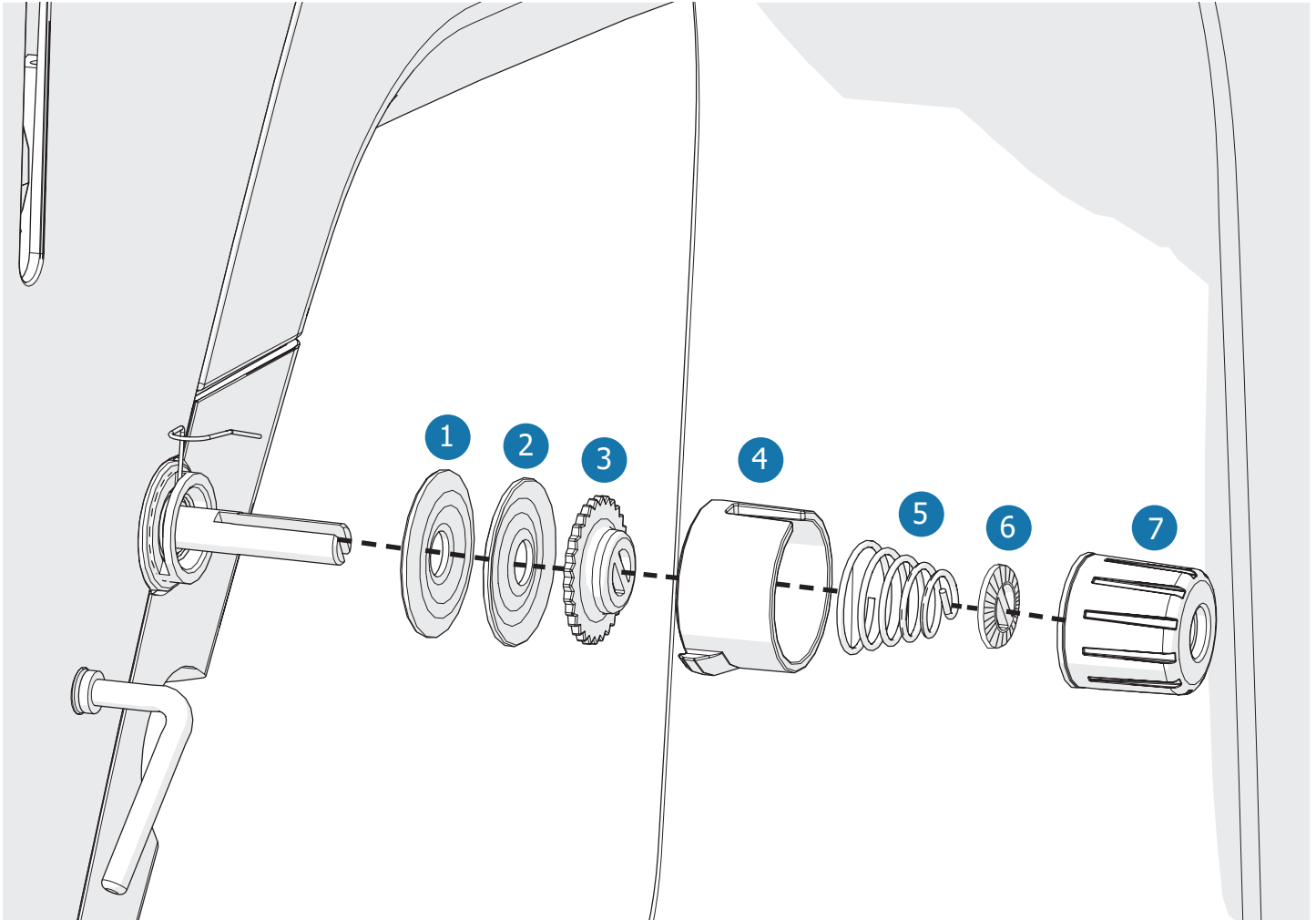

1 Tensioner Disc

3 Meter Key

5 Spring

7 Knob

2 Tensioner Disc

4 Meter

6 Keyed Washer

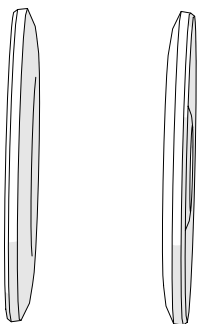

Note: Place the tension discs so the curved sides face each other.



Note: Install the keyed washer so the grooved side faces toward the knob.

Repairs and Diagnostics

The instructions in this section should only be taken at the direction of a Grace Company support technician. If you are experiencing problems with your machine, please contact our technical support team:

- **Phone:** (801) 485-6688
- **Email:** support@graceframe.com

Checking the Firmware	page 87
Troubleshooting Bobbin Wind.....	page 88
Replacing the Encoder Spring	page 90
Reinstalling the Hook Holder	page 93
Timing the Machine	page 96

This section of the manual covers replacing the encoder spring, installing the hook holder, timing the machine, and checking the firmware versions of the machine and display.

Checking the Firmware

The firmware versions for the machine and the display are found by pressing "System Info" from the bottom of the Settings menu (see page 44).



The following information and options display:

- **Display Version:** Shows the software version for the touch display.
- **Machine Firmware:** Shows the firmware version for the machine.
- **Date:** Shows the date when the machine firmware was last updated.
- **Update Button:** Checks to see if an SD card with an available software update has been inserted into the display. If it detects the update, it will update the display to the newest version.
- **OK Button:** Click to return to the Settings menu.

Troubleshooting Bobbin Wind

A quality bobbin wind is essential for a properly functioning machine and for setting your baseline thread tension. The thread on the bobbin should be smooth and evenly wound. The threads should be tightly packed together.

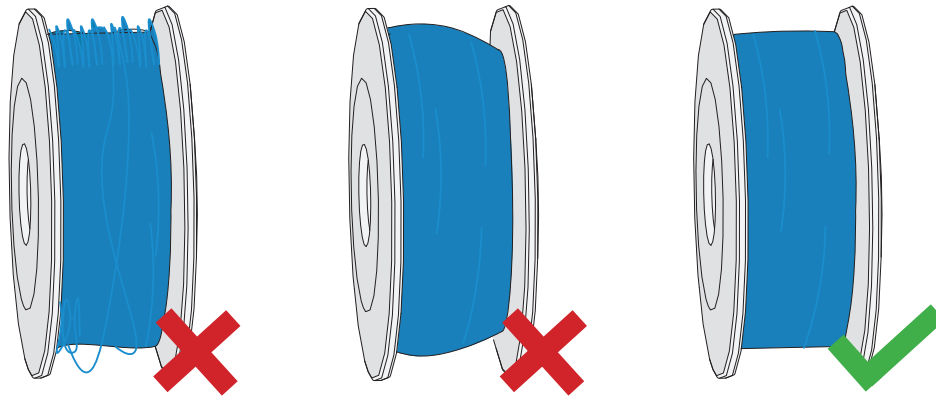

Bobbin Wound Too Loose

The tension of the bobbin wind is determined by the bobbin thread tensioner. Turn the knob one full rotation clockwise and re-test the bobbin wind. Repeat until the bobbin wind is tight and smooth.

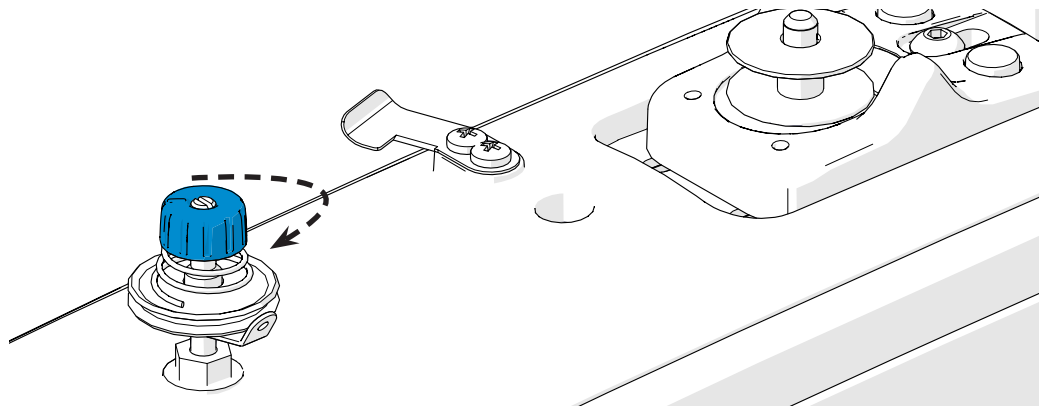

Bobbin is Filling to One Side

If the bobbin is filling to one side, the bobbin thread tensioner is positioned incorrectly and will need to be adjusted.

- 1 Determine the whether the bobbin is filling more toward the top or the bottom.



- 2 Unthread the bobbin thread tensioner. With a 7 mm wrench or needle-nose pliers, loosen the **nut** at the base of the tensioner.

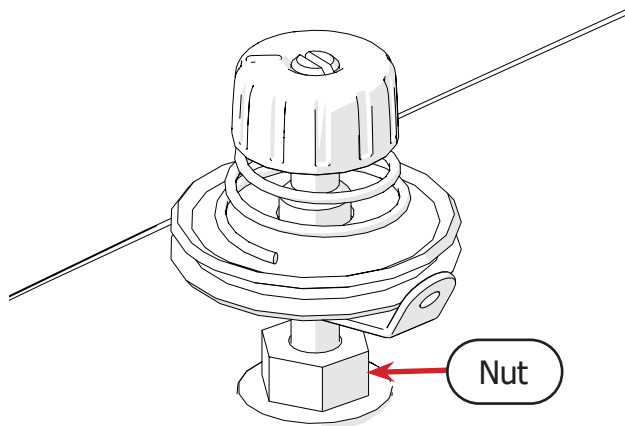

- 3 Turn the top part of the tensioner assembly (shown in blue) a full rotation to adjust the height of the tension discs.

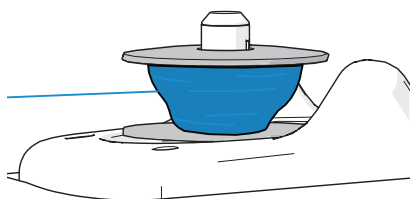

If the bobbin is filling more toward the top, turn the tensioner one full rotation clockwise and re-test.

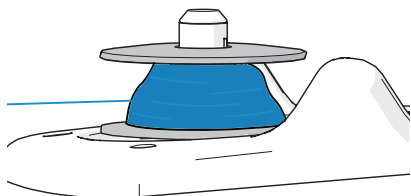

If the bobbin is filling more toward the bottom, turn the tensioner one full rotation counter-clockwise and re-test.

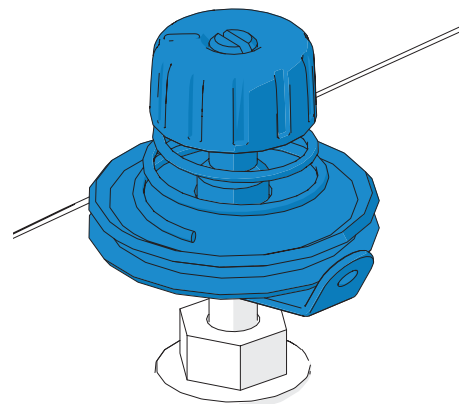

- 4 Once the bobbin is filling correctly, re-tighten the **nut**. Make sure the **thread guide** is on the correct side of the tensioner assembly.

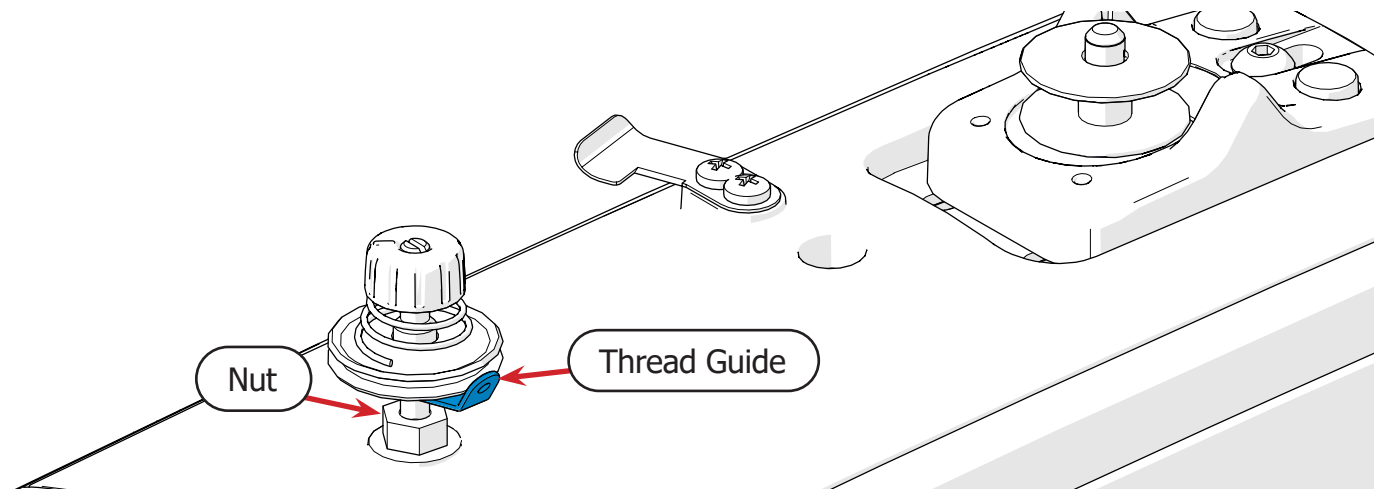

Replacing the Encoder Spring

Please speak to a Grace Company support technician before attempting these instructions.

Parts & Tools Needed:

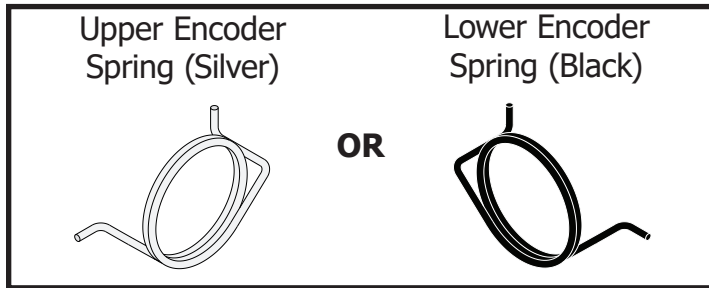

T-handle Allen Wrench 2.5 mm

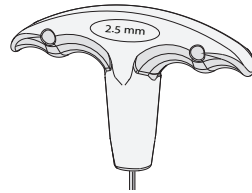

T-handle Allen Wrench 4 mm

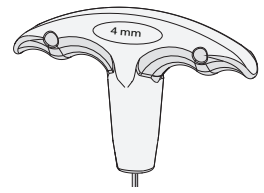

Instructions

If the encoder spring is over-tensioned, it may break and need to be replaced. To replace the encoder spring, take the following steps:

- 1 Determine the correct spring to use in the repair:



Upper Encoder: Attached to the wheel on the machine. Use the silver spring.



Lower Encoder: Attached to the wheel on the bottom carriage. Use the black spring.

- 2 Unplug the encoder cable from the machine.

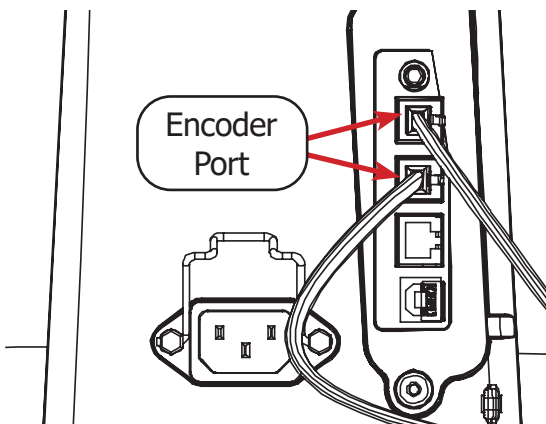

- 3 Loosen the **lock collar screw** with the 2.5 mm Allen Wrench until the **lock collar** (shown in blue) can twist freely.

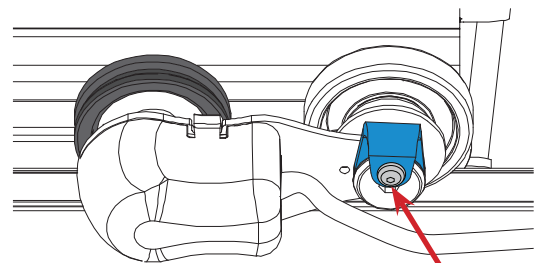

Lock Collar Screw

- 4 Use the 4mm Allen wrench to loosen the **encoder bolt** and remove the encoder and wheel.

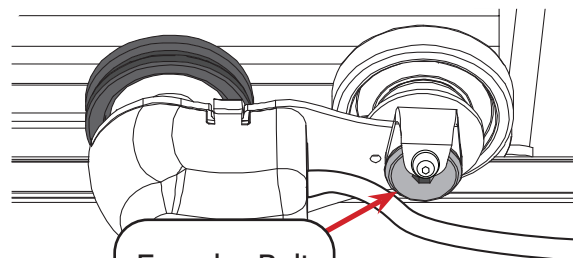

Encoder Bolt

- 5 Remove the **plastic stop**, **wheel spacer**, **washer**, broken **encoder spring**, and **shoulder spacer** from the encoder.

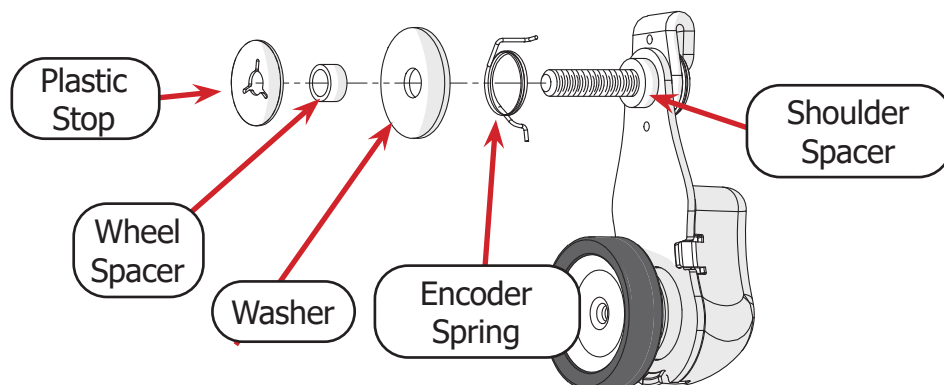

- 6 Pull on the **lock collar** to remove it from the encoder bolt.

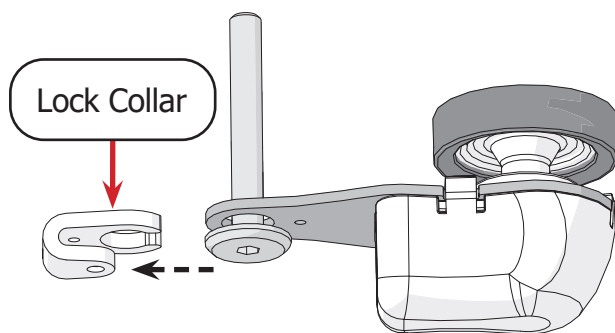

- 8 Place the **long arm** of the encoder spring arm into the hole on the encoder **lock collar**.

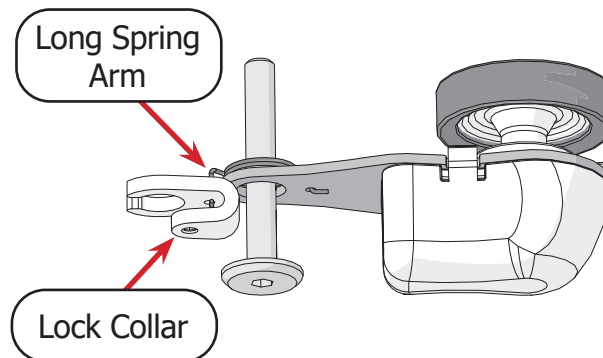

- 7 Place the replacement spring over the encoder bolt, and insert the **short arm** of the spring all the way through the hole on the encoder base.

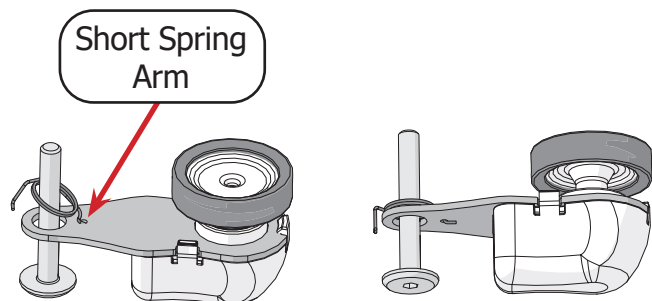

- 9 Without allowing the arm to slip out of the lock collar, rotate the collar until it wraps around the encoder bolt.

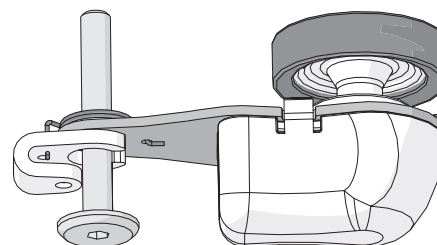

Replacing the Encoder Spring (continued)

- 10 Adjust the screw and lock collar so the head of the screw slides in between the lock collar.

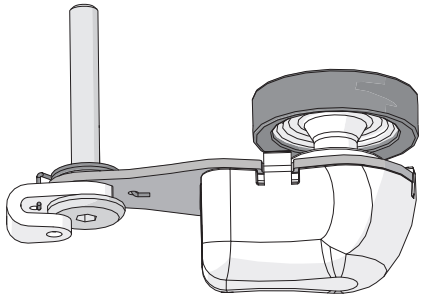

- 13 Complete the assembly instructions for the encoder you repaired.

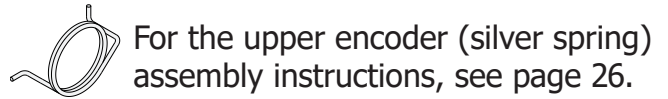

For the upper encoder (silver spring) assembly instructions, see page 26.

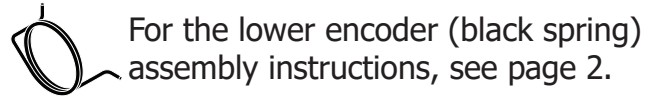

For the lower encoder (black spring) assembly instructions, see page 2.

- 11 Slide the **shoulder spacer** onto the screw with the thinner side toward the head of the bolt.

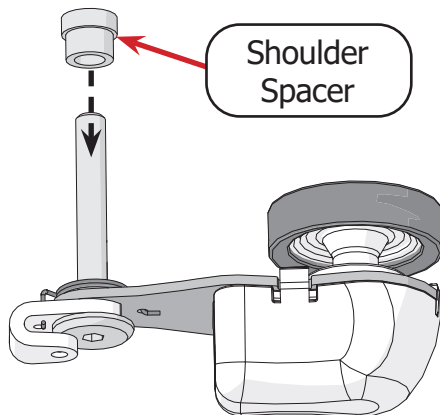

- 12 Next, place the **washer**, **wheel spacer**, and **plastic stop** onto the encoder bolt.

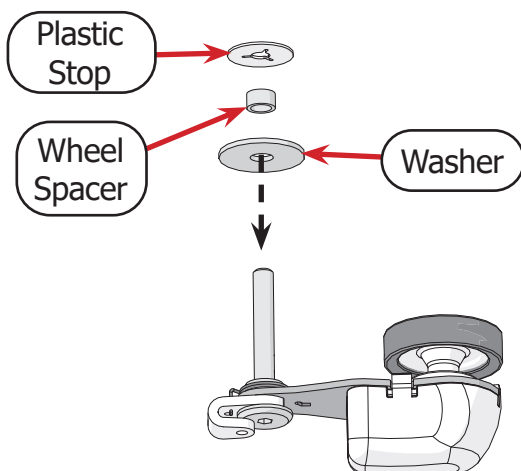

Reinstalling the Hook Holder

Please speak to a Grace Company support technician before attempting these instructions.

Parts & Tools Needed:

T-handle Allen
Wrench 3 mm

Flat-head Screwdriver

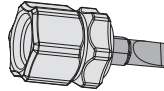
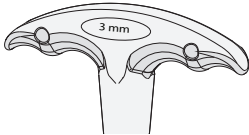

Removal Instructions

The hook holder keeps the hook assembly in place. The following procedure should only be attempted if determined necessary by a Grace Company support technician. If done incorrectly, major machine problems can result. Please call (800) 264-0644 before attempting this procedure.

- 1 Turn off the machine.
- 2 Rotate the **hand wheel** to raise the needle to the highest point.

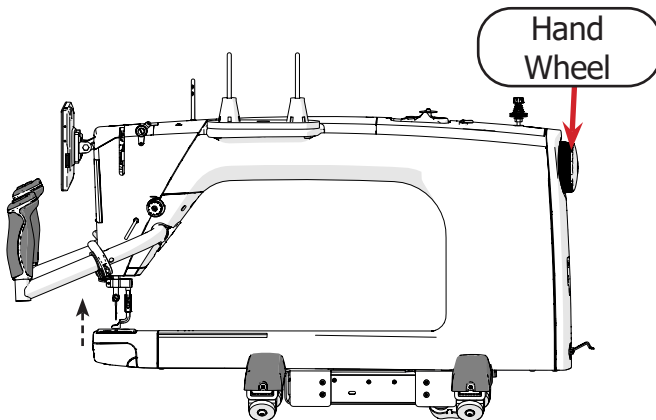

- 3 Press in on the hook assembly cover and down to open it.

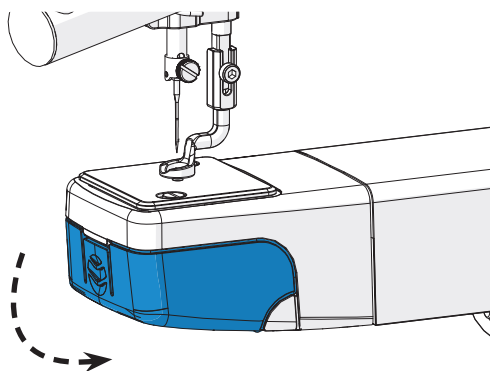

- 4 With the 3 mm Allen wrench, remove the **hook holder screw** (shown in gray) that attaches the hook holder to the machine.

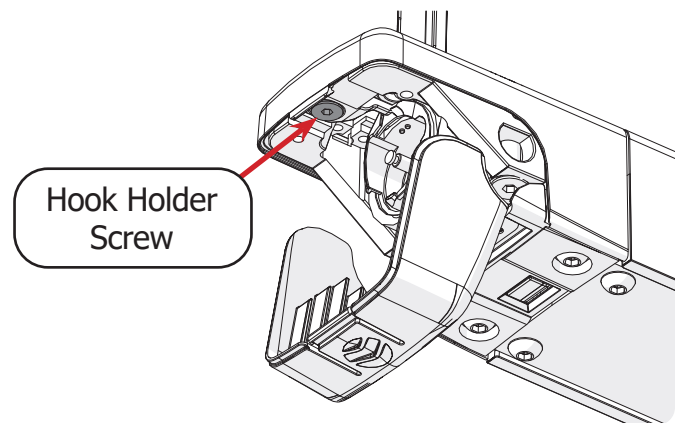

- 5 The **hook holder** will fall free of the machine.

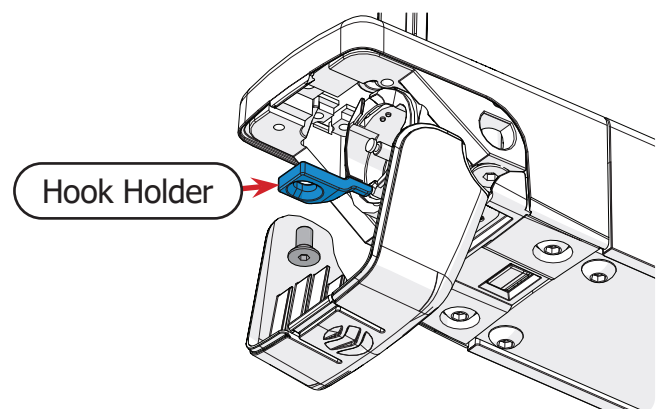

Installation Instructions

- 1 Turn off the machine.
- 2 Rotate the **hand wheel** to raise the needle to the highest point.

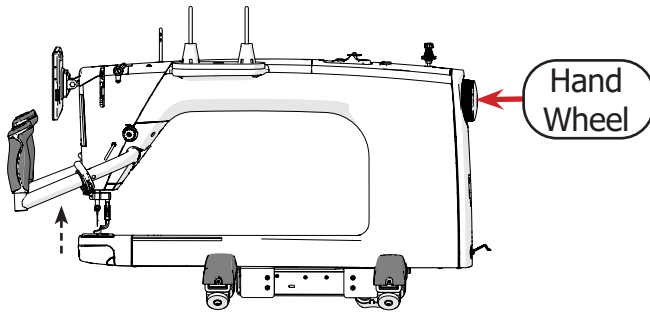

- 3 Remove the needle plate using the flat-head screwdriver (see page 83).

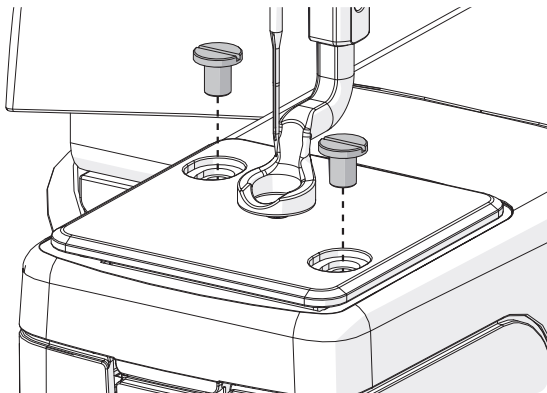

- 4 Remove the bobbin case from the hook assembly (see page 34).

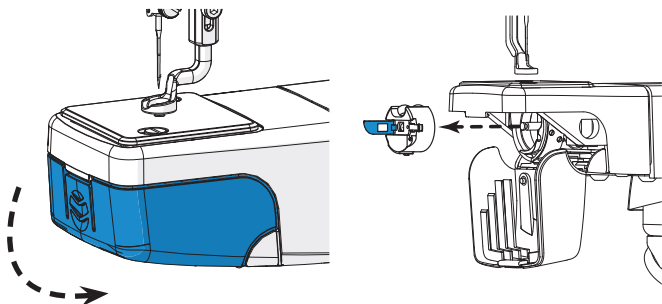

- 5 Turn the inside part of the **hook assembly** (shown in blue) so that the **positioning guide** is at the highest point.

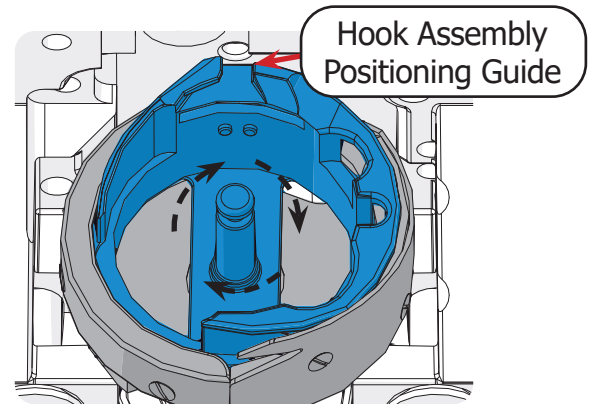

- 6 Slide the finger of the **hook holder** into the middle of the **hook assembly's positioning guide**.

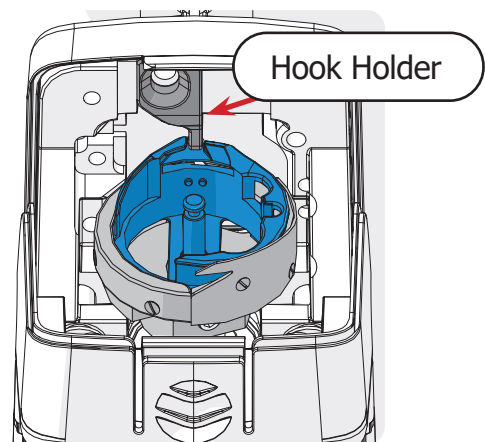

- 7 Attach loosely with the **hook holder screw**. Do not tighten.

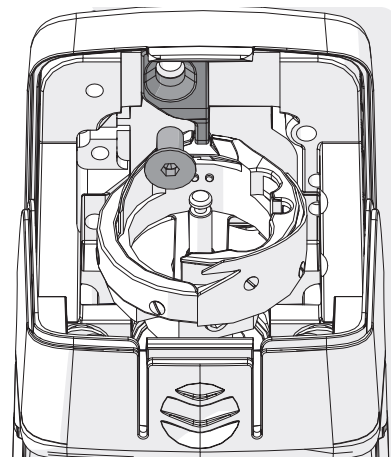

- 8 Align the **hook holder** with the inside edge of the **positioning guide**, as shown below.

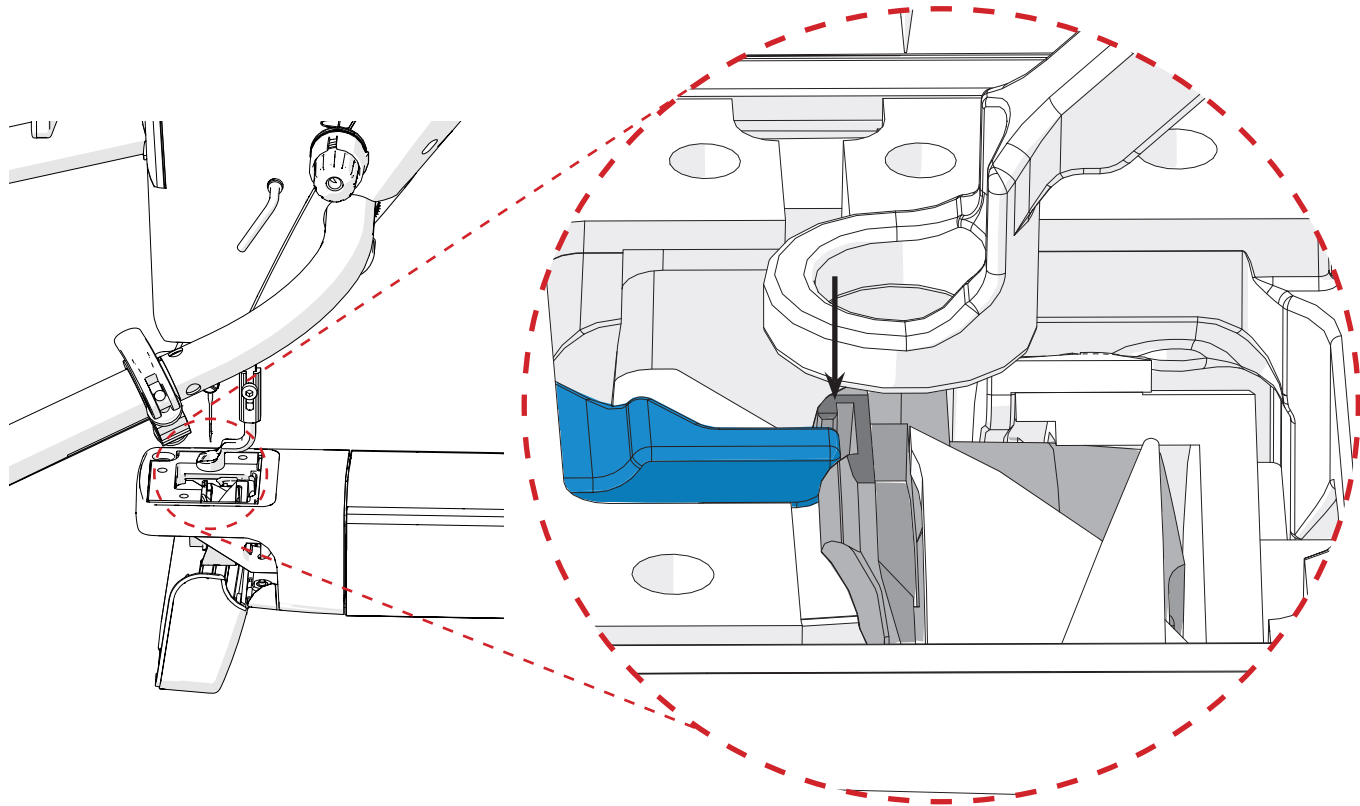

- 9 Tighten the hook holder screw to fasten the hook holder in place. The inside part of the hook assembly should no longer rotate freely by hand.

- 10 Re-install the needle plate. See page 83 for instructions.

Timing the Machine

Please speak to a Grace Company support technician before attempting these instructions.

Parts & Tools Needed:

Flat-head Screwdriver

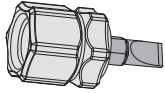

T-handle Allen Wrench 2 mm

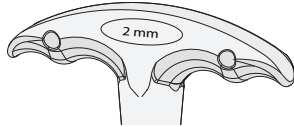

Timing Spacer Tool

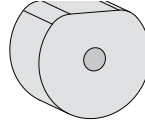

Instructions

Timing your machine aligns the needle and hook assembly so that they are in the correct places during the creation of a stitch. Improper timing can result in damage to the machine and needle, or make sewing impossible. Please consult with a Grace Company support technician before attempting to adjust the timing on your machine.

- 1 Turn off the machine.
- 2 Check that your **needle** is not bent or damaged, and that it is inserted all the way into the needle bar (see page 76).

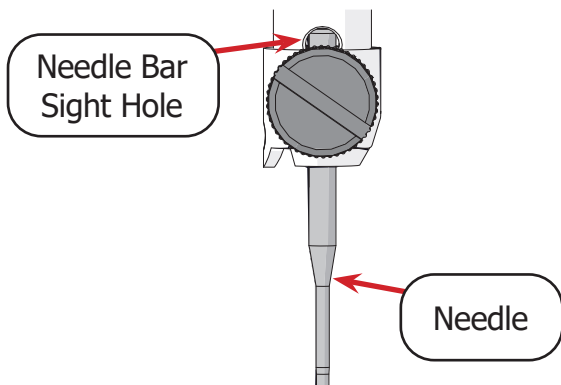

- 3 Remove the bobbin case from the hook assembly (see page 34).

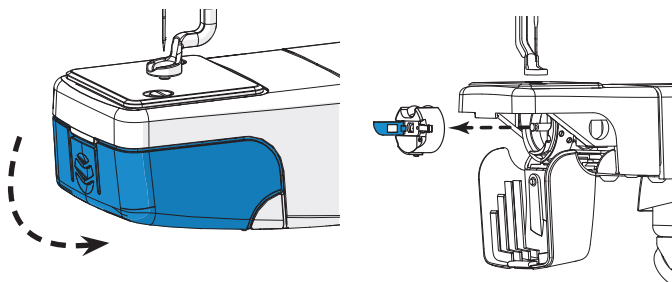

- 4 Remove the needle plate (see page 83).

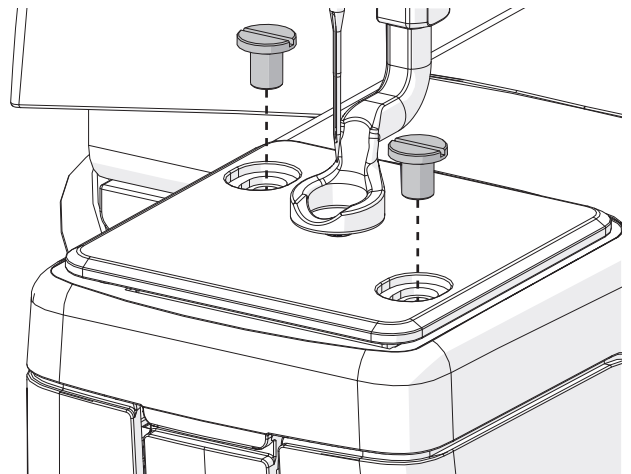

- 5 Look into the machine's **timing cut-out** and turn the hand wheel. The **hook assembly** will rotate.

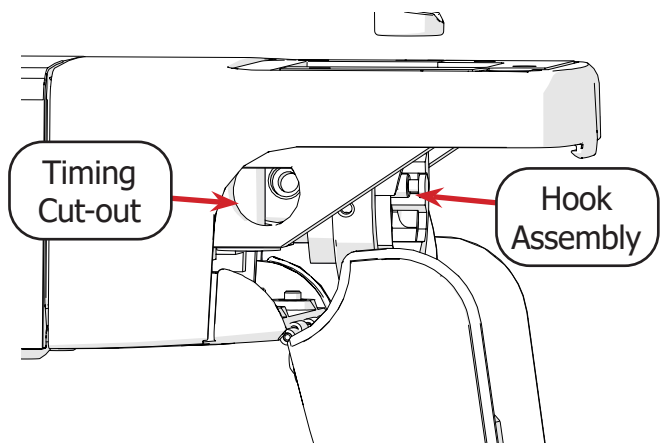

- 6 As each of the **3 set screws** aligns with the timing cut-out, loosen them with the 2 mm Allen wrench.

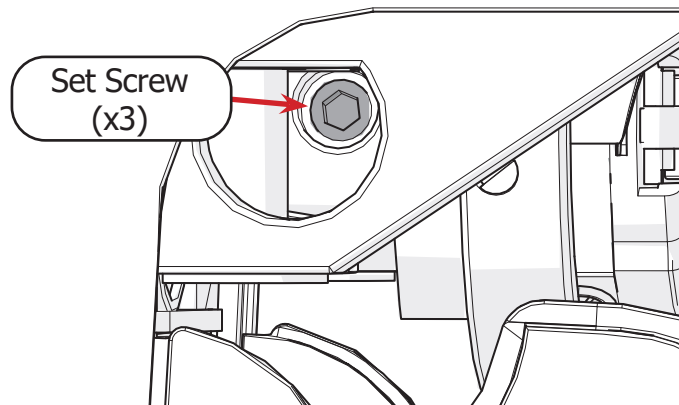

- 7 The **outside** part of the hook assembly (shown in blue) now rotates by hand. Turn the outside part of the hook assembly so that the **hook** is at the top.

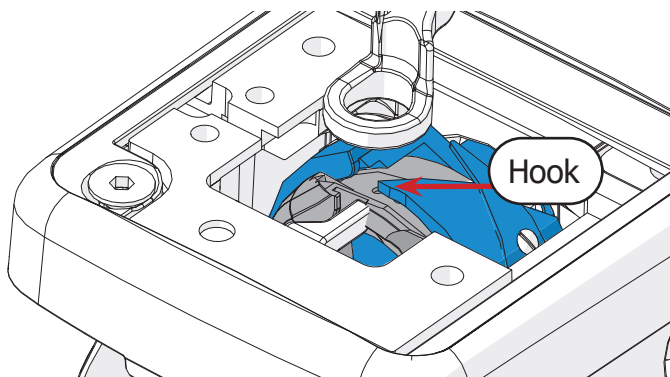

- 8 Hold the hook in place and carefully rotate the hand wheel counter-clockwise to drop the **needle** (shown in gray) to its lowest point. Continue rotating the hand wheel the same direction. The needle should begin to raise up.

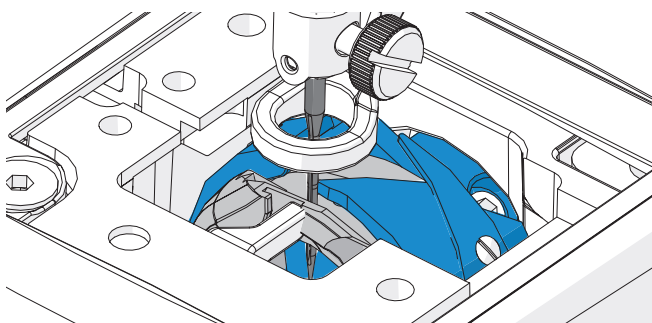

- 9 Stop raising the needle once the eye is about level with the **hook** (shown in blue). Do not continue to raise the needle. If the needle goes too high, start over at step 8.

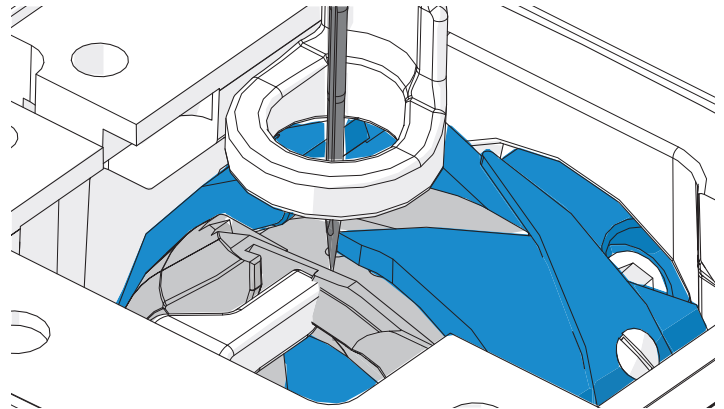

- 10 Slip the **timing spacer tool** (shown in blue) into the hook assembly with the flat side facing up. Then turn the timing tool until the flat side faces down.

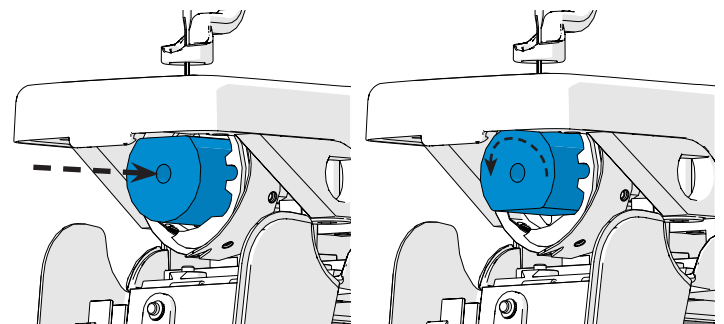

- 11 Turn the hand wheel the clockwise to bring the **needle** back down until it rests on top of the timing spacer. Do not let the needle rise to the top before bringing it back down or you will need to repeat steps 8-11.

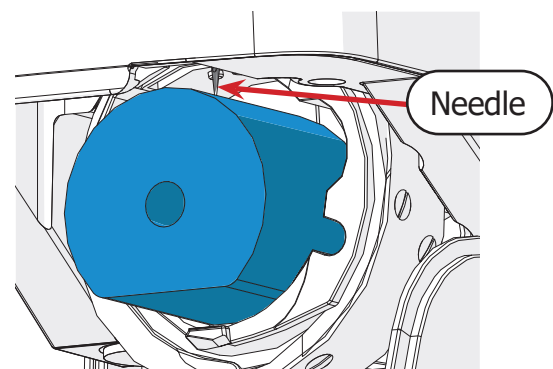

Timing the Machine (continued)

- 12 Position the tip of the **hook** (shown in blue) with the center of the **Needle Scarf** (shown in gray). This is easier to see from the back of the machine.

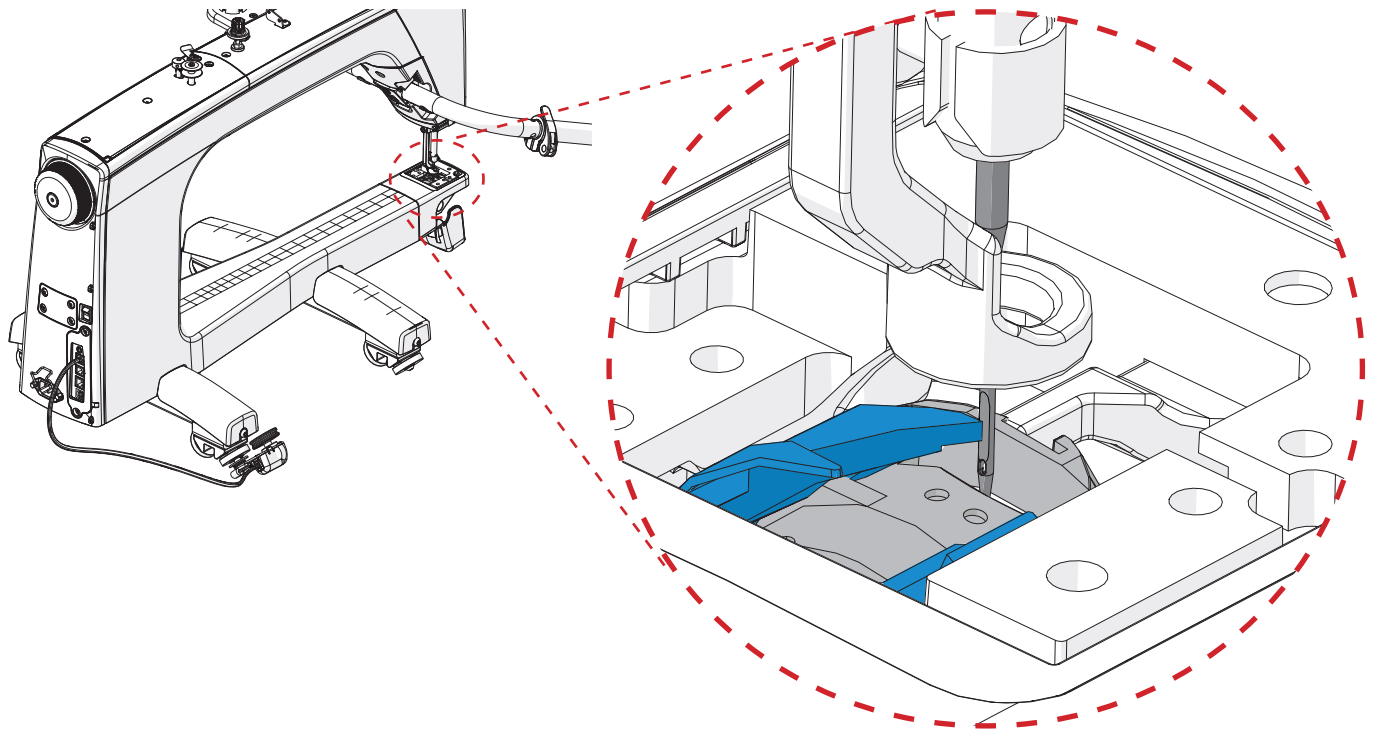

- 13 Pull the hook assembly toward the front of the machine until the hook is as close to the needle as possible without touching.

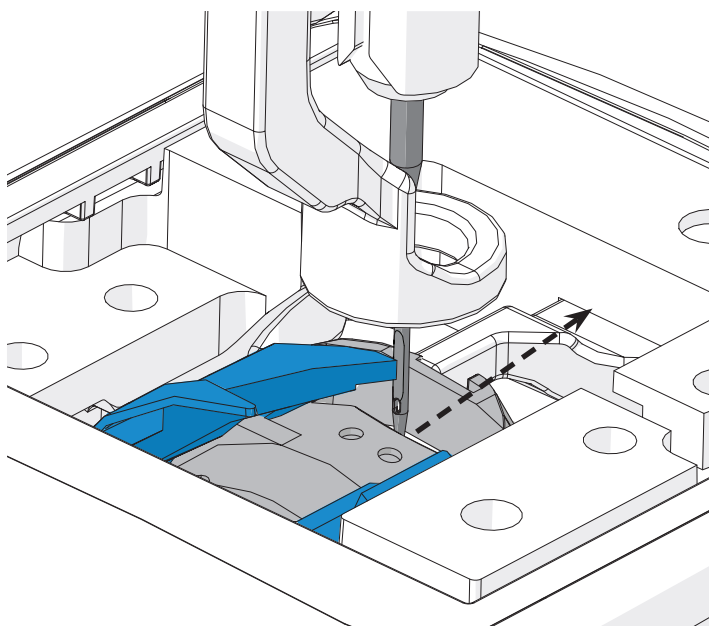

- 14 Use the 2 mm Allen wrench to tighten one of the three **set screws** through the timing cut-out window on the left.

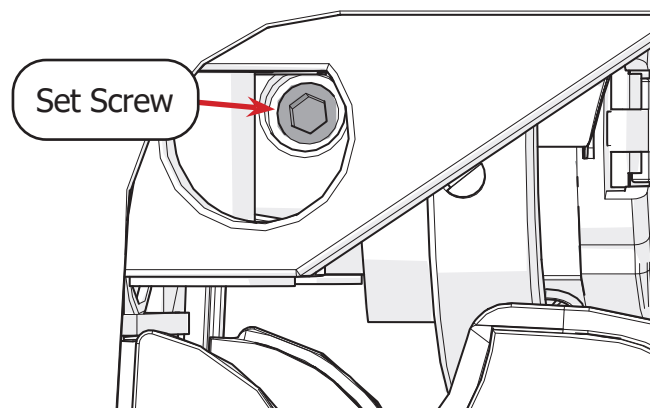

- 15 Turn the timing spacer tool until the flat side is facing up and then remove it from the machine.

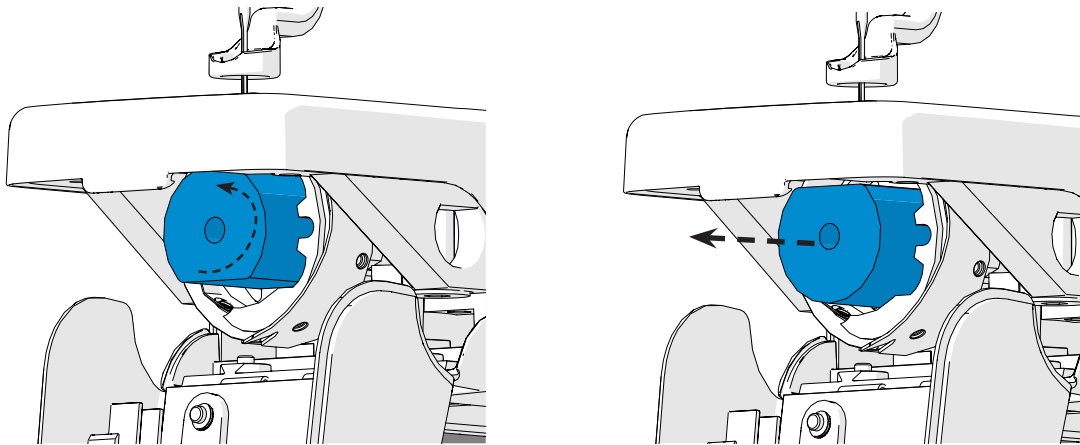

- 16 Turn the hand wheel a full rotation to listen for clicking noises and to ensure the needle does not bend or hit the hook

- 17 Tighten the two remaining **set screws** through the timing cut-out.

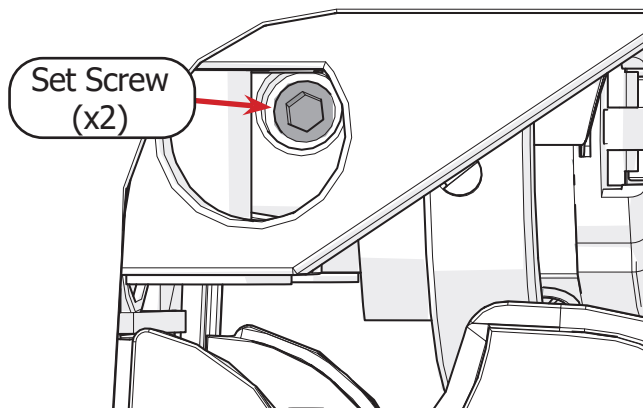

- 18 Replace and align the needle plate (see page 83).

- 19 Replace the bobbin case (see page 34).

- 20 Test the machine and listen for any unusual noises. If there are any skipped stitches, the hook is too far away from the needle. If the thread breaks, the hook is too close to the needle.



Appendix

This section of this manual covers additional information on quilting with your machine.

Choosing Your Needle	page 101
Choosing Your Thread	page 103
Choosing Your Fabric and Batting	page 106
Troubleshooting Guide	page 107
Index	page 109

Choosing Your Needle

Using the wrong type of needle, or using a needle that is bent, broken, or blunt, can damage the fabric, the machine, and needle. For best results:

- Use the recommended needle style for your machine (see below).
- Use the needle size appropriate for the weight and type of thread you're using (see below).
- Never use a needle that is dull, bent, burred, or damaged.
- Use multi-directional needles.
- Change your needle after 8 hours of use and at the beginning of each project.

Needle Style

The following are the recommended needle styles for your machine:

- DPx5 MR
- 134 MR
- 1955 MR

Needle Sizes

Choose the size of your needle based upon the thread you're using. Thicker thread requires a thicker needle. Remember, the thicker the thread, the lower the thread weight (wt.) number.

Needle Size	Thread Size and Type
14 / 90	<ul style="list-style-type: none"> • mono-filament • 100 wt. silk • 60 wt. polyester
16 / 100	<ul style="list-style-type: none"> • mono-filament • 60 wt. polyester or cotton • 50 wt. cotton
18 / 110	<ul style="list-style-type: none"> • 50 wt. polyester • 40 wt. cottons and polyester • 30 wt. cotton and polyester
20 / 125	<ul style="list-style-type: none"> • 30 wt. or heavier of any thread

Needle Diagram

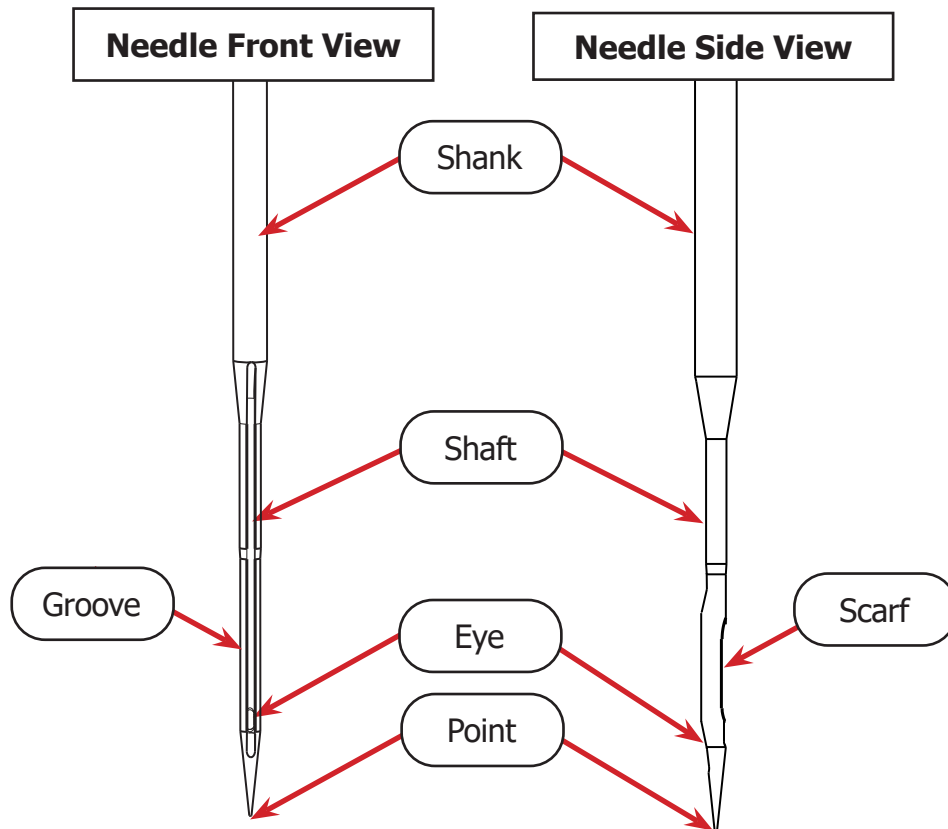

- **Shank:** Where the needle bar grasps the needle.
- **Shaft:** The long, narrow part of the needle. Needle size is based upon the diameter of the needle shaft.
- **Groove:** Reaching from the top to the bottom of the needle shaft, the groove allows thread to pass through the fabric more easily and without getting damaged.
- **Eye:** Hole near needle point where the needle is threaded.
- **Scarf:** A cut-away on the back of the needle that allows the needle to fit smoothly within the hook assembly when quilting.
- **Point:** The sharp end of the needle. Choose the type of needle point to fit your project, and always replace your needle once the point is dull.

Choosing Your Thread

Choosing the best thread for your project is just as important as choosing the correct needle. Good thread is strong and can pass the “Yank Test” (see page 37). It holds its color well over time (colorfast), and uses long fibers (extra-long staple) that resist creating lint.

Thread type and size determines not only which needle size to choose and what the thread tension must be set to on your machine, but also how visible the thread is on the project.

For best results:

- Use a cone-style thread unless you have the thread spool accessory for your machine.
- Test the strength of thread before use with the “Yank Test” (see page 37).
- Practice using new thread on spare quilting materials to find the ideal thread tension. Write this information down and store it with your thread for later reference.
- Keep thread out of sunlight to prevent fading, and do not store near extreme temperatures.
- Select thread that is ideal for the fabric you’re using (see the chart below).
- Use similar thread for top and bottom thread.

Thread Type Guide

Threads can be multiple strands, called ply, spun together, or they can be single ply. The fibers that make up the ply can come from many sources, but the most common threads used in quilting are made from cotton, polyester, and silk. The unique properties of each material make some threads better suited for use on some fabrics than others.

Thread Type	Ideal Fabric
Cotton	<ul style="list-style-type: none"> • Cotton • Linen • Rayon
Polyester	<ul style="list-style-type: none"> • Knit or Stretch • Woven synthetic
Silk	<ul style="list-style-type: none"> • Silk • Wool • Basting thread for all fabrics

Thread Size

The thickness of the thread is called the weight (wt.). This number is usually stamped on the edge of the top or bottom of the thread cone. Notice that as the thread becomes heavier and thicker, the weight decreases:

- 60 weight: Very thin, fine thread that will blend in to the fabric.
- 40 weight: Thicker thread that will show up on the fabric.

Note: Choose matching weight and thread type when picking top and bottom (bobbin) threads.

Tip: Not all manufacturers will have the same sizing method for their thread. Threads can be measured by weight, tex, denier, or scaling that is unique to its brand. Take the time to understand how the sizing works for a brand you're considering, and keep a few common sewing rules in mind:

- The thicker the thread, the larger the needle required. A needle that is too thin can shred thread.
- The thinner the thread, the smaller the needle should be. A needle that is too large will cause uneven stitching and can leave holes in the fabric.

Thread Processing

Sometimes thread is processed to change its properties. The chart below lists the processes common to cotton and polyester. No extra processing or treatments are typical for silk.

Thread Type	Processing
Cotton	<ul style="list-style-type: none"> • Mercerized: Treated to improve strength and colorfastness. • Glazed: Waxed or coated to give a polished appearance. The coating may rub off and build up in machine. • Gassed: Exposed briefly to a gas flame to burn away fuzz and lint, giving a smooth appearance.
Polyester	<ul style="list-style-type: none"> • Lubricated: Treated with lubricant to reduce friction. Avoid thread that is oily to the touch. • Bonded: Treated with resin to increase strength. This is typically used for heavy-duty applications, such as upholstery.

Our Recommended Thread

Finesse thread is specially-designed for quilting by the Grace Company. It can be used with domestic (sewing) and quilting machines, and comes in 60 colors.

- 100% Polyester, 3-ply thread
- 1,500 yards mini-cone
- 50 wt.
- 110/18 or 100/16 quilting machine needle
- Topstitch 90/14 sewing machine needle



Choosing Your Fabric and Batting

Fabric

Some fabrics are not recommended for use with your quilting machine. Thick fabrics, such as denim or leather, have a lot of resistance that can bend or snap a needle, and misalign or break internal machinery. When quilting, avoid any fabrics that are difficult to pierce, and take care that the fabric layers of the quilt are well balanced.

Batting

To choose the best batting for your project, consider the look and feel of the quilt that you're making. Batting thickness is measured by its loft. A low loft batting is thinner and lighter, ideal for a quilt with a flatter appearance. High loft batting should be used if a fluffy, full quilt is desired.

Typically, wool batting is the thickest batting while bamboo is the lightest. Wool provides the most warmth, followed by polyester, and then cotton.

Troubleshooting Guide

Issue	Cause(s)	Solution
Machine won't turn on.	Loose cables	Check that cables are securely plugged in (page 28).
	Machine is not turned on	Check power button is pressed down correctly (page 28).
	If problem persists, please contact a Grace Company support technician. Call (800) 264-0644 .	
Stitches are skipped.	Damaged needle	Check needle (page 76).
	Machine improperly threaded	Check that all tensioners and guides were threaded correctly (page 37).
	Bobbin wound or threaded incorrectly	Check that the bobbin was inserted the correct direction in the case (page 34).
	Incorrect thread tension	Adjust top thread tension (page 60). Adjust bottom thread tension (page 34).
	Hopping foot incorrect distance from needle plate	Check distance with height gauge. Reinstall hopping foot if incorrect (page 78).
	If problem persists, please contact a Grace Company support technician. Call (800) 264-0644 .	
Thread is breaking.	Damaged needle	Check needle (page 76).
	Incorrect thread tension	Adjust top thread tension (page 60). Adjust bottom thread tension (page 34).
	Machine improperly threaded	Check guides and tensioners for accidental double-wrapping (page 37).
	Stitching in place too long	Keep machine moving to avoid stitch build-up in one place, or switch to regulated precise quilting mode (page 47).

Issue	Cause(s)	Solution
Thread is breaking.	Bobbin inserted incorrectly	Check bobbin is the correct direction in the case and inserted firmly (clicked) into the machine (page 34).
	Debris on tension discs	Clean the machine (page 73).
	Burred bobbin case	Check bobbin case for sharp edges. Contact your dealer to replace if needed.
	Needle plate is rubbing needle	Check that needle plate is centered and does not hit needle (page 83).
	If problem persists, please contact a Grace Company support technician. Call (800) 264-0644 .	
Machine is running loud.	Machine and/or hook assembly needs oiling	Oil the machine and hook assembly (page 73).
	Bobbin winder is on	Press the "stop" button on the bobbin winder.
	If problem persists, please contact a Grace Company support technician. Call (800) 264-0644 .	
Thread is bunching up in hook assembly (bobbin case area).	Bobbin wound or threaded incorrectly	Check that the bobbin was threaded correctly and inserted the correct direction in the case (page 34).
	Machine improperly threaded	Check that all tensioners and guides were threaded (page 37).
	Incorrect thread tension	Adjust top thread tension (page 60). Adjust bottom thread tension (page 34).
	Bobbin case has damaged or missing spring	Check inside bobbin case to see spring. Contact your dealer to replace if needed.
	If problem persists, please contact a Grace Company support technician. Call (800) 264-0644 .	

Index

Symbols

2.5 mm T-handle Allen wrench	2, 23, 25, 26
2 mm T-handle Allen wrench	96
3 mm T-handle Allen wrench	23, 31, 78, 93
4 mm Allen wrench	12
4 mm Allen wrench (L-shaped)	12
4 mm T-handle Allen wrench	2, 18, 20, 26, 90
7 inch touch display	23

A

adjust handles	20
adjust hopping foot	78
animated instructions	xvi

B

back left wheel base cover	18
back right wheel base cover	18
back wheel base assembly	12
basting	53
batting	106
bobbin	31, 88
bobbin case	34
bobbin case tension	35
bobbin estimator	55
bobbin fill adjustment	33
bobbin wind troubleshooting	88
bottle	72
bottom thread tension	35
brightness (needle area)	45
brightness (screen)	45

C

calculator	65
cleaning	73
click sound	45
controls	46
cruise sewing mode	49

D

defaults	44
display	23
display cable port	xi

E

edge warning	57
edge warning light	45
edge warning sound	45
electrical	vii
encoder	2, 26, 90
encoder (lower)	2
encoder port	x, 27
encoder spring	90
encoder (upper)	26

F

fabric	106
factory reset	45
features	vii
Finesse thread	105
firmware	87
flat-head screwdriver	93, 96
front left wheel base cover	18
front right wheel base cover	18
front wheel base assembly	12

G

getting started	67
grounding instructions	ii
guide loops	32, 39

H

handle adjustment	20
handlebar assembly	20
handlebar controls	46
hand wheel	viii, ix
help guides	30
hook assembly	ix, 93, 96
hook holder	93
hopping foot	78
hopping foot height tool	78

I

included parts and tools	xii
--------------------------------	-----

L

lamp	ix, 45
large thread tensioner	60
layout	viii
lint brush	73

M

M4 x 8 mm SBHCS	25
M6 shoulder bolt	12
M6 x 16 mm SBHCS	19
M6 x 20 mm SBHCS	12
machine dimensions	vii
machine layout	viii
machine maintenance	71
machine settings	44
machine specifications	vii
machine timing	96
manual sewing mode	51
measurements	63
metric	45

N

needle button.....	45
needle change.....	76
needle diagram	102
needle groove	102
needle magnet.....	76
needle plate.....	83
needle scarf	102
needle size.....	101
needle stop position.....	45

O

oil bottle	72
oiling 72, 73	
overspeed light.....	45
overspeed sound	45

P

parts xii	
parts of machine	viii
power cable	28
power cable retainer	28
power port.....	x, 28
power switch.....	x, 28
precise sewing mode	47
preferences.....	44
processed threads	104
pull up bobbin thread.....	67

Q

Quilter's Creative Touch tablet port	x
--	---

R

run time.....	66
---------------	----

S

safety instructions	i
screen installation.....	23
screwdriver	93, 96
settings menu	44
sewing mode: basting.....	53
sewing mode: cruise.....	49
sewing mode: manual.....	51
sewing mode: precise	47
specifications.....	vii
stitch count.....	66
stitches per centimeter.....	45
stitches per inch	45
support.....	107
system info	45

T

thread	31, 37, 103
thread cutter	32, 41
threading machine.....	37
threading the machine.....	37
thread size.....	104
thread strength	37
thread tension.....	35, 60
timing machine.....	96
timing spacer	96
tools xii	
track run time	66
track stitch count.....	66
troubleshooting guide	107

U

units 45	
USB connector port.....	x

V

video instructions	xvi
--------------------------	-----

W

wheel alignment.....	14
wheel base.....	12
wheel covers.....	18
wheel installation.....	12
wheels.....	12
winding a bobbin.....	31

Y

yank test.....	37
----------------	----

Information on the disposal for Waste Electrical & Electronic Equipment (WEEE): This symbol on the products and accompanying documents means that used electrical and electronic products should not be mixed with general household waste. For proper disposal for treatment, recovery and recycling, please take these products to designated collection points where they will be accepted on a free-of-charge basis. In some countries you may be able to return your products to your local retailer upon the purchase of a new product. Disposing of this product correctly will help you save valuable resources and prevent any possible effects on human health and the environment, which could otherwise arise from inappropriate waste handling. Please contact your local authority for further details of your nearest collection point for WEEE.





www.graceframe.com

1-801-485-6688