



US008826789B2

(12) **United States Patent**
Bagley

(10) **Patent No.:** **US 8,826,789 B2**
(45) **Date of Patent:** **Sep. 9, 2014**

(54) **FABRIC RULER WITH RAISED EDGE GUIDE AND ROTARY CUTTING TOOL WITH GROOVE FOR ENGAGING THE EDGE GUIDES**

(76) Inventor: **Jim Bagley**, Bluffdale, UT (US)

(*) Notice: Subject to any disclaimer, the term of this patent is extended or adjusted under 35 U.S.C. 154(b) by 557 days.

(21) Appl. No.: **12/572,936**

(22) Filed: **Oct. 2, 2009**

(65) **Prior Publication Data**

US 2011/0078908 A1 Apr. 7, 2011

(51) **Int. Cl.**

B26B 27/00 (2006.01)
B26B 29/06 (2006.01)
B43L 12/00 (2006.01)
B43L 7/00 (2006.01)
B26B 25/00 (2006.01)

(52) **U.S. Cl.**

CPC **B26B 29/06** (2013.01); **B43L 12/00** (2013.01); **B43L 7/005** (2013.01); **B26B 25/005** (2013.01)
USPC **83/574**; 30/292; 30/294; 30/319

(58) **Field of Classification Search**

CPC B26B 25/00; B26B 29/06; B26B 29/05; B26B 1/08; B26B 1/02; B43L 7/00
USPC 30/286, 289, 291, 292, 31, 293, 282, 30/294, 307; 83/455

See application file for complete search history.

(56) **References Cited**

U.S. PATENT DOCUMENTS

463,838 A * 11/1891 Johnson 30/292
623,000 A * 4/1899 Erkenbreck 30/292

| | | | | |
|-----------------|---------|----------------|-------|--------|
| 636,468 A * | 11/1899 | Strange | | 30/292 |
| 745,517 A * | 12/1903 | Perks | | 30/292 |
| 1,534,576 A * | 4/1925 | Edgren | | 30/292 |
| 2,695,447 A * | 11/1954 | Maynard | | 30/2 |
| 4,779,346 A | 10/1988 | Schafer | | |
| 5,299,355 A * | 4/1994 | Boda et al. | | 30/162 |
| 5,493,781 A * | 2/1996 | Saito | | 30/162 |
| 5,711,077 A * | 1/1998 | Schulz et al. | | 30/160 |
| 5,819,422 A | 10/1998 | Schafer | | |
| 6,643,936 B2 * | 11/2003 | Carlson et al. | | 30/162 |
| 6,839,971 B2 | 1/2005 | Schafer et al. | | |
| 6,854,189 B2 | 2/2005 | Schafer | | |
| 7,073,263 B2 * | 7/2006 | Kawasaki | | 30/292 |
| 7,178,249 B2 | 2/2007 | Schafer | | |
| 7,251,898 B2 | 8/2007 | Schafer | | |
| 7,290,340 B2 * | 11/2007 | Lin | | 30/292 |
| 7,509,745 B2 | 3/2009 | Schafer et al. | | |
| 2003/0110653 A1 | 6/2003 | Schafer | | |
| 2004/0088870 A1 | 5/2004 | Schafer et al. | | |

(Continued)

Primary Examiner — Kenneth E. Peterson
Assistant Examiner — Jennifer Swinney
(74) *Attorney, Agent, or Firm* — Morriss O'Bryant Compagni

(57) **ABSTRACT**

Apparatus, systems and methods in accordance with the present invention are related to rotary cutting tools and rulers. In one illustrative embodiment of a system in accordance with the present invention, a ruler for use with a rotary cutting tool has a guide ridge formed as a wall along a cutting edge of the ruler. A hand held rotary cutting tool has a groove in a cutting portion thereof that corresponds to the guide ridge and resides thereon during cutting. The rotary blade of the hand held rotary cutter is maintained in a position adjacent to the cutting edge of the ruler as the cutter is advanced long the ruler cutting edge by the interaction of the groove and the guide ridge. The cutter may include blade guard locking features and a blade depth control for additional safety and control during use.

28 Claims, 9 Drawing Sheets

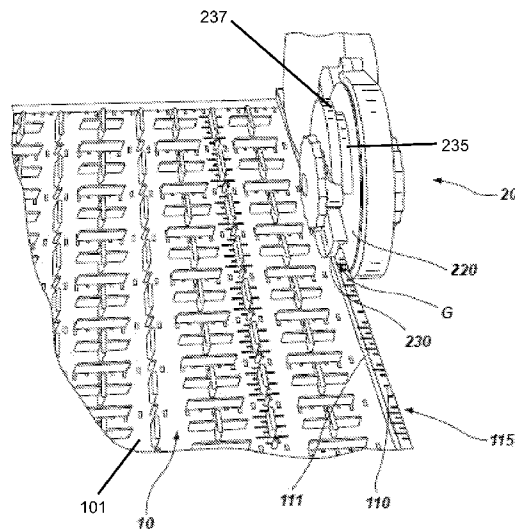

(56)

References Cited

U.S. PATENT DOCUMENTS

| | | | | | | |
|-------------------|--------|---------------------|--------|-----------------|--------|----------------|
| 2004/0187318 A1 * | 9/2004 | Mathieu et al. | 30/319 | 2005/0178013 A1 | 8/2005 | Schafer et al. |
| 2005/0132586 A1 | 6/2005 | Schafer | | 2006/0130344 A1 | 6/2006 | Schafer |
| | | | | 2007/0175052 A1 | 8/2007 | Schafer et al. |

* cited by examiner

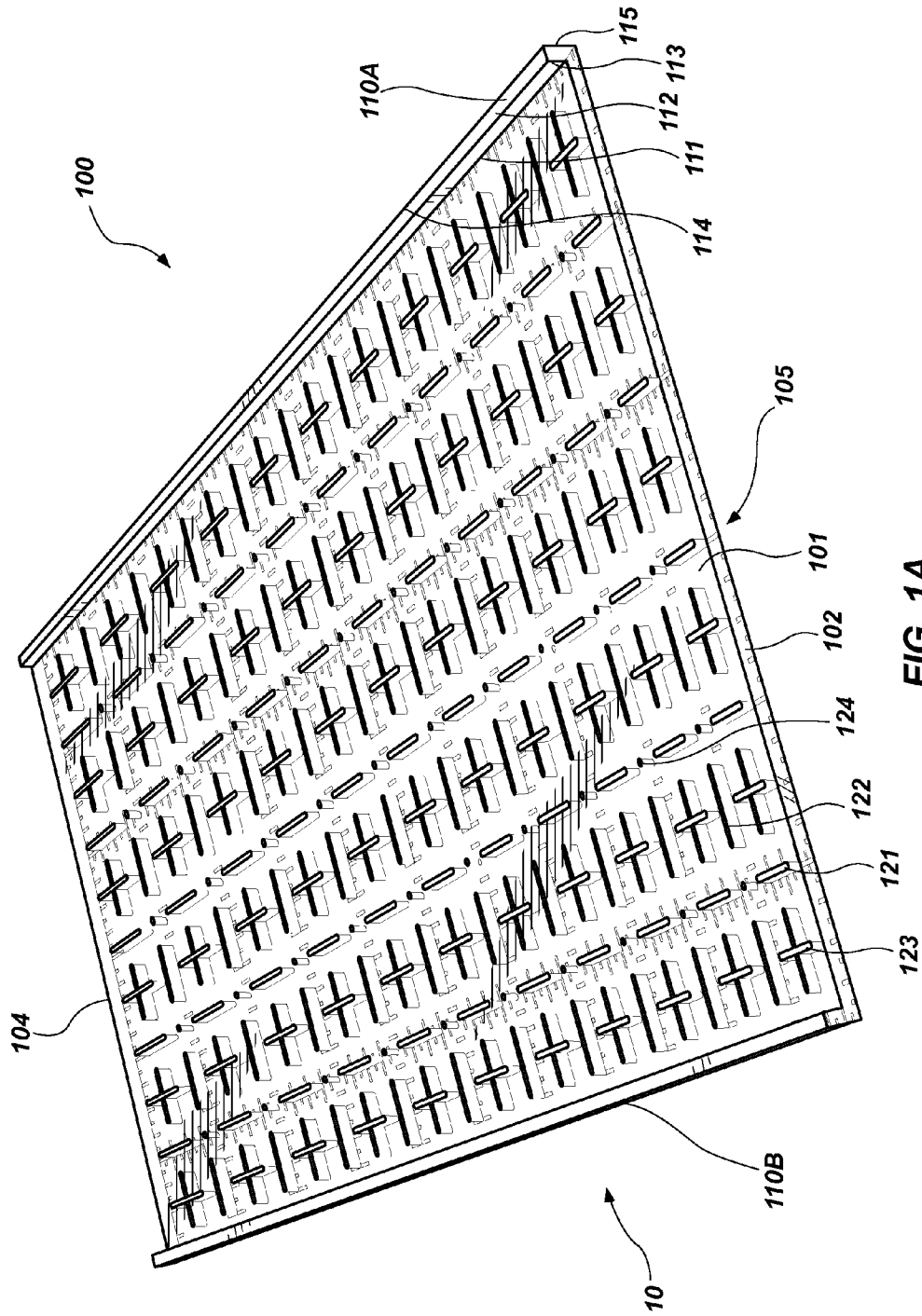

FIG. 1A

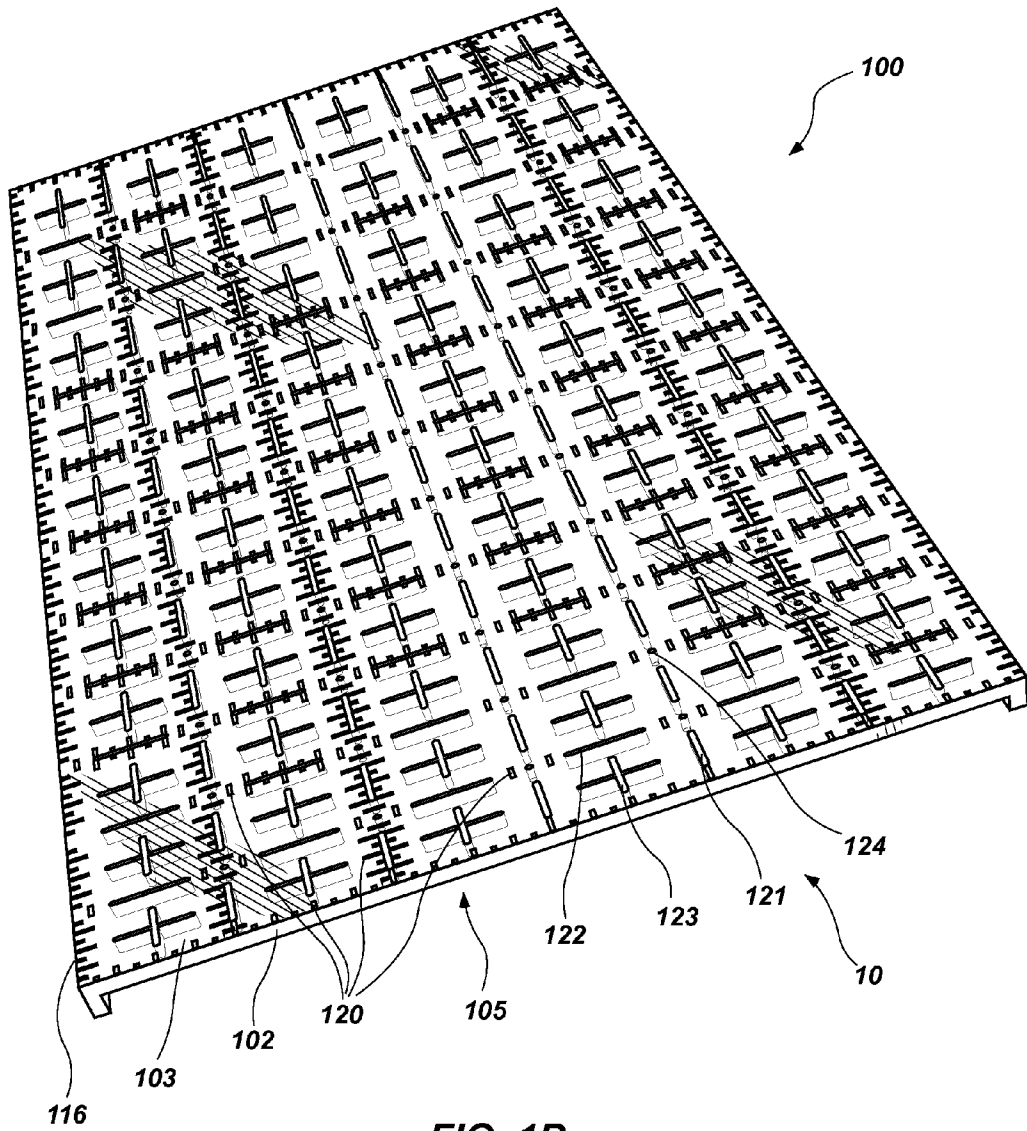

FIG. 1B

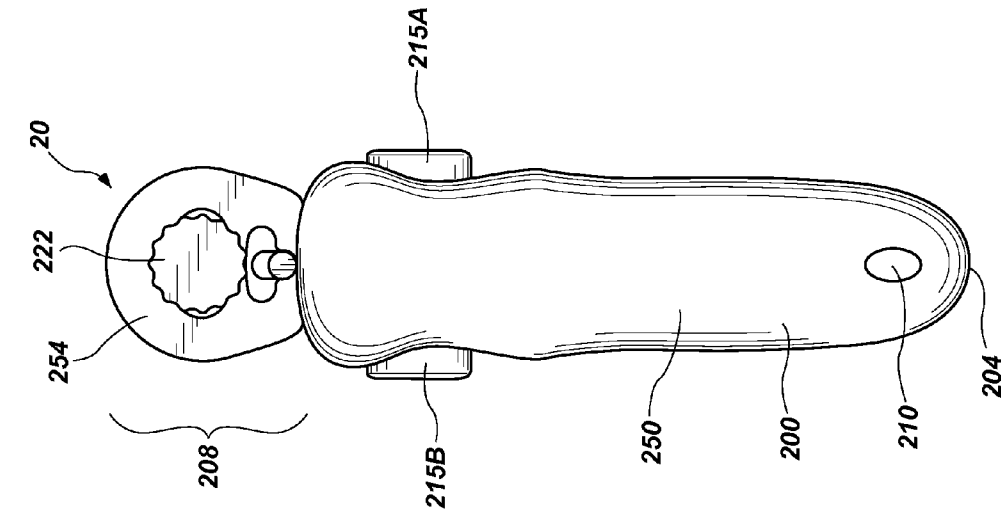

FIG. 2A

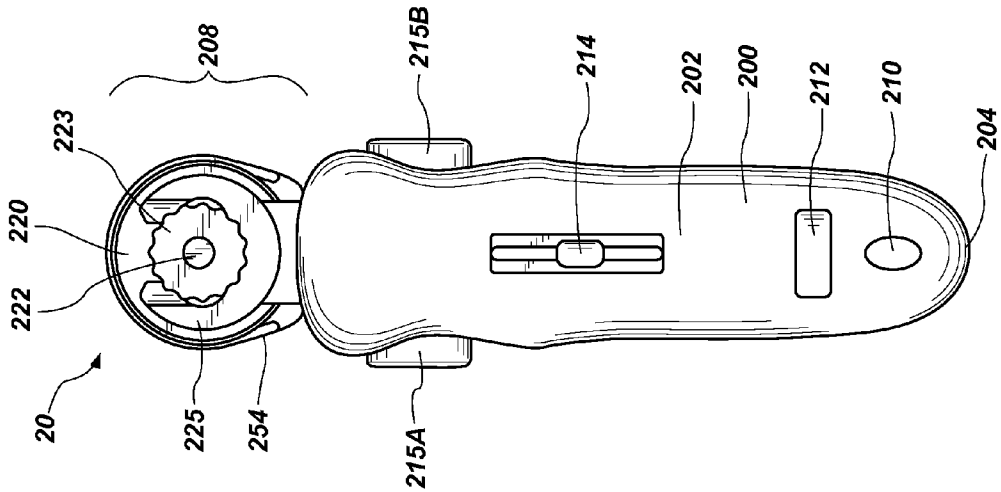

FIG. 2B

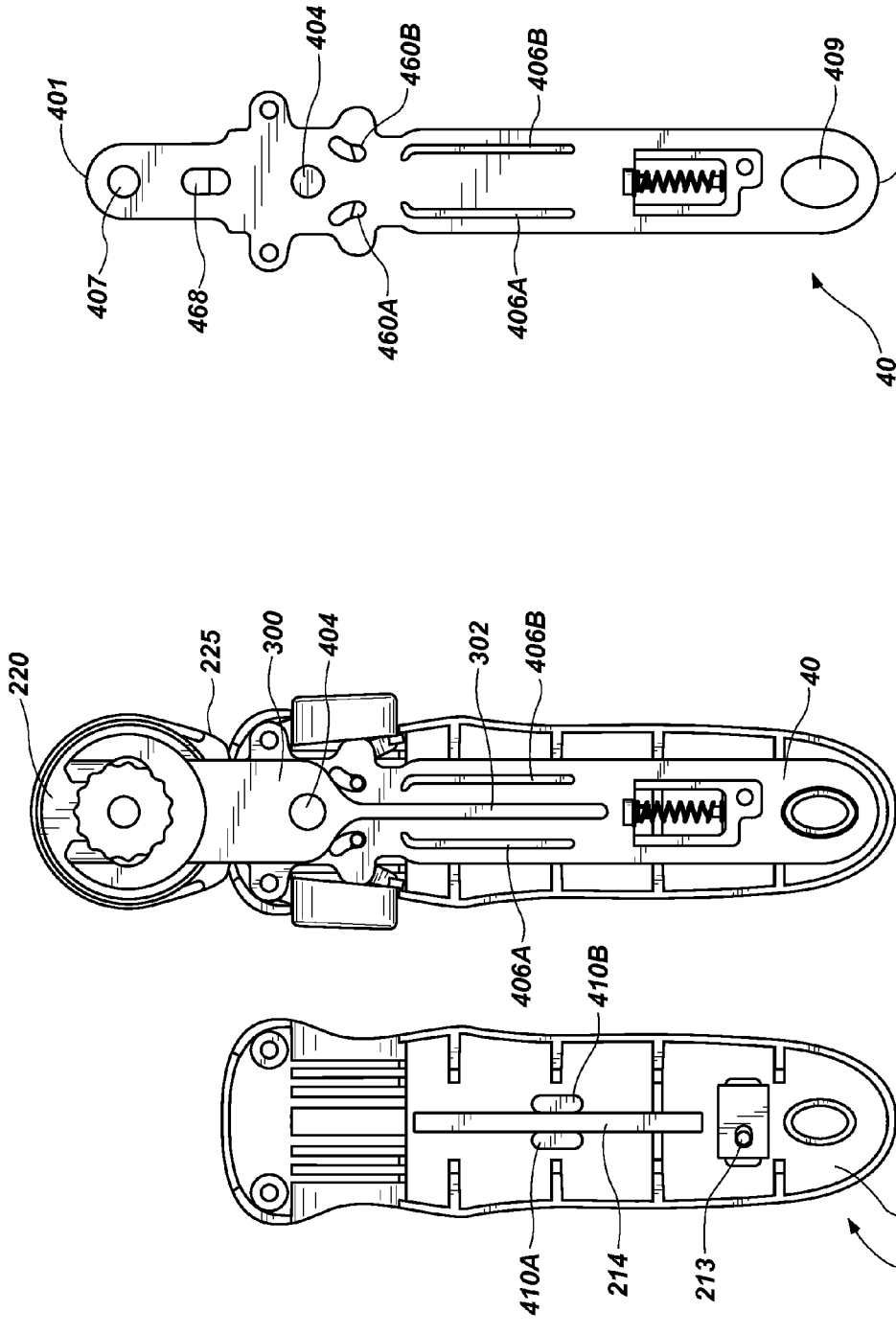

FIG. 4

FIG. 3

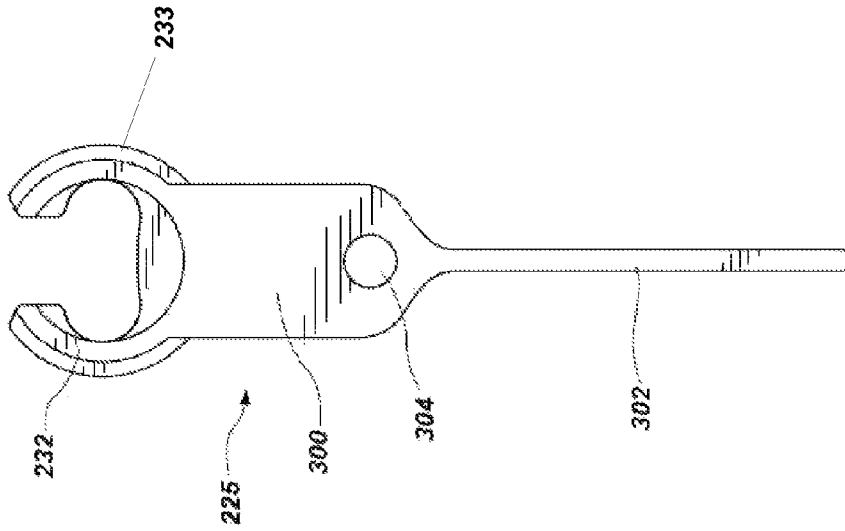

FIG. 5A

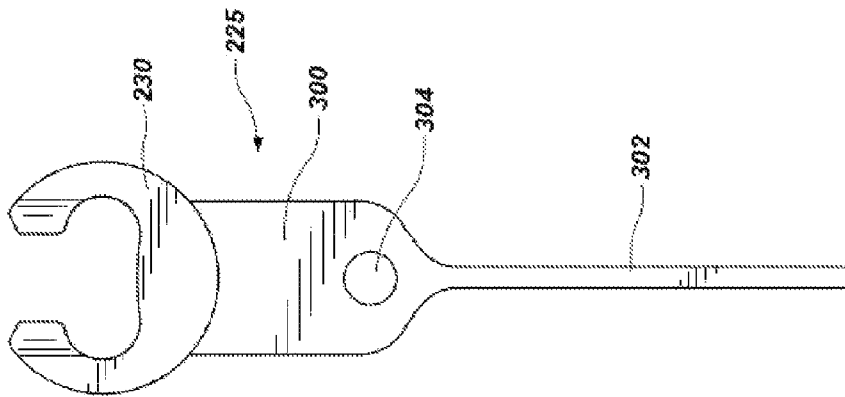

FIG. 5B

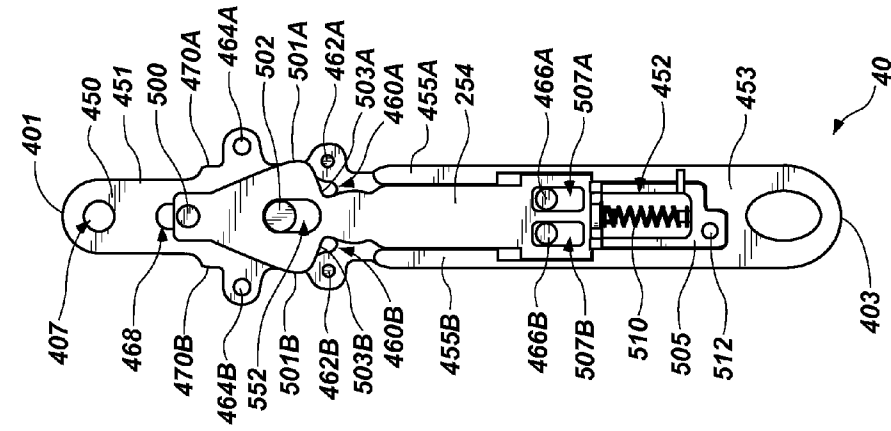

FIG. 7

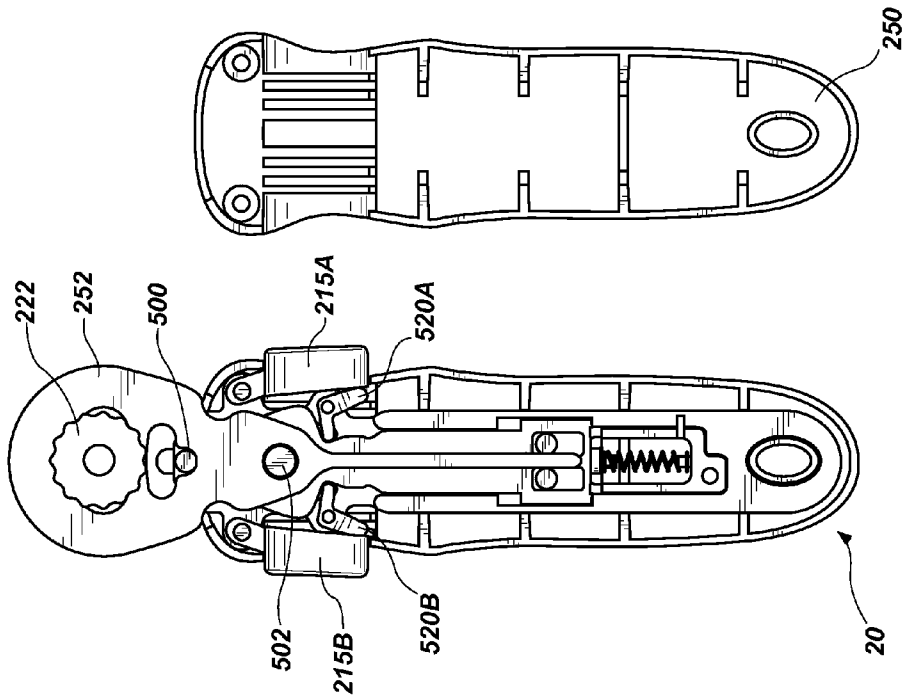

FIG. 6

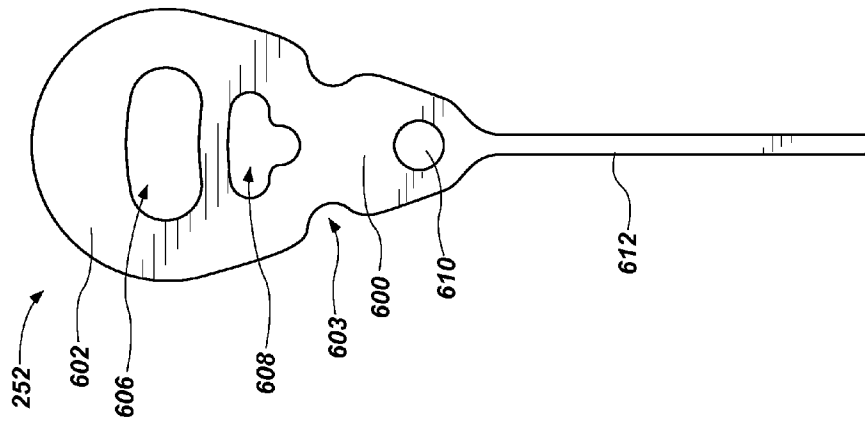

FIG. 8B

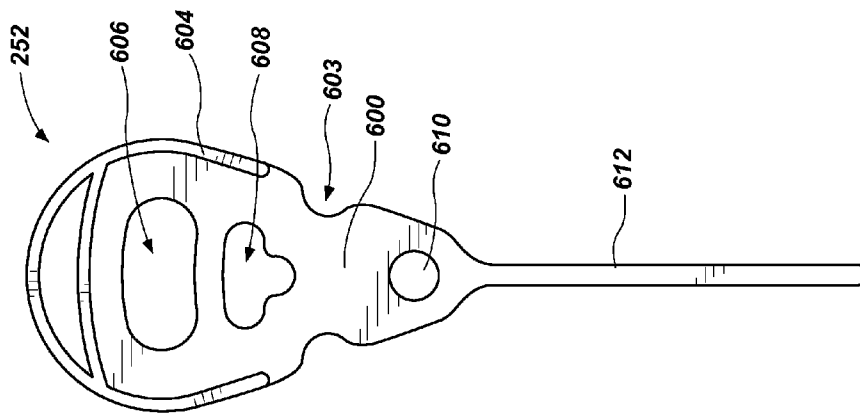

FIG. 8A

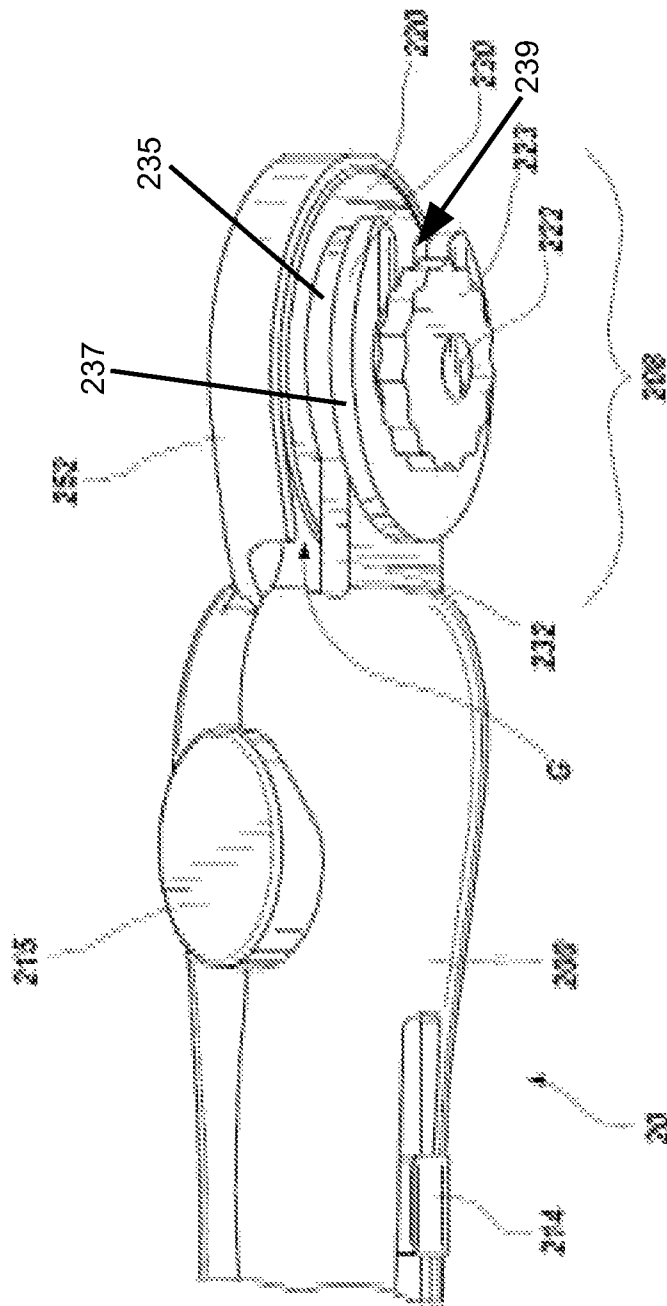

FIG. 9

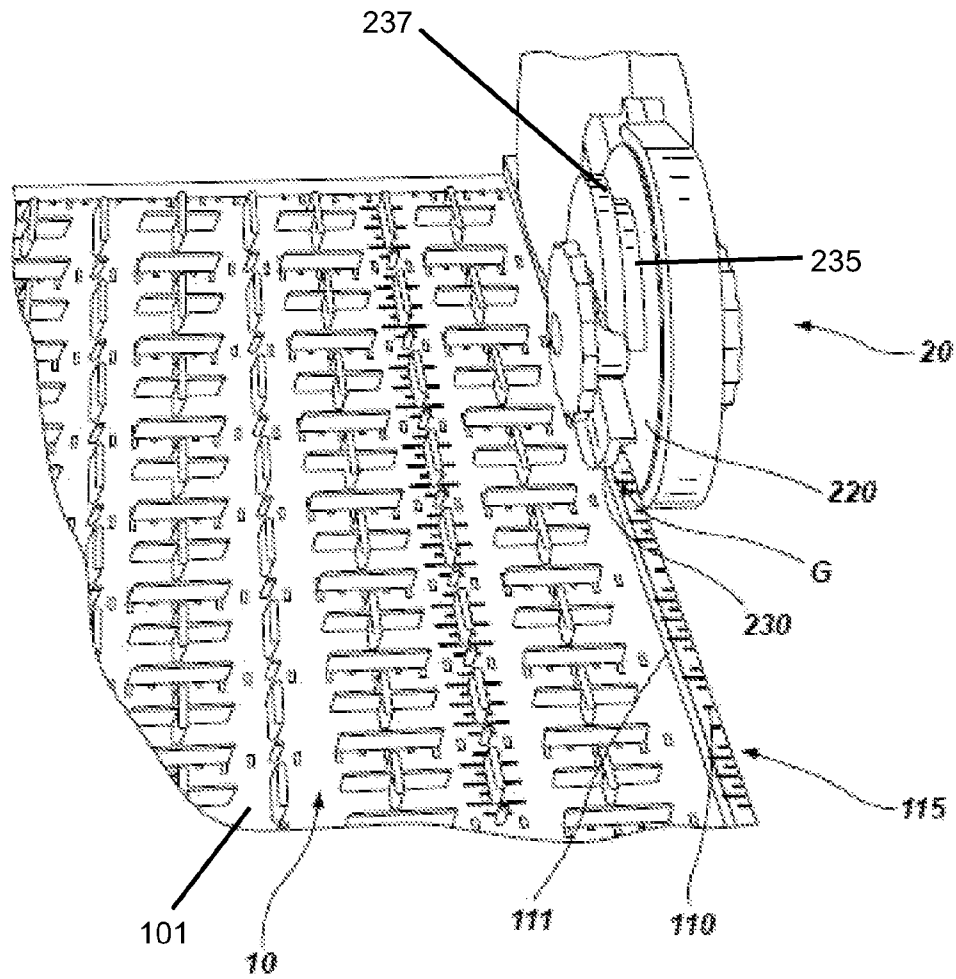

FIG. 10

1

**FABRIC RULER WITH RAISED EDGE GUIDE
AND ROTARY CUTTING TOOL WITH
GROOVE FOR ENGAGING THE EDGE
GUIDES**

TECHNICAL FIELD

The present invention relates to tools for cutting textiles and other materials, and in particular to rotary cutting tools and related items.

BACKGROUND

Rotary cutters are used for cutting fabric in quilt making and hobby sewing, among other uses. Such rotary cutters come in many different designs, each of which includes a handle portion and a "wheel blade" or rotary cutting blade, which is essentially a circular razor blade mounted on axle. The various designs for rotary cutters include differing handle shapes, for ease of use or user preference, with a rotary cutting blade rotatably mounted near one end. Various designs include differing blade guard features which are intended to reduce the potential for injury to a user.

Rotary cutters are typically used with a ruler that is laid on the fabric with the edge of the ruler used to guide the path of the blade during cutting by holding the edge of the blade against the side of the ruler. However, if either the ruler slips on the surface of the fabric during cutting or the cutter wanders from the ruler edge, a user can be injured by the rotary blade. Accordingly, some known rulers have guards that separate the cutting edge of the ruler from the typical placement of a users hand. There are also known rulers that have structures, such as barbs, for attaching to the fabric in order to reduce slipping. While these types of rulers have been able to reduce injuries ruler slippage, the issue of mis-cutting the fabric when the blade wandering away from the ruler remains unresolved.

Accordingly there exists a need for assemblies and devices that address these problems. A system or assembly that allowed for a rotary cutter to be used with a ruler and reduced the tendency for the rotary cutter to wander onto or away from the edge of a ruler during guided cutting would be an improvement in the art.

SUMMARY

Apparatus, systems and methods in accordance with the present invention are related to rotary cutting tools and rulers. In one illustrative embodiment of a system in accordance with the present invention, a ruler for use with a rotary cutting tool has a guide ridge formed as a wall along a cutting edge of the ruler. A hand held rotary cutting tool has a groove in a cutting portion thereof that corresponds to the guide ridge and resides thereon during cutting. The rotary blade of the hand held rotary cutter is maintained in a position adjacent to the cutting edge of the ruler as the cutter is advanced long the ruler cutting edge by the interaction of the groove and the guide ridge. The cutter may include blade guard locking features and a blade depth control for additional safety and control during use.

DESCRIPTION OF THE DRAWINGS

It will be appreciated by those of ordinary skill in the art that the elements depicted in the various, drawings are not necessarily to scale, but are for illustrative purposes only. The nature of the present invention, as well as other embodiments

2

of the present invention may be more clearly understood by reference to the following detailed description of the invention, to the appended claims, and to the several drawings attached hereto.

5 FIGS. 1A and 1B are perspective top and bottom views of an illustrative embodiment of a ruler for cutting sheet materials in accordance with the principles of the present invention.

10 FIGS. 2A and 2B are front and back views of an illustrative embodiment of a hand held rotary cutting tool in accordance with the principles of the present invention.

FIG. 3 is a front view of the hand held rotary cutting tool of FIGS. 2A and 2B with the front face of the case removed to reveal internal components.

15 FIG. 4 is a front view of the frame of the hand held rotary cutting tool of FIGS. 2A and 2B.

FIGS. 5A and 5B are front and back views of the cutting guide of the hand held rotary cutting tool of FIGS. 2A and 2B.

20 FIG. 6 is a back view of the hand held rotary cutting tool of FIGS. 2A and 2B with the back face of the case removed to reveal internal components.

FIG. 7 is a back view of the frame of the hand held rotary cutting tool of FIGS. 2A and 2B.

25 FIGS. 8A and 8B are front and back views of the blade guard of the hand held rotary cutting tool of FIGS. 2A and 2B.

FIG. 9 is a side view of a top portion of the hand held rotary cutting tool of FIGS. 2A and 2B.

30 FIG. 10 is a front perspective view of the hand held rotary cutting tool of FIGS. 2A and 2B interacting with the ruler of FIGS. 1A and 1B as a cutting system in accordance with the principles of the present invention.

DESCRIPTION

35 For the purposes of promoting an understanding of the principles of the invention, reference will now be made to the embodiment illustrated in the drawings and specific language will be used to describe the same. It will nevertheless be understood that no limitation of the scope of the invention is thereby intended, such alterations and further modifications in the illustrated device, and such further applications of the principles of the invention as illustrated therein being contemplated as would normally occur to one skilled in the art to which the invention relates.

40 FIGS. 1A and 1B depict a ruler 10 for use in accordance with the systems and methods of the present invention. As depicted ruler 10 has a generally planar body 100 having a rectangular shape. A planar midsection 105 is defined by upper surface 101 and lower surface 103 which extend longitudinally from a first edge 102 to an opposite second edge 104. The longitudinal edges of the ruler 10 are defined by a first guide ridge 110A and an opposite second guide ridge 110B along the edge of body 100.

45 Each guide ridge 110 is formed as a vertical wall or ridge rising from the upper surface 101 along the entire longitudinal edge of the body 100. An inner sidewall 111 extends from the upper surface 101 of the planar body 100 to intersect ridge top surface 112 at an inner corner 113 that may be rounded. Ridge top surface 112 extends from inner corner 113 to outer corner 114 where it perpendicularly intersects vertical outer sidewall 115, which extends from outer corner 114 to meet a lower surface 103 at a lower corner 116. Each guide ridge functions as a guide for cutting with rotary cutter devices in accordance with the present invention, as discussed further herein.

65 In some embodiments in accordance with the present invention, ruler 10 may be formed from translucent or trans-

parent materials, allowing a user to view a textile or sheet material which the ruler **10** is placed over during use through body **100**.

Ruler **10** includes a number of features to facilitate use in marking and cutting textiles and other sheet materials. For example, length marking indicia may be included on the ruler **10**. In the depicted embodiment, such indicia are formed as a series of raised protuberances or bumps **120** disposed on the lower surface **103** of the body **100**. As depicted, the indicia may be placed both longitudinally and transversely to create a set of markings that form a grid pattern on the ruler **10**. As depicted, these markings reflect may reflect inches and parts thereof, or may be any desired units. By forming the markings as a series of bumps **120** on the lower surface **103**, the markings act to grip material lying underneath the ruler **10** during use, reducing the likelihood of slipping when cutting or marking.

In addition to bumps **120** the markings may be formed by applying a colored material to the ruler, such as a paint or dye, which may improve visualization of markings disposed on bottom surface **103** when viewed through the body **100** of the ruler. In such embodiments, the paint or dye may be selected to have non-slip properties, such as a relatively high coefficient for friction compared to the body of the ruler, in order to reduce the likelihood of slipping during use.

Planar midsection **105** may feature a number of openings through the body **100** in order to allow for marking materials through the ruler or for the ruler to be secured to underlying material. In the depicted embodiment, there are both longitudinal slots **121** and transverse slots **122** arrayed as a series of lines forming a grid pattern through the ruler **10**. Each slot passes through the body **100** from the upper surface **101** to the lower surface **103** and is of sufficient width to allow marking therethrough. Additionally, the depicted embodiment features a pattern of cross-shaped slots **123** formed by intersecting transverse and longitudinal slots that are disposed within the grid pattern of the longitudinal slots **121** and transverse slots **122**. Each cross shaped slot **123** similarly passes through the body **100** from the upper surface **101** to the lower surface **103** and is of sufficient width to allow marking therethrough.

In addition to the slots **121**, **122**, and **123**, smaller openings, such as the round pinholes **124** may pass through the body **100** from the upper surface **101** to the lower surface **103**. In the depicted embodiment, the pinholes **124** are placed in alignment with the slots **121** and **122**, thus forming a part of the grid pattern. In use, a user could place a pin through one or more holes **124** to secure the ruler **10** to an underlying textile or other material in order to further reduce the likelihood of slippage. It will be appreciated that the depicted pattern of slots and holes is only exemplary and any desired pattern useful for marking and cutting sheet materials may be used.

FIGS. **2A** and **2B** depict a hand held rotary cutting tool **20** in accordance with the principles of the present invention. As depicted the tool **20** includes an outer case **200** which forms a handle for a user of the tool **20**. The case **200** may be formed as a two piece unit having a front face **202** which attaches to an opposite back face. Front face **202** and back face **250** are each formed as curved units that attach to one another around their peripheries to form a handle having a tapered bottom end **204** and a wider top end **206**. A lanyard hole **210** may be formed through the case **200** near the bottom end **204**, as a hole formed by the meeting of sidewall holes formed in each of front face **202** and back face **250**, as depicted.

At top end **206**, an opening is formed by opposite recesses in the edges of the two faces, from which some components of the cutting portion **208** extend out from the interior of the handle. The visible portions of the cutting portion include

rotary blade **220**, the axle bolt **222**, and retaining nut **223**, as well as portions of cutting guide **225**, blade guard **252** and guard lock component **254**.

A number of functional components are contained within the case **200** and may be actuated by controls accessible at the case **200** to utilize the features of the cutting tool. These various components are discussed further herein.

A locking selector **212** may be disposed on front face **202**, which is actuated to select whether guard lock component **254** may be actuated to allow the blade guard **252** to retract from the cutting surface of the rotary blade **220**. As depicted, the locking selector **212** may be accessible as a lever type button on the front face **202**.

Moving up the handle, a blade guide control or cutting depth selector **214** may also be disposed on the handle. As depicted, this may be a sliding button or knob accessible on the front face **202**. Adjustment of the blade guide control determines the deflection of the cutting guide **225** during operation, and thus depth of the cut made by the rotary blade **220**.

Near top end **206** two guard release buttons **215A** and **2154B** are disposed, one each on the opposite sides of the cutter **20** handle. When the locking selector **212** is actuated to allow the blade guard to retract, either guard release button may be depressed by a user to allow the blade guard **252** to retract from the cutting surface of the rotary blade **220**. Placement of the guard release buttons **215** at these locations allow a user to operate the cutter **20** in multiple positions and with either hand.

FIG. **3** depicts the cutter **20** with front face **202** removed to allow additional details of the cutting guide **225** and other components to be viewed. A central cutter frame **40** (depicted in isolation in FIGS. **4** and **7**) is formed as an elongate body **40** to which the other cutter **20** components are connected. Cutter frame **40** has a front side **402** with a generally planar configuration from a rounded top end **401** to a rounded bottom end **403**. Near top end **401**, an axle socket **407** is formed as a circular hole through the body **400**. For installation of rotary blade **220**, axle bolt **222** may be inserted through the axle socket **407** from the rear side to extending past front face **402**. The rotary blade **220** is may be placed thereover and secured with and retaining nut **223**.

A second opening may be formed near bottom end **403** which corresponds to lanyard hole **210**. Other structures will be discussed in reference to the various components to which they interact.

Front side **402** of the cutter frame body cutting guide tab **404** formed as a rounded protrusion disposed thereon, with two parallel spaced apart guide retaining walls **406A** and **406B** disposed therebelow. As depicted in FIGS. **5A** and **5B**, cutting guide **225** includes a body **300** that extends upward to contiguously form a C-shaped inner portion **232** and an elongated tail portion **302**. An attachment hole **304** is formed in the lower portion of body **300** and passes therethrough. Cutting guide **225** includes a larger generally C-shaped outer portion **230** disposed on the smaller diameter C-shaped inner portion **232** as depicted in FIG. **3**, upon installation to frame **40**, attachment hole **304** resides on cutting guide tab **404**, with tail portion **302** extending down the length of front face **402** and residing between the guide retaining walls **406A** and **406B**. Inner portion **232** lies adjacent the rotary blade **220**. As best depicted in FIG. **9**, outer portion **230** defines a wall **233** and a guide groove **G** is defined by the gap between wall **233** and rotary blade **220**, with the "floor" of the gap defined by inner portion **232**.

The round shapes of attachment hole **304** and cutting guide tab **404** allow the cutting guide to pivot on the guide tab

during use, while retaining walls **406A** and **406B** determine the maximum extent of the pivot by restraining tail portion **302**. As depicted, the interior portion of blade guide control or cutting depth selector **214**, may be a set of retaining walls **410A** and **410B** disposed on the rear surface of the slidable 5 button. As the cutting depth selector **214** is slidably adjusted, retaining walls **410A** and **410B** move up or down the length of tail portion **302** determining the amount the cutting guide **225** can pivot, and thereby the depth of blade available for cutting by determining the amount of blade **220** that can extend 10 beyond the lower surface of ruler **10** as the guide **110** interacts with the groove **G**, as discussed in additional detail further herein.

FIG. 6, depicts the cutter **20** with rear face **250** removed to allow additional details of the blade guard **252** and other 15 components to be viewed and FIG. 7, depicts rear face **250** of cutter frame **40** and guard lock component **254**. Cutter frame **40** rear side **450** may have a first planar surface **451** at begging at an upper end thereof at rounded top end **401** and extending downwards along the rear side **450** to locking recess **452**, 20 which may be formed as a polygonal recess through the frame **40** above the lanyard hole opening. As depicted, the locking recess **452** as a shape that can be generally described as a large rectangle with a smaller rectangular inset, but it will be appreciated that any desired shape could be used.

A second planar surface **453** which is parallel to the first planar surface **451** is defined by the upper surface of two 25 parallel walls **455A** and **455B** disposed on the opposite edges of rear side **450**, extending from an upper corner **457** downwards to locking recess **452**, where the walls widen to define the edges of the locking recess and merge to set a common thickness through bottom end **403**. The edges of the walls **455A** and **455B** thus define side walls of a recess floored by the first planar surface **451**.

A number of features are disposed on or though the first 30 planar surface **451**. A lock stop recess **468** is formed as an elongated opening with rounded ends place along the midline of frame **40** below axle opening **407**. Outwards from the lock stop recess, the frame **40** extends outwards to form two opposite shoulders, each of which has a stop **470A** or **470B** formed thereon as a raised portion having a sidewall that may extend 35 to an outer surface with that is in a common plane with the second planar surface **453**. Below the these shoulders, the frame **40** may again extend outwards on either side to two rounded members that each have a rounded button recess **464A** or **464B** for the attachment of a guard release button **215**. Downwards from these members, the frame may curve inward and then extend outward to two additional members 40 each of which has a round post **462A** or **462B** disposed thereon. Inwards from these posts **462A**, two mirror image curved slots **460A** and **460B** may be disposed. Above these posts at a midline of the frame, a guard mounting tab **502** is formed as a rounded post disposed on the planar surface. Near the lower end of the recess floored by the first plane **451**, two retaining posts **466A** and **466B** may be disposed spaced apart 45 from one another across the midline of the frame **40**.

Guard stop **254** is slidably placed on the first planar surface **451** in the recess floored thereby, as depicted in FIGS. 6 and 7. A planar rear surface of the guard stop **254** lies adjacent the first planar surface **451** and slides thereon during actuation. A round tab (not depicted) on the rear surface of the guard stop extends into the lock stop recess **468**. The guard stop **254** extends from an, upper end near the top end of the frame **40** downwards to a lower end. A locking tab **500** is formed as a rounded post disposed on the outer surface near the upper 50 end. From the locking tab **500**, the guard stop **254** extends downwards angling out from the midline in a flared wedge

shape to two opposite corners **501A** and **501B**. From the corners, the guard stop **254** cuts inwards the back outward to form two opposite curved surfaces **503A** and **503B** near the curved slots **460A** and **460B**. Above the curved surfaces a mounting opening **552** is formed to allow the guard mounting 5 tab to pass therethrough.

From the curved surfaces **503**, the guard stop **254** extends downwards to the locking recess **452** as a planar member. In the depicted embodiment, the guard stop **254** continues into the locking recess with a recess portion **505** that resides within the recess **452**. Recess portion **505** may have an upper portion that is coplanar with the rear surface of the guard stop and a lower portion that thickens or widens to the thickness of the frame **40**. The recess portion **505** may have a polygonal 10 shape mirroring that of the recess and an opening therethrough to allow a spring **510** or other resilient member to be attached to the frame **40** at the upper end of recess and to guard stop **254** at the lower end of the opening to thereby provide a downwards force on the guard stop **254**.

Recess portion **505** may also include a structure for interacting with the locking selector **212**. In the depicted embodiment, this is an opening **512** that receives a post **213** disposed on the locking selector **212** inner surface on the front surface **201** of case **200**. Depression of the locking selector **212** thus 15 moves the post **213** into and out of the opening **512** to allow slidable movement of the guard stop **254**. Above the recess portion **505**, two parallel openings **507A** and **507B** allow the retaining posts **466A** and **466B** to pass through the body of the guard stop **254**.

Returning to FIG. 6, the guard release buttons **215A** and **215B** each have an oval button portion that extends in line with the body of the frame **40** to be accessible on the side of the cutter **20**. Above the button portion a tab extends in a plane 20 parallel to the frame **40**. A post disposed on this tab is inserted into the round button hole **464** and allows the button to be pressed inward by pivotal rotation. Two generally L-shaped members **520A** and **520B** are disposed on the round posts **462A** and **462B**, with one "leg" of each L contacting each curved surface **503** of the guard stop **254** and the other "leg" extending to the guard release button **215**. Inward movement of a guard release button **215** thus presses on the member **520**, causing it to rotate and extend one leg across the curved surface **503** moving the guard stop **254** slidably upwards. Upon release of the button **215**, the spring **510** returns the 25 guard stop **254** to the lower position.

FIGS. 8A and 8B show some additional details of the blade guard **252**. Blade guard **252** includes a body **600** that extends upward to form circular or rounded upper end that is slightly larger than the rotary blade **220**. Moving downwards, the body **600** tapers inwards, has inset recesses **603**, which correspond to the opening in the handle top surface, and then has an elongated tail portion **612**. An attachment hole **610** is formed in the lower portion of body **600** and passes through. Above attachment hole **610**, a locking opening **608** has a lower locking portion that is sized to receive locking tab **500** and an larger upper portion that extends transversely 30 outwards to rounded ends. Above locking opening **608**, axle opening **606** is formed as a generally transverse elongated opening with rounded ends. On the inner surface of the blade guard **252** a wall **604** is disposed around the periphery of the upper end to extend past the frame **40** to a position adjacent the blade **220**, when installed.

As depicted in FIG. 6, upon installation to frame **40**, attachment hole **610** resides on guard mounting tab **502**, with tail portion **612** extending down the length of the frame **402** and residing between the retaining posts **466A** and **466B**. Similarly, locking tab **500** resides in locking opening **608**. The 35

round shapes of attachment hole **610** and cutting guide tab **404** allow the blade guard **252** to pivot on the mounting tab **502** during use, when the locking tab **500** is moved from the lower portion of the locking opening to the upper portion. As pressure is applied to the wall **604** to make a cut, the blade guard pivots, the upper portion of locking opening **608** and the axle opening **606** move with respect to the locking tab **502** and the axle bolt **222** and the edge of the blade **222** is exposed.

FIG. 9 depicts some additional details of the cutting portion **208**. Axle bolt **222** passes through the blade **220** and central passage **239** of the cutting guide **230**. The wall **233** defined by the outer portion **230** of cutting guide **230** defines a guide groove G formed by the gap between wall **233** and rotary blade **220**, with the "floor" of the groove defined by the transverse wall **235** of inner portion **232**. As depicted in FIG. 10, when a cut is made with the rotary cutter **20** and ruler **10**, the groove G may be placed over the ridge **110** along the ruler **10** cutting edge. The ridge top surface **112** may reside on or near the transverse wall **235** surface of inner portion **232** and blade **220** lies against the outer sidewall **115** of the ridge **110**, outer portion **230** lies adjacent inner sidewall **111** with curved outer surface **237** over the ruler **10** upper surface **101**. This placement of groove G over the cutting ridge thus prevents the cutter **20** from straying away from the ruler **10** during cutting.

Although the guide ridge **230** is depicted herein as having a generally rectangular cross sectional shape with a rounded upper inside corner and groove G is depicted as having a generally rectangular cross section defined by wall **233** and rotary blade **230**, it will be appreciated that these cross-sectional profiles may vary in order to allow different blades types, rulers with curved shapes or more secure connections to be made. For example, a where a protrusion is formed on the inner sidewall **111** of the guide ridge **110** and a corresponding slot is formed on the surface of the wall **233**, this could add an additional point of securement for the cutter **20**. Such variance could also allow for the accommodation of different guides.

It will be appreciated that in addition to ruler **10** disclosed herein, that it may be possible to adapt preexisting rulers lacking a ridge **110** along the ruler cutting edge to work as part of a system in accordance with the present invention. For example, a ridge **110** may be marketed as a stand-alone piece that may be attached to the upper surface of an existing ruler along the cutting edge thereof. Such a ruler could then be used with the hand held rotary cutter **20** disclosed herein and obtain a portion of the benefits of the present invention.

Additionally, it is noted that cutter **20** and ruler **10** are discussed above as separate tools that are used together in a system in accordance with the present invention, but each is also capable of use with other rulers and cutters. It will be appreciated that in some systems in accordance with the present invention, cutter **20** may be securely fixed to the ruler, having a differently designed handle to prevent inadvertent removal. Such a handle could be configured to allow for either left or right handed use.

While the present invention has been shown and described in terms of preferred embodiments thereof, it will be understood that this invention is not limited to any particular embodiment and that changes and modifications may be made without departing from the true spirit and scope of the invention as defined and desired to be protected.

What is claimed is:

1. A system for cutting sheet materials comprising: a ruler for use with a rotary cutting tool, the ruler comprising a body with a planar section having an upper surface and a lower surface and a guide ridge disposed along an edge of the body, the guide ridge comprising an inner

sidewall that extends from the upper surface to a ridge top surface and an outer sidewall extending from the ridge top surface to the lower surface; and a hand held rotary cutting tool comprising a handle and a cutting portion, the cutting portion comprising a rotary blade having two parallel faces and a generally circular cutting edge, an axle passing through rotary cutting blade, a retainer disposed on the axle to secure the rotary cutting blade to the handheld rotary cutting tool, and a blade guide comprising a larger portion and a smaller inner portion attached to the larger portion and adjacent to a first parallel face of the rotary blade, the larger portion defining a curved outer surface which is positioned between and abuts a top surface of the smaller inner portion and a bottom surface of the retainer to define a groove, such that when the groove is placed over the guide ridge an edge of the rotary blade is placed in a position adjacent to the outer sidewall of the guide ridge with the curved outer surface adjacent to the inner sidewall of the guide ridge.

2. The system of claim 1, wherein the ruler further comprises length marking indicia formed as a series of bumps disposed on the lower surface.

3. The system of claim 1, wherein the length marking indicia comprises a set of markings that form a grid pattern on the ruler.

4. The system of claim 1, wherein the planar section of the ruler includes multiple openings passing through the body from the upper surface to the lower surface.

5. The system of claim 1, wherein the inner portion and the larger portion of the blade guide are each generally C-shaped members.

6. The system of claim 1, wherein the blade guide further comprises a blade depth control by having the deflection with respect to the rotary blade able to be altered by a user to set the depth of the portion of rotary blade extending past the lower surface of the ruler during use.

7. The system of claim 6, wherein the blade guide deflects with respect to the rotary blade by pivoting on the rounded post on a frame of the hand held rotary cutter.

8. The system of claim 6, wherein the deflection with respect to the rotary blade of the blade guide that can be altered by a user is set by a pair of parallel walls that are slidably moved within the handle of the rotary cutting tool along the length of a tail portion of the blade guide.

9. The system of claim 1, wherein the hand held rotary cutting tool cutting portion comprises a deflectable blade guard with a rounded upper end that is slightly larger than the rotary blade and has a wall that is positioned adjacent the rotary blade.

10. The system of claim 9, wherein the blade guard deflects with respect to the rotary blade by pivoting on a rounded post on the frame of the hand held rotary cutter.

11. The system of claim 9, wherein the deflectable blade guard is maintained in a locked position such that it does not deflect away and expose the rotary blade unless unlocked by a user.

12. The system of claim 11, wherein the deflectable blade guard is unlocked by a user depressing a release button to slidably move a locking tab from a recess on the blade guard.

13. The system of claim 11, wherein the deflectable blade guard is unlocked by a user depressing a release button to withdraw a post from a slidably moveable guard stop which interacts with the blade guard.

14. The system of claim 1, wherein the blade guide comprises a larger portion and a smaller inner portion attached to

the larger portion and adjacent to a first parallel face of the rotary blade, the larger portion defining a curved outer surface which is positioned between and abuts a top surface of the smaller inner portion and a bottom surface of the retainer to define a groove, such that when the groove is placed over the guide ridge the blade guide allows the handle of the hand held rotary cutting tool to be placed at various angles with respect to the ruler while maintaining the guide ridge within the groove.

15. The system of claim 1, wherein the blade guide is monolithic.

16. A hand held rotary cutting tool system comprising: a ruler for use with a rotary cutting tool, the ruler comprising a body with a planar section having an upper surface and a lower surface and a guide ridge disposed along an edge of the body, the guide ridge comprising an inner sidewall that extends from the upper surface to a ridge top surface and an outer sidewall extending from the ridge top surface to the lower surface; and

- a hand held rotary cutting tool comprising a handle;
- a frame disposed at least partially within the handle; and
- a cutting portion disposed at one end of the handle, the cutting portion comprising
 - a rotary blade having two parallel faces and a generally circular cutting edge rotatably mounted on a portion of the frame extending beyond the handle,
 - an axle passing through rotary cutting blade,
 - a retainer disposed on the axle to secure the rotary cutting blade to the handheld rotary cutting tool, and
 - a blade guide comprising a larger portion and a smaller inner portion attached to the larger portion and adjacent to a first parallel face of the rotary blade, the larger portion defining a curved outer surface which is positioned between and abuts a top surface of the smaller inner portion and a bottom surface of the retainer to define a groove which corresponds to the guide ridge disposed on a cutting edge of the ruler, such that when the groove is placed over the guide ridge an edge of the rotary blade is placed in a position adjacent to the cutting edge of the ruler with the curved outer surface adjacent to the guide ridge.

17. The hand held rotary cutting tool system of claim 16, wherein the smaller inner portion and the larger outer portion of the curved blade guide are each generally C-shaped members.

18. The hand held rotary cutting tool system of claim 16, wherein the blade guide deflects with respect to the rotary blade by movement of the blade guide in a direction parallel to the first parallel face of the rotary blade.

19. The hand held rotary cutting tool system of claim 18, wherein the curved blade guide further comprises a blade depth control by having the deflection with respect to the rotary blade able to be altered by a user to set the depth of the portion of rotary blade extending past the lower surface of the ruler during use.

20. The hand held rotary cutting tool system of claim 19, wherein the curved blade guide deflects with respect to the rotary blade by pivoting on a rounded post on the frame of the hand held rotary cutter and the deflection with respect to the rotary blade of the blade guide can be altered by slidably moving a pair of parallel walls within the handle of the rotary cutting tool along the length of a tail portion of the curved blade guide.

21. The hand held rotary cutting tool system of claim 16, wherein the hand held rotary cutting tool cutting portion

comprises a deflectable blade guard with a rounded upper end that is slightly larger than the rotary blade and has a wall that is positioned adjacent the rotary blade.

22. The hand held rotary cutting tool system of claim 21, wherein the blade guard deflects with respect to the rotary blade by pivoting on a rounded post on the frame of the hand held rotary cutter.

23. The hand held rotary cutting tool system of claim 21, wherein the deflectable blade guard is maintained in a locked position such that it does not deflect away and expose the rotary blade unless unlocked by a user depressing a release button to slidably move a locking tab from a recess on the blade guard.

24. The hand held rotary cutting tool system of claim 21, wherein the deflectable blade guard is unlocked by a user depressing a release button to withdraw a post from a slidably moveable guard stop which interacts with the blade guard.

25. The hand held rotary cutting tool system of claim 16, wherein the blade guide is monolithic.

26. A hand held rotary cutting tool comprising:
- a handle;
 - a frame disposed at least partially within the handle; and
 - a cutting portion disposed at one end of the handle, the cutting portion comprising
 - a rotary blade having two parallel faces and a generally circular cutting edge rotatably mounted on a portion of the frame extending beyond the handle,
 - an axle passing through rotary cutting blade,
 - a blade guide including a central passage through which the axle passes and comprising a member with a smaller inner portion adjacent to a first parallel face of the rotary blade to define a transverse wall that is generally perpendicular to the first parallel face of the rotary blade and a larger outer portion disposed on the smaller inner portion to form a guide sidewall generally parallel to the first parallel face of the rotary blade such that a groove is defined by a gap between the guide sidewall and the first parallel face of the rotary blade which corresponds to a guide ridge disposed on a cutting edge of a ruler, such that placing the groove over the guide ridge will place the rotary blade in a position adjacent to the cutting edge of the ruler with the transverse wall of the blade guide over the guide ridge and the larger outer portion adjacent the guide ridge and the blade guide deflects with respect to the rotary blade by movement of the blade guide in a direction parallel to the first parallel face of the rotary blade and away from a long axis of the handle, wherein the inner portion and the larger outer portion of the blade guide are each generally C-shaped members, and

a retainer disposed on the axle to secure the rotary cutting blade to the handheld rotary cutting tool.

27. The hand held rotary cutting tool of claim 26, wherein the blade guide further comprises a blade depth control by having the deflection with respect to the rotary blade able to be altered by a user to set the depth of the portion of rotary blade extending past the lower surface of the ruler during use.

28. The hand held rotary cutting tool of claim 26, wherein the blade guide deflects with respect to the rotary blade by pivoting on a rounded post on a frame of the hand held rotary cutter and the deflection with respect to the rotary blade of the blade guide can be altered by slidably moving a pair of parallel walls within the handle of the rotary cutting tool along the length of a tail portion of the blade guide.