

Mini Quilter

TABLETOP FABRIC FRAME

ASSEMBLY AND USE INSTRUCTIONS

Included Parts & Tools

Top Plate

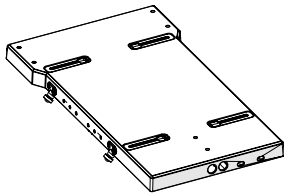

MQT-09-17757

Bottom Carriage

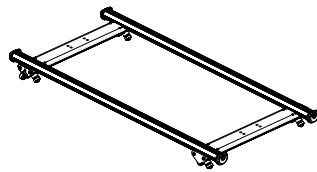

MQF-09-18720

Side Wall (Left)

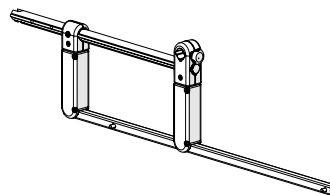

MQF-09-18719

Side Wall (Right)

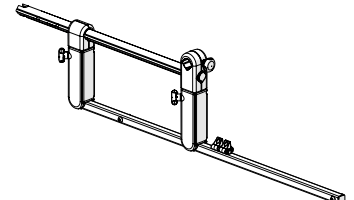

MQF-09-18726

Front Rail

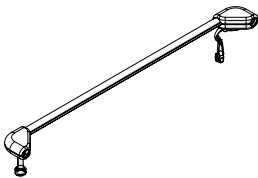

MQF-09-18728

Frame Track (x2)



MQF-09-18675

Take-Up Rail

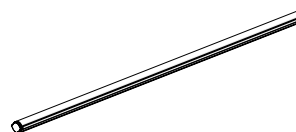

MQF-09-18672

Mini-Quilter Handle (x2)

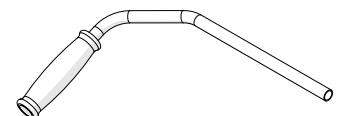

MQF-09-18850

**Front/Side Clamp (x4)
(Shipped on Rails)**

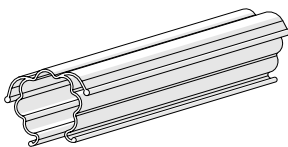

MQF-05-18671

**Take-Up Clamp (x2)
(Shipped on Rail)**

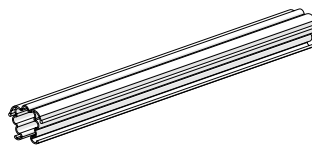

MQF-05-18670

**Elastic Clip (x2)
(Shipped on Rail)**



MQF-09-18724

Practice Grid

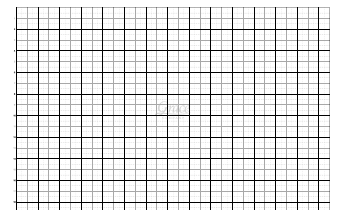

MQF-08-18773

Hardware Box

Placement Template

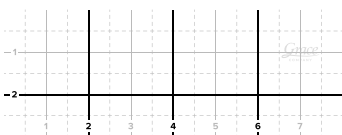

MQF-08-18772

Sewing Machine Clamps (x4)

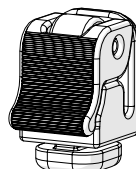

ACC-01-10324

**Elastic Clip
(Removable)**

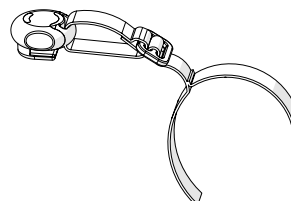

MQF-09-18851

**SBHCS
M4 x 25 mm (x2)**

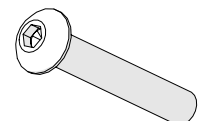

HDW-03-12240

Hardware Box (cont.)

SBHCS
M4 x 11 mm (x2)

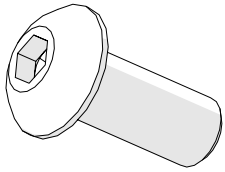

HDW-03-18856

Allen Wrench 2.5 mm

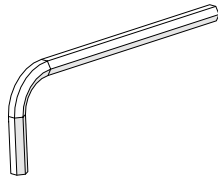

HDW-03-10165

Allen Wrench 4 mm

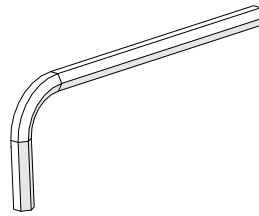

HDW-03-10167

Zip Tie (x2)

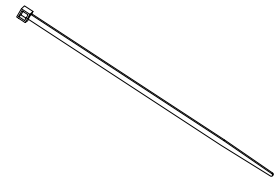

MIS-08-10804

Zip Tie Mount

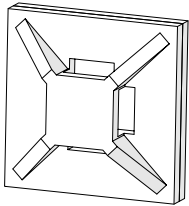

MIS-08-10805

Contents

Included Parts & Tools.....	1	Task 10 - Preparing Your Sewing Machine for Quilting.....	14
Task 1 - Removing the Fabric Clamps	3	Task 11 - Preparing Your Quilt Sandwich.....	15
Task 2 - Adjusting the Side Rails.....	3	Task 12 - Attaching Your Quilt	16
Task 3 - Attaching the Side Walls to the Tracks	4	Task 13 - Testing Your Fabric Tension	19
Task 4 - Aligning the Tracks Using the Bottom Carriage	6	Task 14 - Marking Your Quiltable Area	19
Task 5 - Attaching the Handles to the Top Plate....	7	Task 15 - Using the Elastic Clips	21
Task 6 - Installing the Machine on the Top Plate ...	7	Task 16 - Starting & Ending Your Designs	21
Task 7 - Attaching the Front Rail.....	9	Task 17 - Tacking Down the Quilt Top Edges	24
Task 8 - Installing the Take-Up Rail & Adjusting Its Location	10	Task 18 - Moving Your Quilt to a Different Zone..	24
Task 9 - Managing the Foot Pedal Cable.....	12	Task 19 - Using Additional Resources.....	26
Route Cable from Back	13	Design Tracing Paper	26
Route Cable from Front.....	13	Letter-Paper Sized Practice Grid	26
		Placement Template	26
		Notes	30

Task 1 - Removing the Fabric Clamps

Parts & Tools Needed: Side Wall (Left & Right); Front Rail; Take-Up Rail

To remove the fabric clamps from the rails:

- 1 Locate both **side walls**, the **front rail**, and the **take-up rail**.

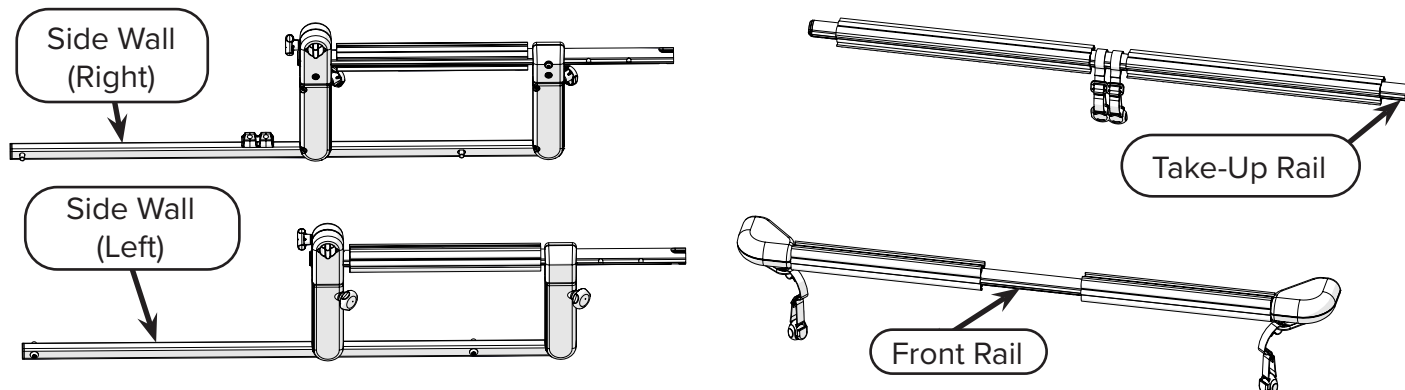

- 2 Pull off the fabric **clamps** (both the take-up clamps and the front/side clamps) and set them aside to use later. **Note:** It can help to focus on one end of a clamp at a time, rather than trying to pull them off from the middle.

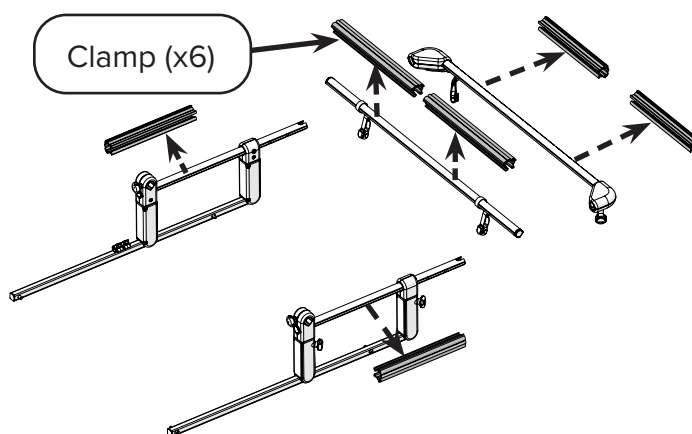

Task 2 - Adjusting the Side Rails

Parts & Tools Needed: 2.5 mm Allen Wrench; SBHCS M4 x 11 mm (x2)

To adjust the rails on the side walls to the right length for your machine:

- 1 Measure the length of your machine and write down the number.

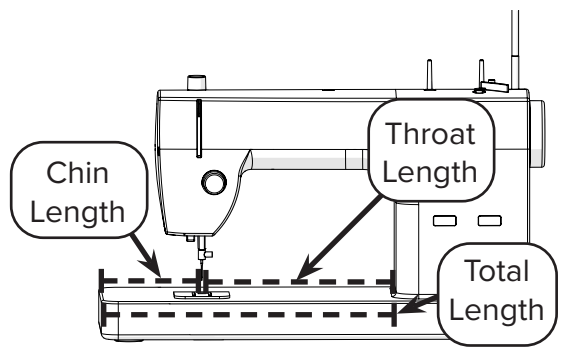

Note: You need to measure the **full length** of your machine, not just the **throat length**. You must also include any **chin length** your machine might have.

- For *both* side rails, slide the **rail** until the correct **notch** lines up with the **screw hole**. Use the measurement from earlier and the table to determine which notch is correct. The notches are marked with letters. Set both side rails to the same notch.

Note: Don't remove the rail from the side wall! This view is just to help you understand where the notches are on the rails.

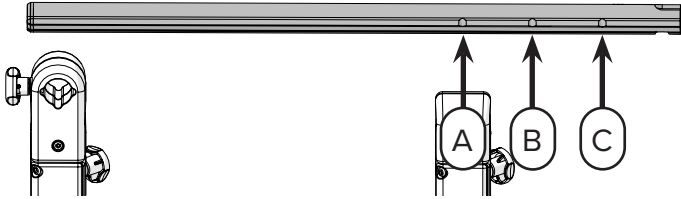

Full Length of Machine	Hole on Rails
14 in. or less	C
14 1/8 in. to 16 in.	B
16 1/8 in. to 20 in.	A

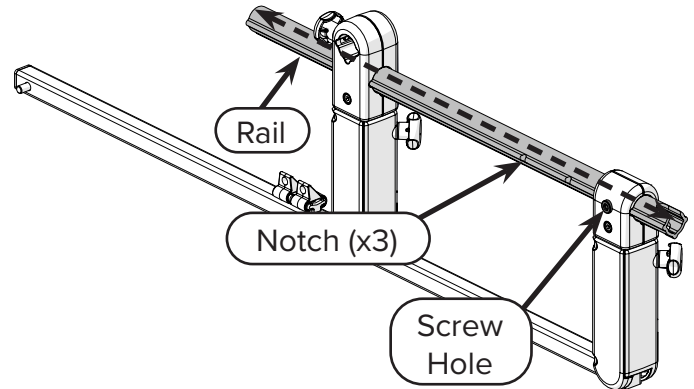

- For *each* side rail, use the 2.5 Allen wrench to tighten an **M4 x 11 mm SBHCS** in the screw hole to hold the rail in place.

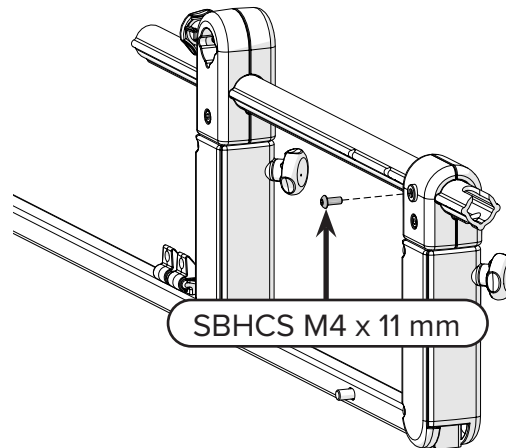
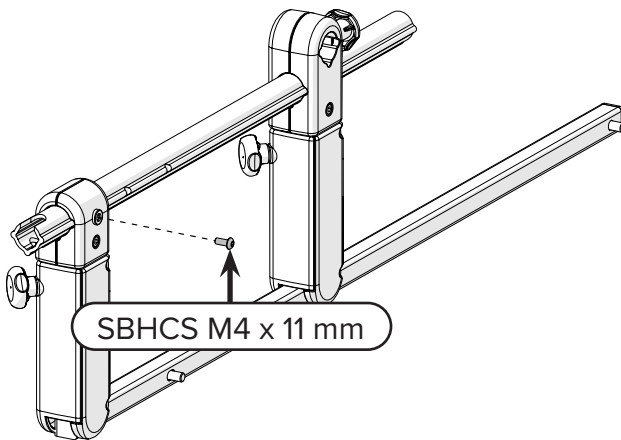

Task 3 - Attaching the Side Walls to the Tracks

Parts & Tools Needed: Side Wall (Left & Right); Plastic Track (x2); 4 mm Allen Wrench

To attach the side walls to the plastic tracks:

- Set the **tracks** parallel to each other.

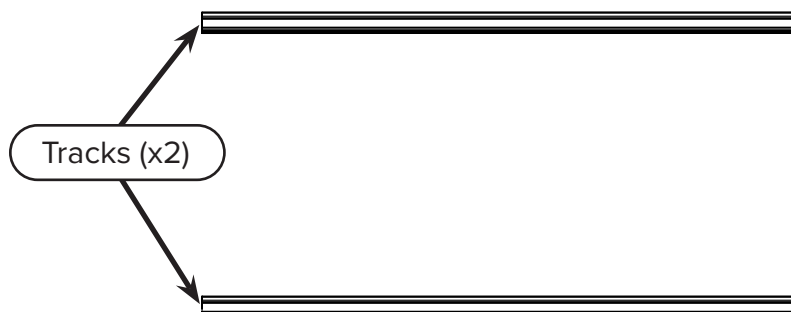

- 2 Put each **side wall** on the matching side of the tracks, and align the holes in the tracks with the **screws** in the side walls. **Note:** The right side wall has two little **mounts** on it for use with the bungee clamp accessory. For more details, visit graceframe.com.

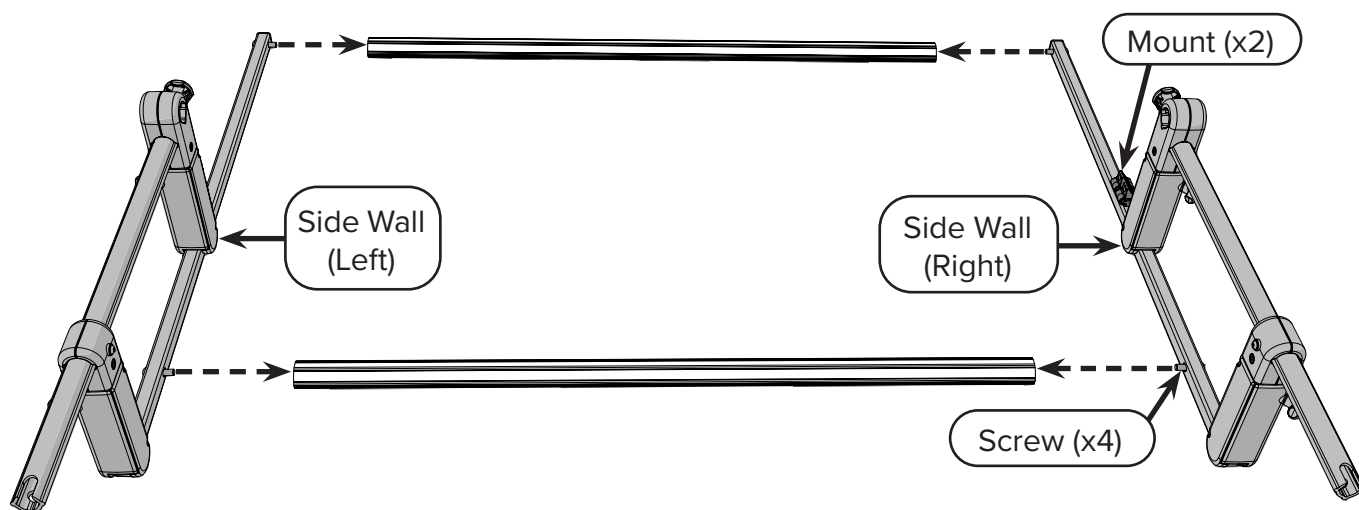

- 3 On the **back** of each side wall, use the 4 mm Allen wrench to *fully* tighten the **screws** so the side walls are secured to the track.

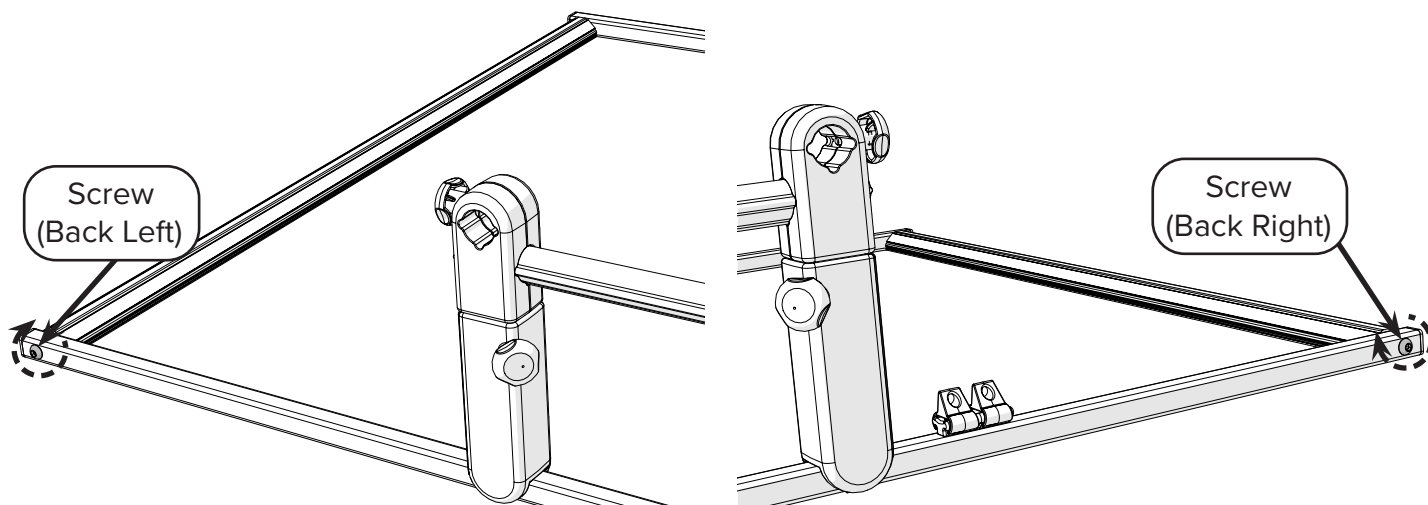

- 4 On the **front** of each side wall, use the Allen wrench to *loosely* tighten the **screws** attaching the side walls to the track. You will fully tighten the screws in the next task.

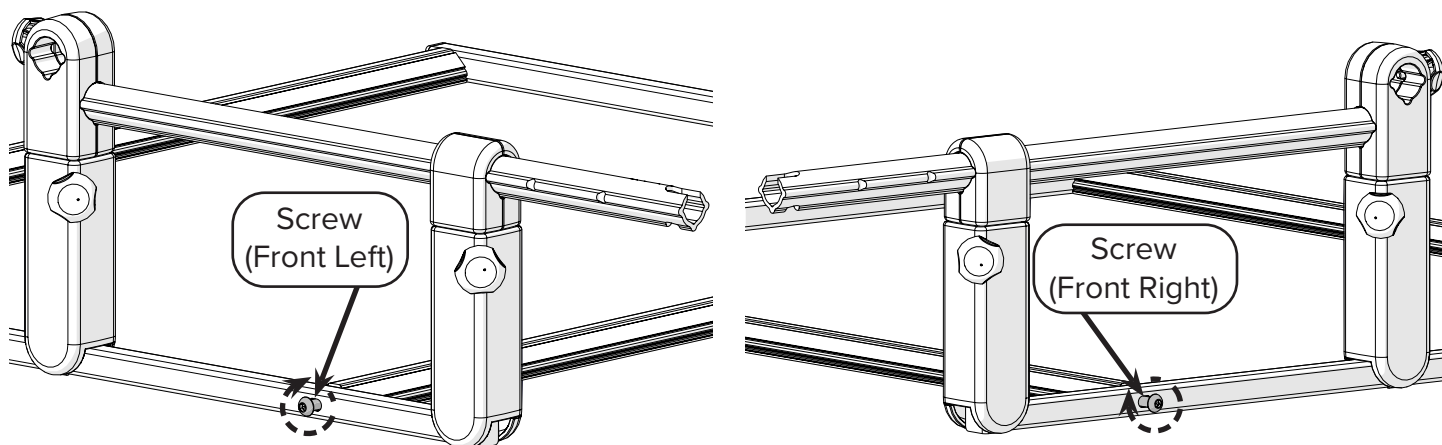

Task 4 - Aligning the Tracks Using the Bottom Carriage

Parts & Tools Needed: Bottom Carriage; 4 mm Allen Wrench

To align the tracks using the bottom carriage:

- 1 Set the **bottom carriage** on the tracks. Make sure each **wheel set** straddles its track.

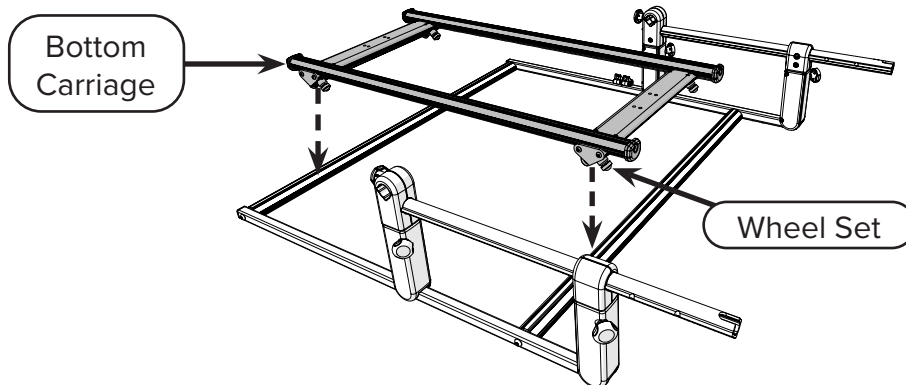

- 2 Move the carriage as far to the left as possible, then as far to the right as possible. Do this motion *a few times*, until you're confident the carriage moves smoothly and evenly on the tracks.

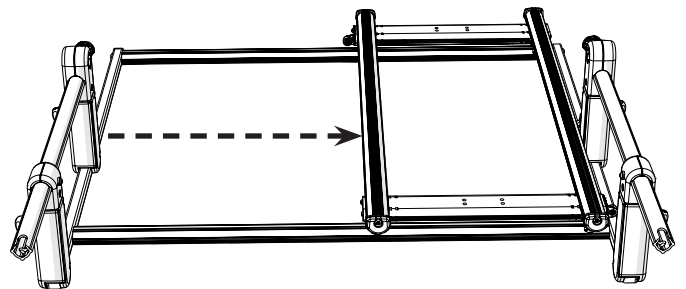
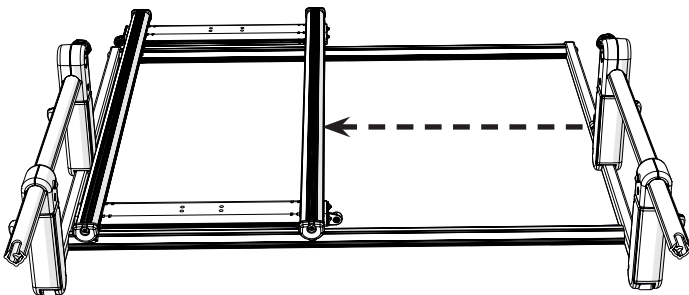

- 3 Make sure the carriage is all the way to the right. Use the 4 mm Allen wrench to tighten the **screw** on the right side wall.

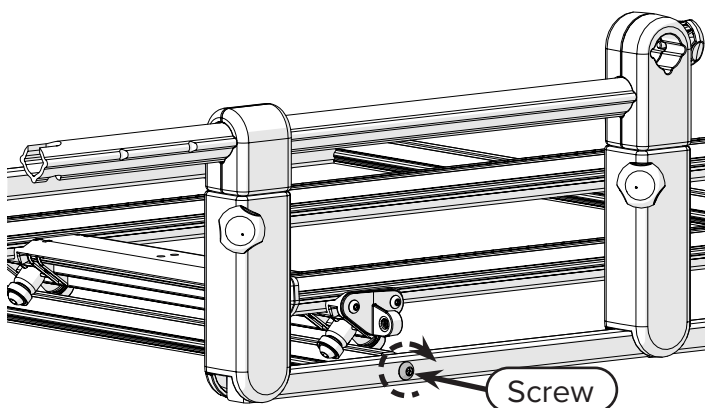

- 4 Move the carriage all the way to the left. Tighten the **screw** on the left side wall.

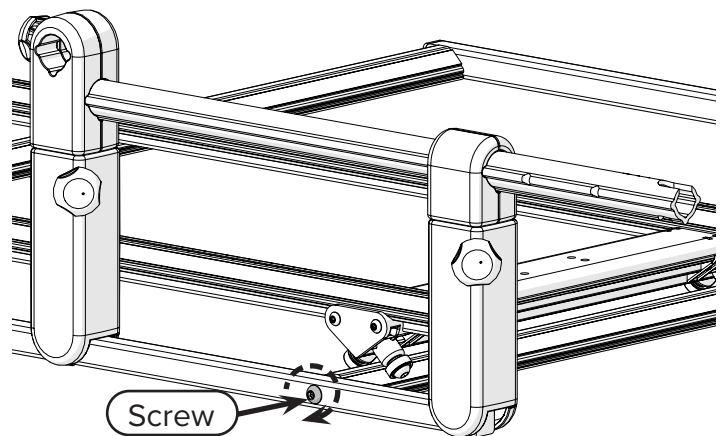

Task 5 - Attaching the Handles to the Top Plate

Parts & Tools Needed: Top Plate; Handles (x2); 2.5 mm Allen Wrench

To attach the handles to the top plate:

- 1 Near the front of the **top plate**, use the 2.5 mm Allen wrench to *loosen* the **screws** holding the **handle clamp** in the top plate.

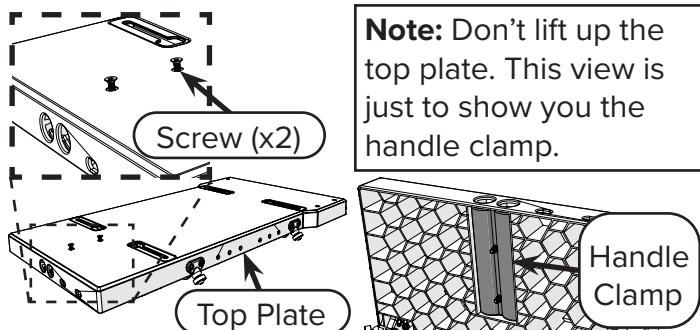

- 2 Slide the **handles** into the round **holes** in the front of the top plate.

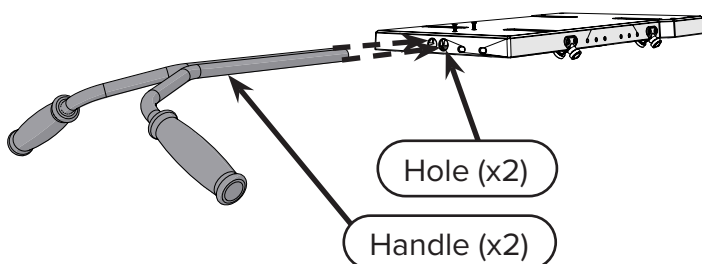

- 3 Use the Allen wrench to re-tighten the screws to hold the handles in the top plate.

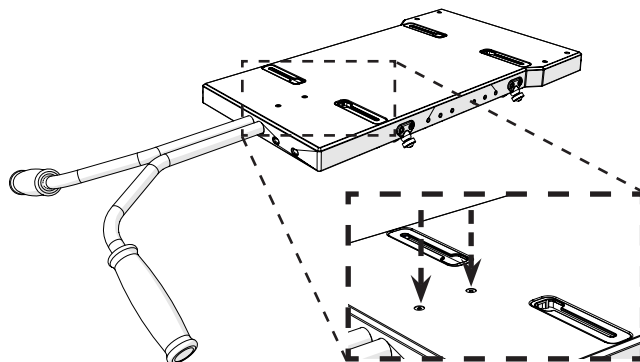

- 4 Grasp the handles and adjust them to the angle you find most comfortable.

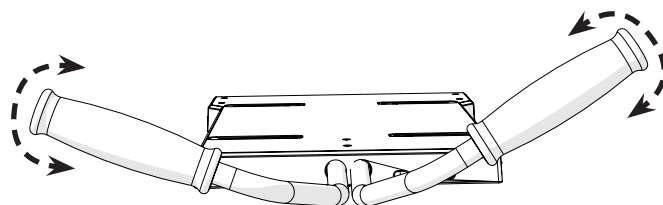

Tip: As you are quilting, if you find yourself stretching a lot to reach the handles, then adjust the position of the handles in the top plate. Loosen the screws, pull the handles out to a comfortable position, and then tighten the screws. Pay attention: if you pull the handles out too far, the clamp won't hold them!

Task 6 - Installing the Machine on the Top Plate

Parts & Tools Needed: Assembled Top Plate; Sewing Machine Clamps (x4); Machine (not included)

To install your machine on the top plate:

- 1 Place the **top plate** so the wheels ride the bottom carriage tracks. Make sure the handles are toward the front of the frame.

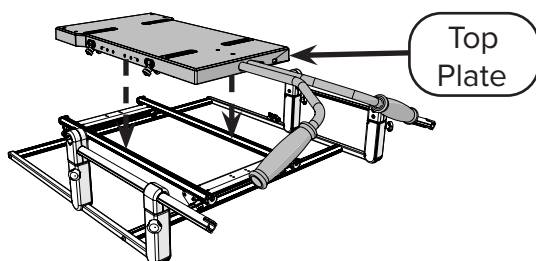

Note: Put your frame on a table before you install your machine.

- 2 Open the four **sewing machine clamps** and place them into the **slots** in the top plate. Make sure the **rubber pads** face toward the center of the top plate.

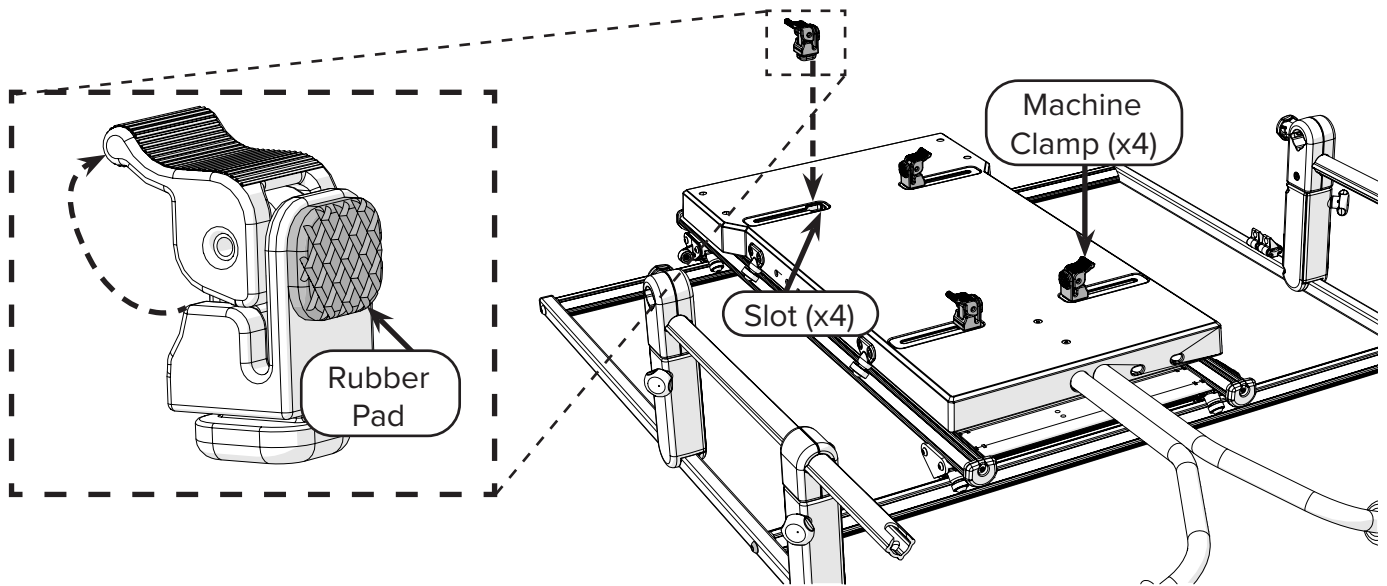

- 3 Slide the sewing machine clamps toward the outer edge of the top plate.

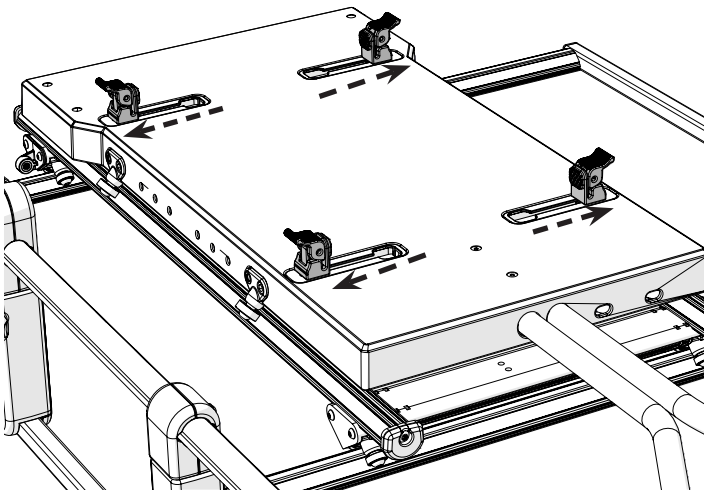

- 4 Place your **machine** on the top plate, centered between the machine clamps.

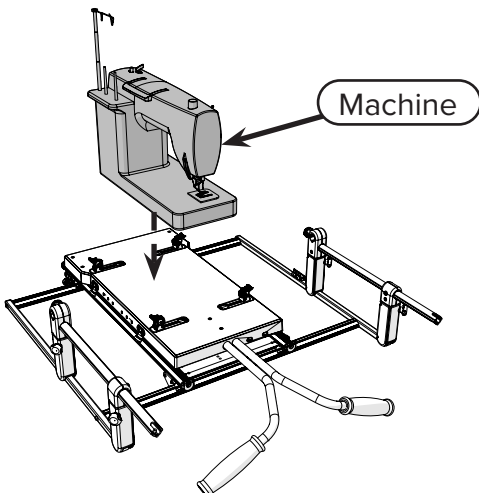

Note: If you can't set your machine on the top plate with all four clamps in place, use fewer clamps.

- 5 Move the sewing machine clamps close to the machine, leaving a small **gap** between the clamps and the machine.

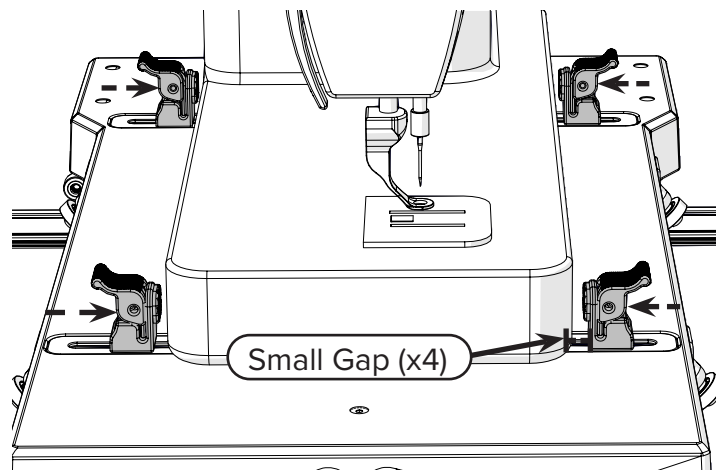

- 6 Close the clamps. They now press up against the machine. **Note:** If the clamps don't press up against the machine, open them back up, move them slightly closer to the machine, and close the clamps again.

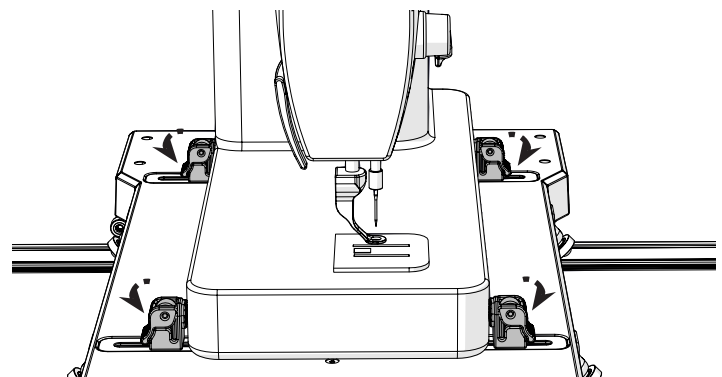

Task 7 - Attaching the Front Rail

Parts & Tools Needed: Front Rail; SBHCS M4 x 25 mm (x2); 2.5 mm Allen Wrench

To attach the front rail:

- 1 Slide the **front rail** onto the side rails. Make sure that the **elastic clips** are on the bottom.

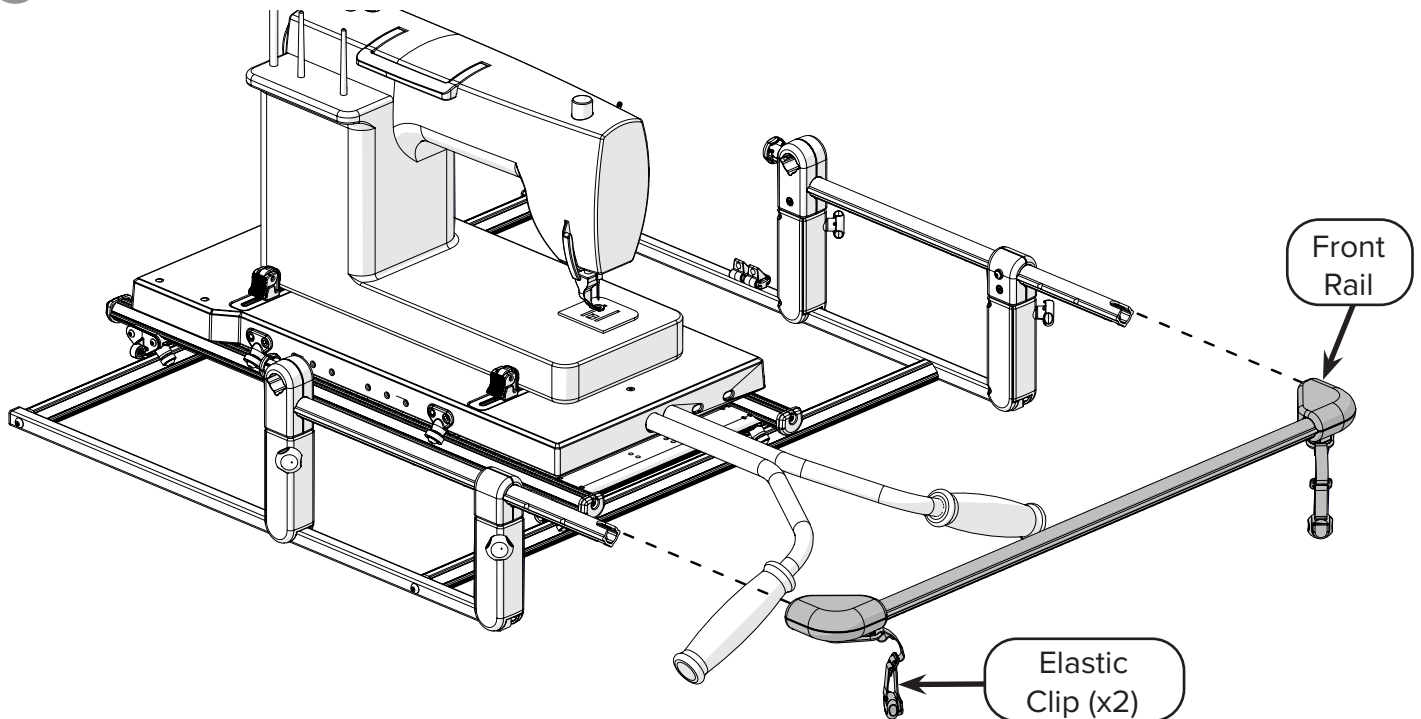

- 2 From the underside, secure the front rail to the side rails using the 2.5 mm Allen wrench and two **M4 x 25 mm SBHCS**.

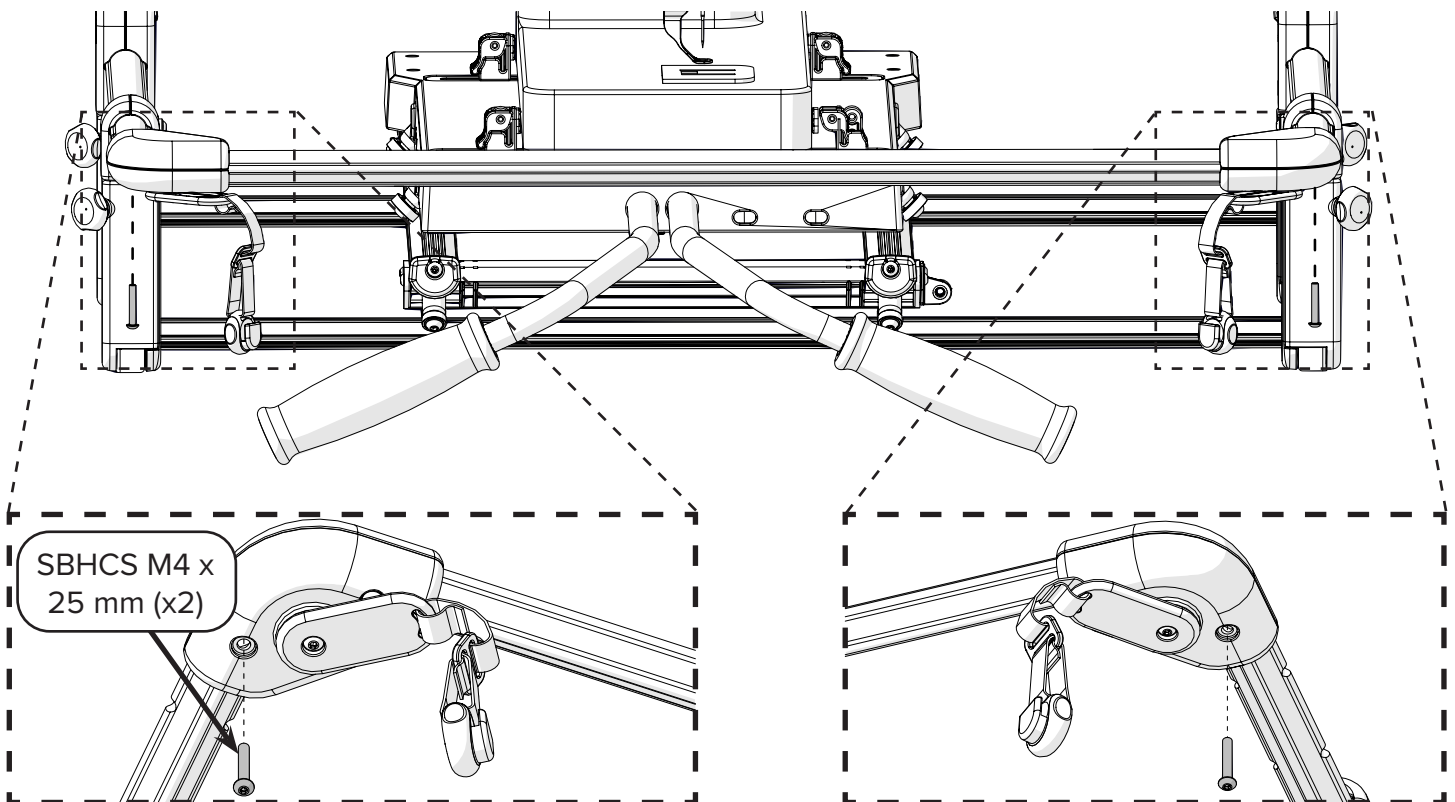

Task 8 - Installing the Take-Up Rail & Adjusting Its Location

Parts & Tools Needed: Take-Up Rail; Take-Up Rail Clamp

The take-up rail must be as close as possible (without touching) to the bed of your machine. However, the clamps on the take-up rail affect how close the rail is to the bed of the machine. Therefore, as you install the take-up rail, you must also confirm the height of the rail holders. They might need to be adjusted to make sure the take-up rail is in the correct location.

To install the take-up rail and adjust its location:

- 1 Twist the four **knobs** on the side rail **towers** to allow the upper half of the towers to move freely.

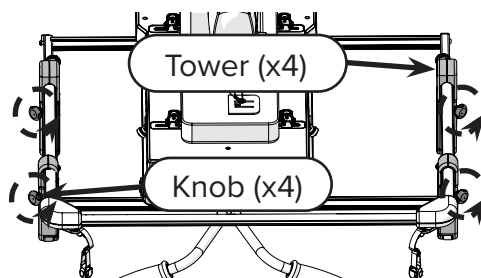

- 2 From the right side of the frame, slide the **take-up rail** into the **throat** of the machine. Make sure the **hooks** on the elastic clips are on the back side of the rail.

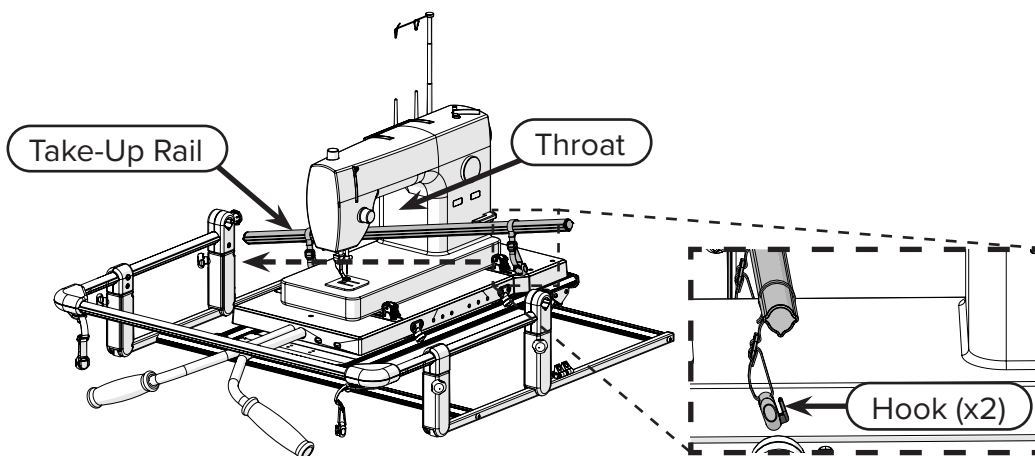

- 3 Insert the end of the take-up rail into the **hole** in the left take-up rail holder, and then insert the other end into the **hole** in the right take-up rail holder. **Note:** You might need to lift the towers as you put the rail in, so that the take-up rail can stay above the machine bed.

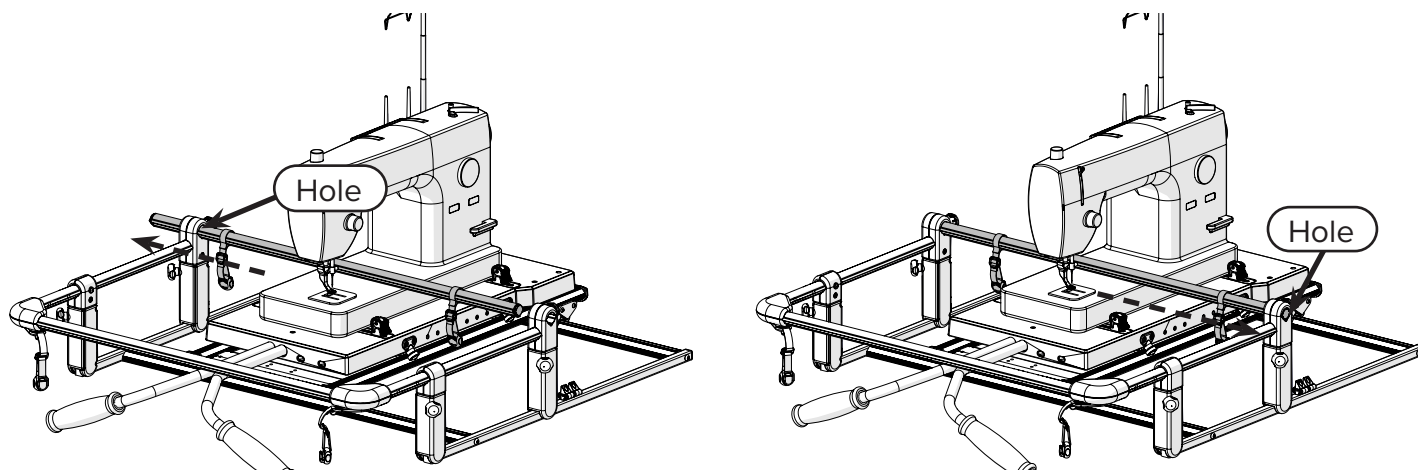

- 4 Tighten the **knobs** on the back of each take-up rail holder to secure the take-up rail.

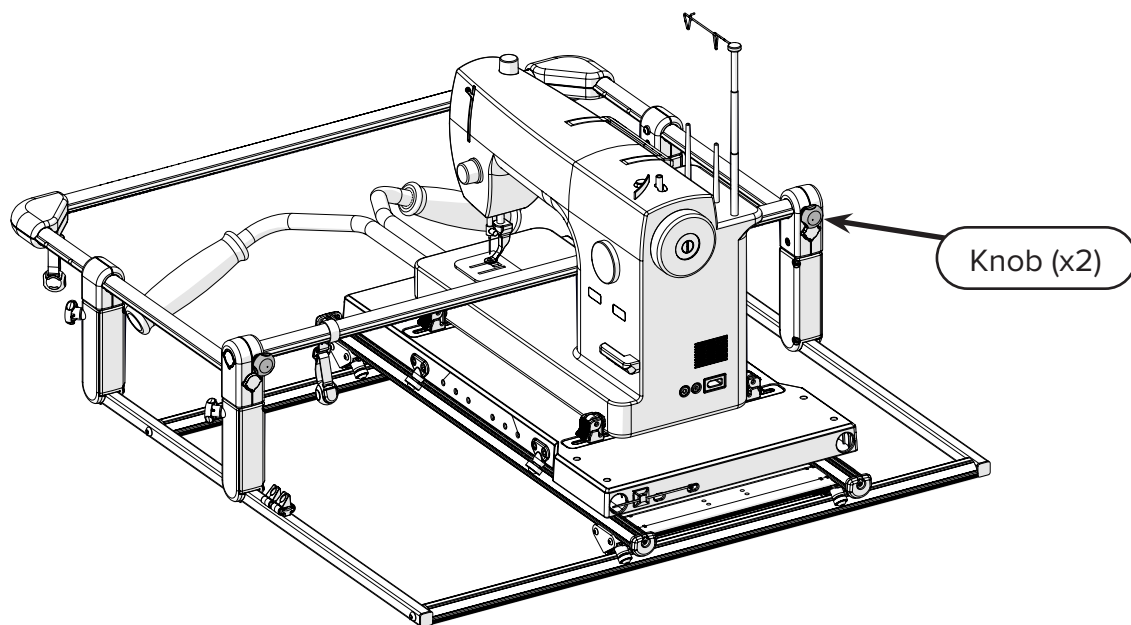

- 5 Put a **take-up clamp** on the take-up rail.

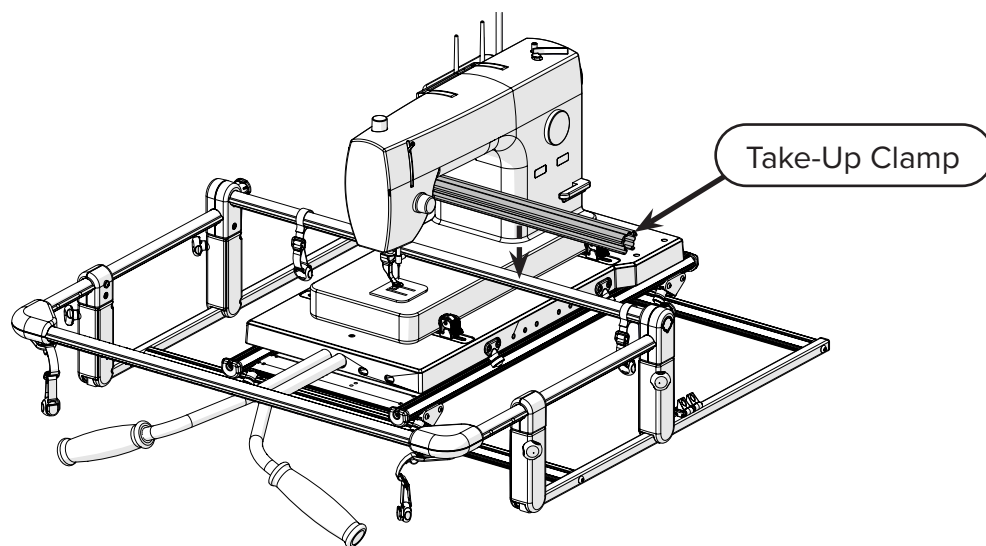

- 6 Move the machine to the right. Lift the right **take-up rail holder** tower so the machine can *just* slide under the clamp on the take-up rail. Note the number of the **notch** on the tower. Tighten the **knob** to set the height of the rail holder.

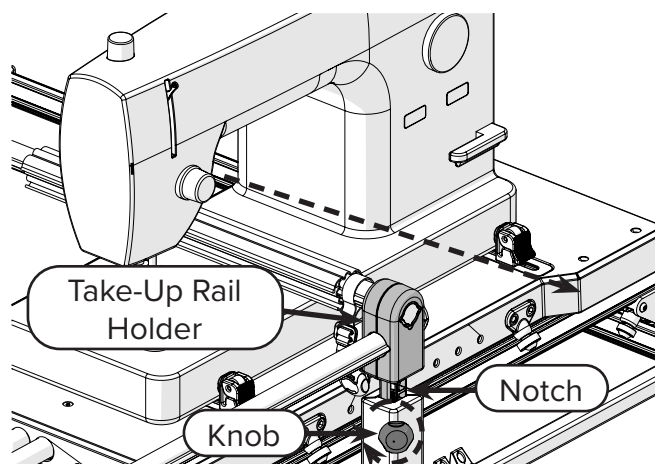

- 7 Set the other **rail holder towers** to the same notch and tighten the knobs to set their height.

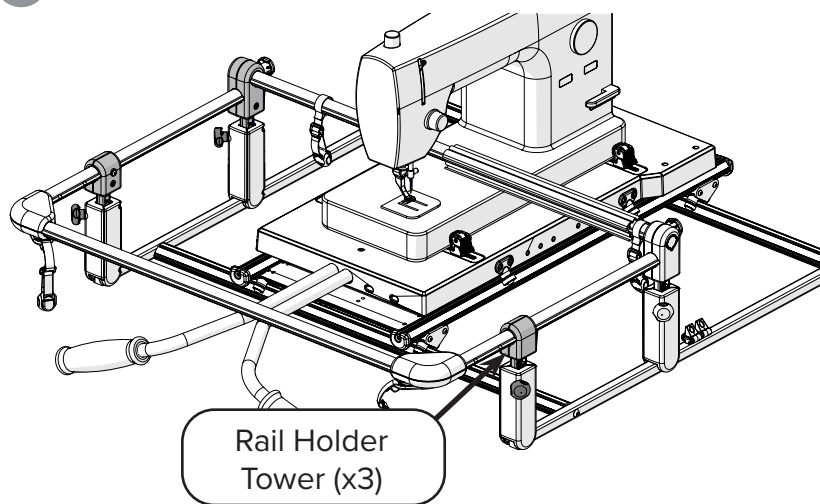

Note: If while you're quilting, you notice the machine is dragging, it might be because the machine is barely touching the take-up rail or the clamp. If this happens, adjust the take-up rail to be slightly farther away from the bed of the machine.

Task 9 - Managing the Foot Pedal Cable

Parts & Tools Needed: Zip Tie (x2); Zip Tie Mount; Measuring Tape or Ruler (not included)

To provide your machine with the full range of motion on the frame without the foot pedal moving out of your reach, you need to place your frame on a work surface that is 23–26 inches deep. This depth is ideal because most foot pedal cables are long enough to be routed from the back of the machine and still reach the floor.

If your work surface is deeper than 26 inches or not accessible from the back, you can probably still use it with the Mini-Quilter. First, try routing the cable from the front, as described in this task. Or, if the work surface is height-adjustable, then lower the height, as a shorter height can offset the extra depth. Another way you can still use the deeper work surface is if you have a long foot pedal cable (longer than 5 feet), which might allow the cable to still reach the floor (from the back or the front) even with the extra depth.

If you find that your work surface and foot pedal cable don't provide you with the range of motion you want, try a different work surface, or contact your machine's manufacturer about any cable extension options they might offer.

To manage the foot pedal cable of your machine on the frame:

Examine and measure your work surface. Decide which of these options best matches your work surface, and then follow the steps in the matching section:

- 23–26 inches deep AND accessible from the back. See "Route Cable from Back".
- Deeper than 26 inches OR not accessible from the back. See "Route Cable from Front".

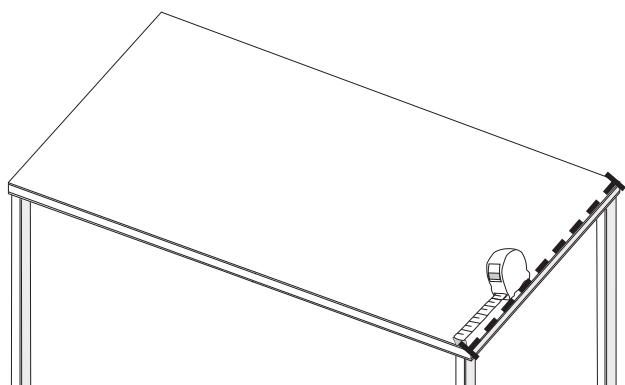

Note: While you're adjusting your machine's location, if you can't set your machine flush with the edge of the top plate and still use all four machine clamps, then either move the machine a bit toward the center of the top plate again, or use fewer clamps. You'll have to decide which option is better for you. (This note applies in Step 2 if routing from the back, or Steps 2 & 4 if routing from the front.)

Route Cable from Back

- 1 Line up the back of the frame with the back edge of the table.

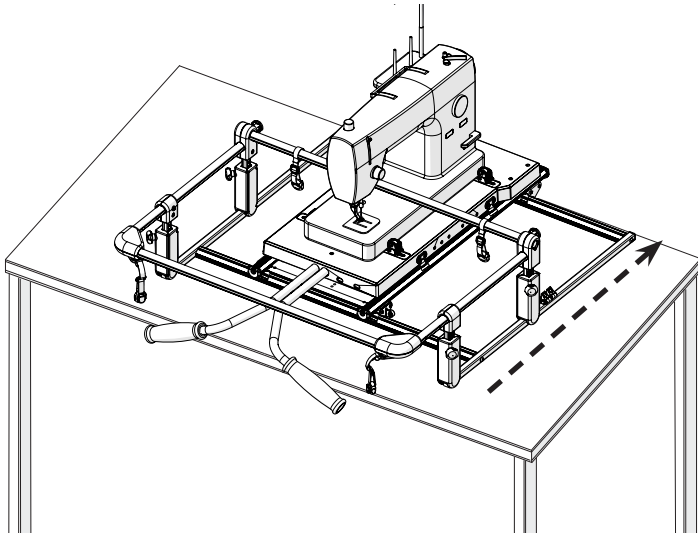

- 2 Unclamp the machine and line up the back of the machine with the back of the top plate. Reclamp the machine in its new position. See the note on page 13 for clarifications.

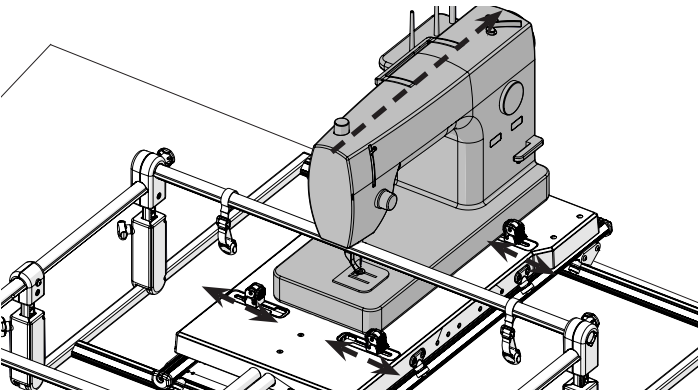

- 3 Route the **foot pedal cable** off the back of your machine and to the floor.

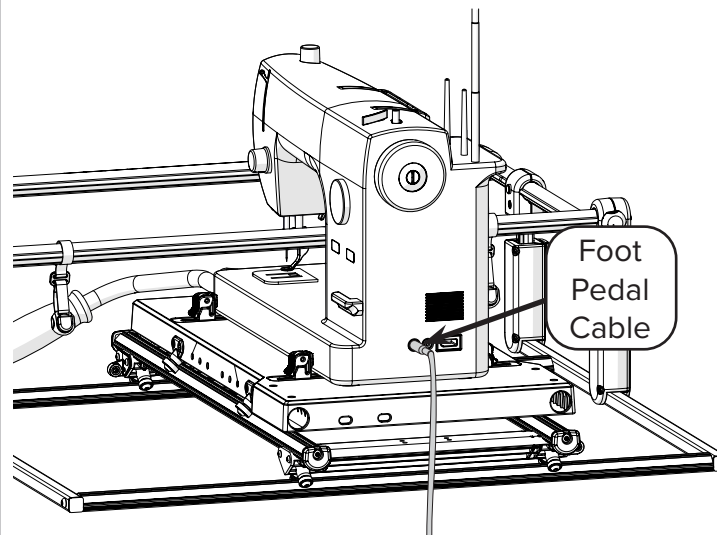

- 4 If you are dedicating this machine to quilting (not moving it off the frame regularly), then attach the **zip tie mount** to the top plate, and then **zip tie** the cable to the mount.

Note: If you have an extension cable, you can zip tie it to the top plate even if you are regularly taking the machine off the frame.

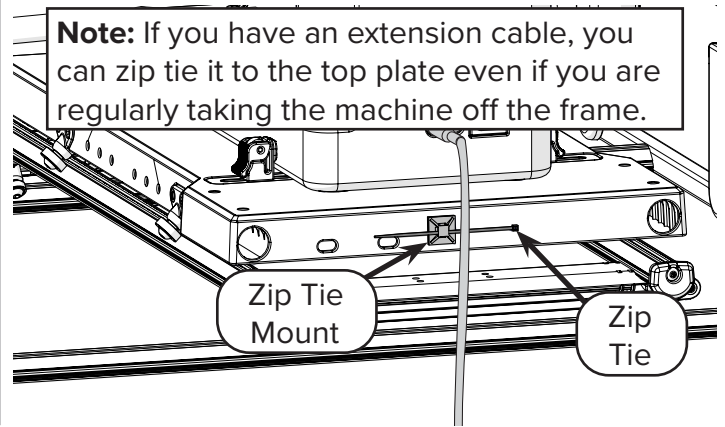

Route Cable from Front

- 1 Line up the front of the frame with the front edge of the table.

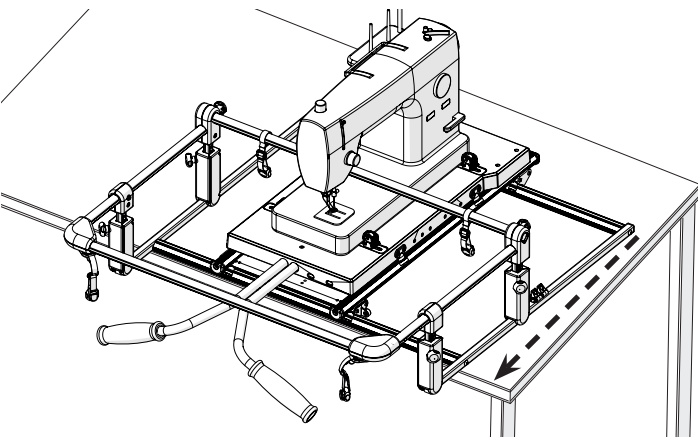

- 2 Unclamp the machine and line up the front of the machine with the front of the top plate. See the note on page 13 for clarifications.

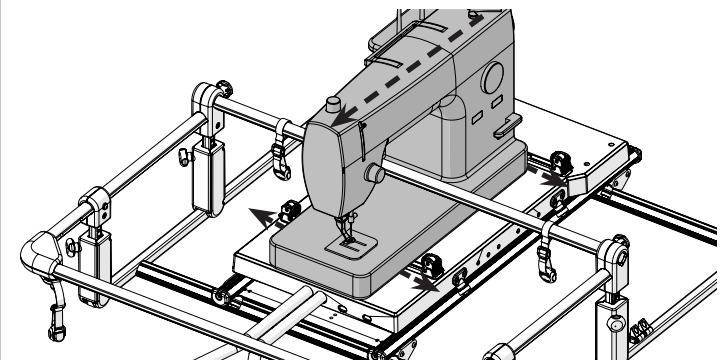

- 3 On the same side (left or right) as the **foot pedal cable port**, wrap the **foot pedal cable** around the machine, between the machine and the machine clamps.

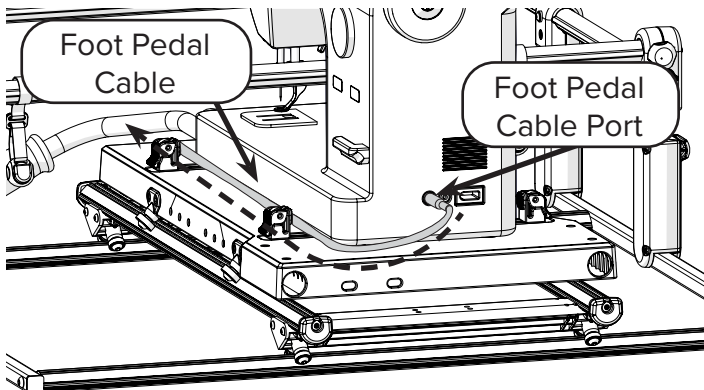

Note: Wrap the cable on the side closest to *your* foot pedal cable port, even if it doesn't match the example image.

- 4 Reclamp the machine in its new position.

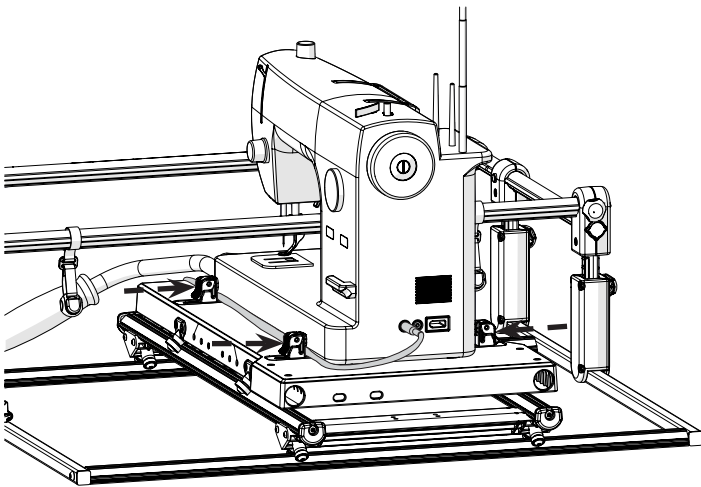

- 5 Route the foot pedal cable off the front of your machine and to the floor.

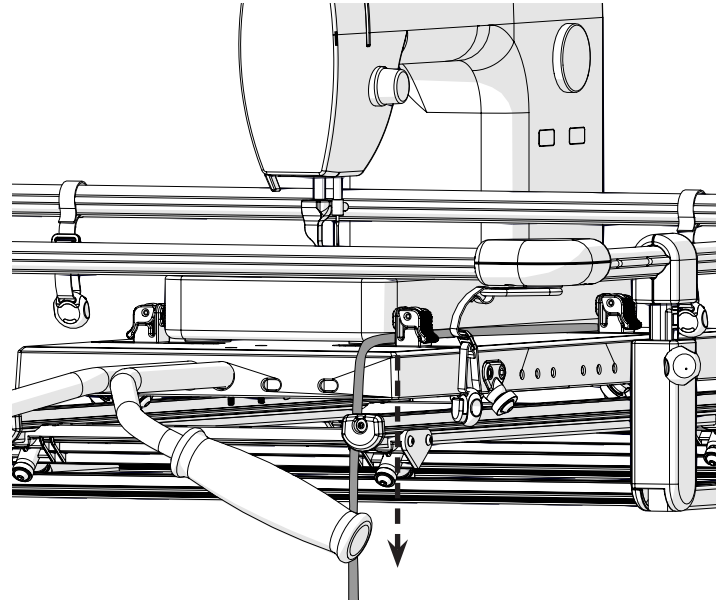

- 6 If you are dedicating this machine to quilting (not moving it off the frame regularly), then attach the **zip tie mount** to the top plate, and then **zip tie** the cable to the mount.

Note: If you have an extension cable, you can zip tie it to the top plate even if you are regularly taking the machine off the frame.

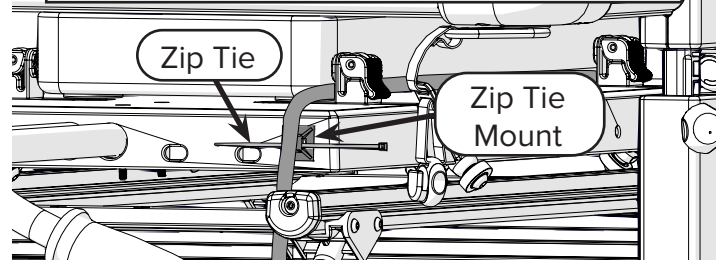

Task 10 - Preparing Your Sewing Machine for Quilting

Note: See your sewing machine manual for instructions on all of these steps.

To make sure that your sewing machine is set up for free-motion quilting:

- 1 If the option is available on your sewing machine, then switch to quilting mode.
- 2 Swap out your presser foot for a **free-motion or embroidery hopping foot**.

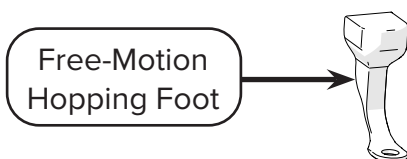

- 3 Lower your machine's feed dogs so they don't catch on the quilt backing, or install a feed-dog cover plate. **Note:** The switch to quilting mode might lower your feed dogs.
- 4 Perform all the normal tasks to set up your machine:
 - Plug in the machine.
 - Wind and install a bobbin.
 - Thread the machine.

Task 11 - Preparing Your Quilt Sandwich

Parts & Tools Needed: Fabric & Batting (not included); Pins (not included); Fabric Marking Pencil or Chalk (not included); Measuring Tape or Ruler (not included)

Note: The first time you prepare a quilt sandwich, use spare fabric and batting to practice.

To prepare your quilt sandwich:

- 1 Measure the length and width of your **quilt top**. Write down the measurements.

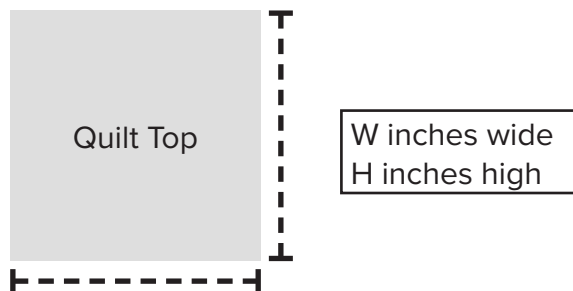

- 2 Cut **backing** and **batting** that is at least 16 inches wider and longer than your quilt top. (It's 8 inches bigger all the way around.)

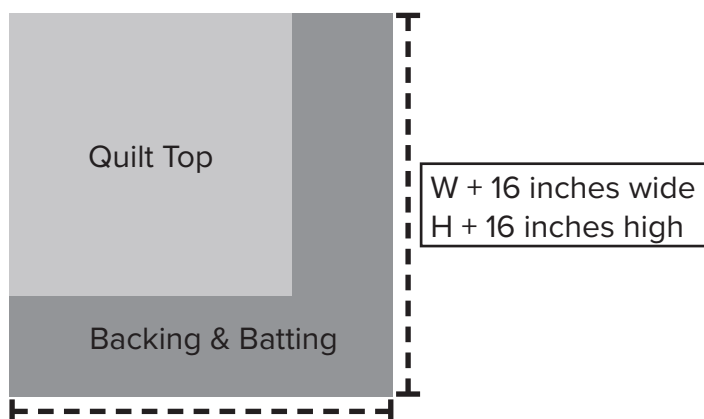

- 3 Fold your quilt top in half with the **right side** facing out. **Mark** the center of the top edge with a pin or marker on the right side.

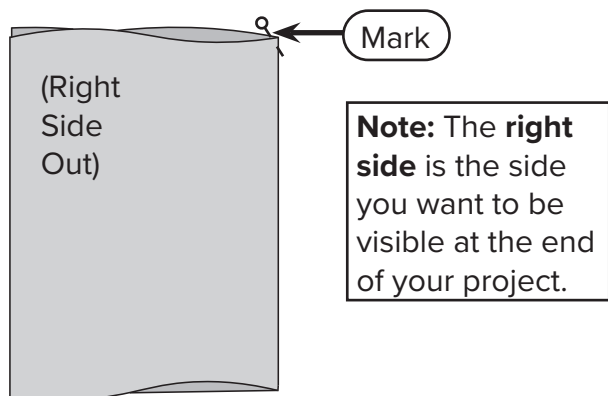

- 4 Fold the batting in half with the **scrim side** facing in. **Mark** the center of the top edge. Then use a ruler to make a **second mark 8"** below the first.

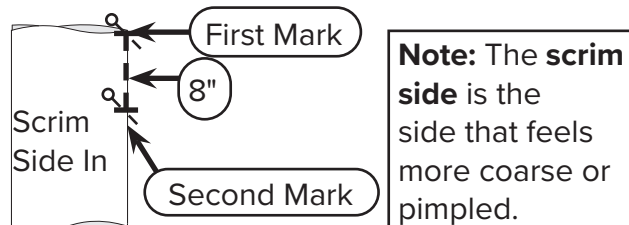

- 5 Align the mark on the quilt top with the second mark on the batting. **Pin** the two layers together, so the right side of the quilt top is facing up, and the scrim side of the batting is facing down.

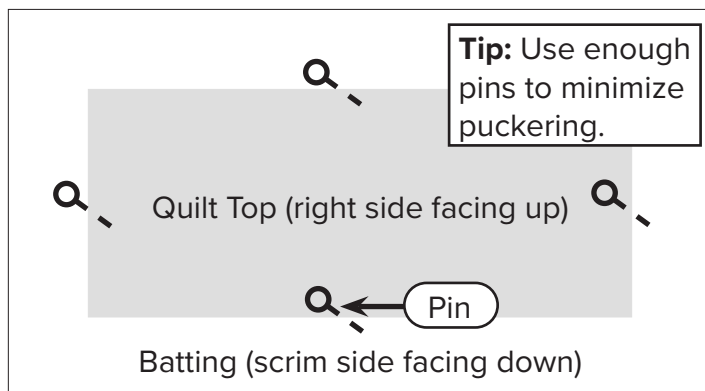

- 6 Lay your **backing** down, **wrong side** facing up. Make sure to smooth out any wrinkles in the fabric.

Note: The **wrong side** is the side you want to be hidden at the end of your project.

Backing (wrong side facing up)

- 7 Lay the batting and quilt top over the backing and **pin** the layers together.

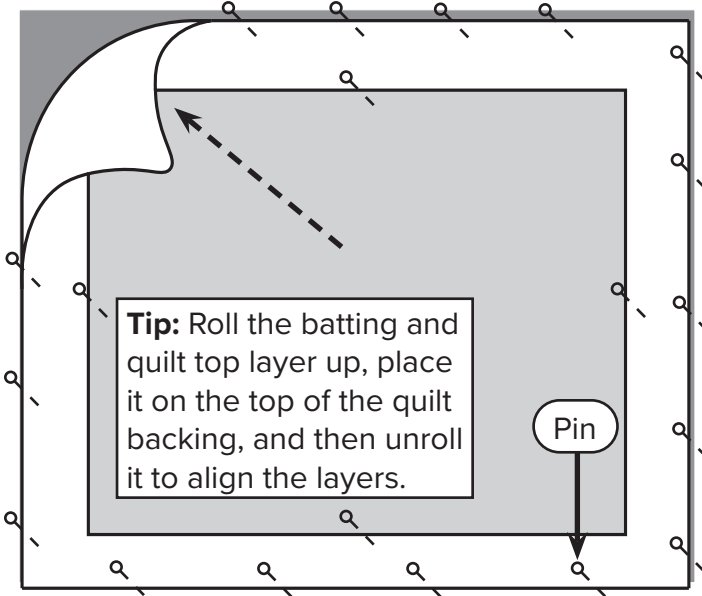

- 8 Roll the quilt up from the **bottom edge** so you can easily carry it to your frame.

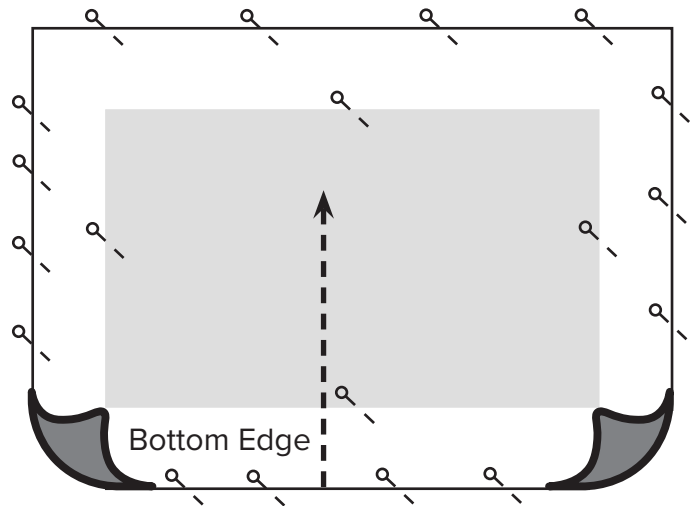

Task 12 - Attaching Your Quilt

Take the following steps to attach your quilt

- 1 Carry the rolled-up quilt to your frame. **Note:** As you place the fabric, keep the fabric wrinkle-free.

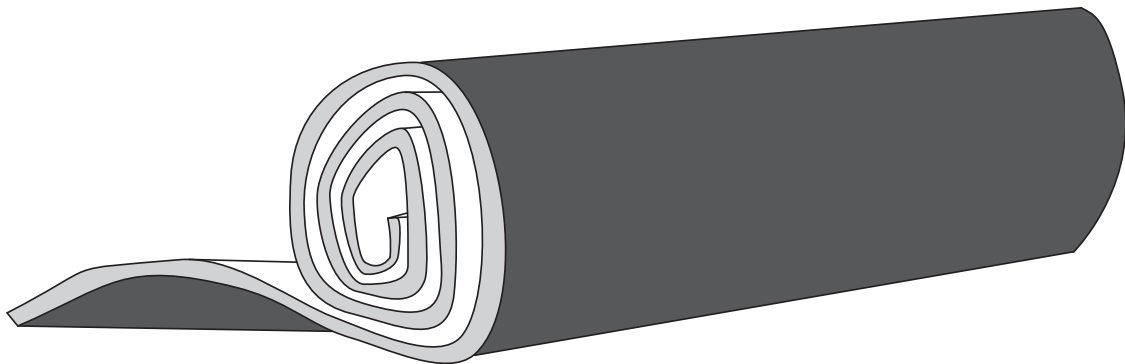

- 2 If needed, remove all the fabric clamps from the rails.

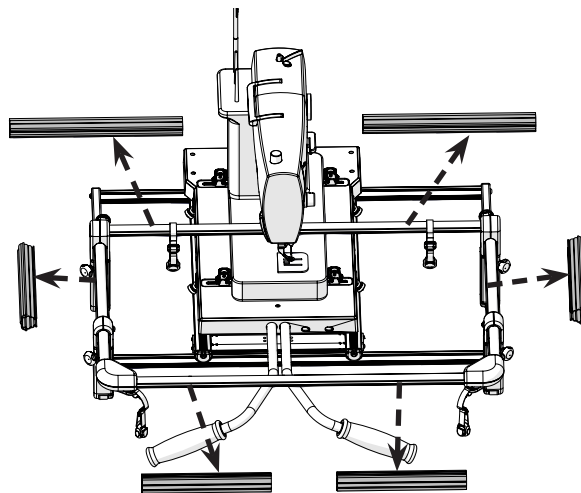

- 3 Raise the needle on your machine. Slide the top edge of the quilt under the hopping foot. Drape the quilt over the rest of the frame, doing your best to keep the quilt square with the frame.

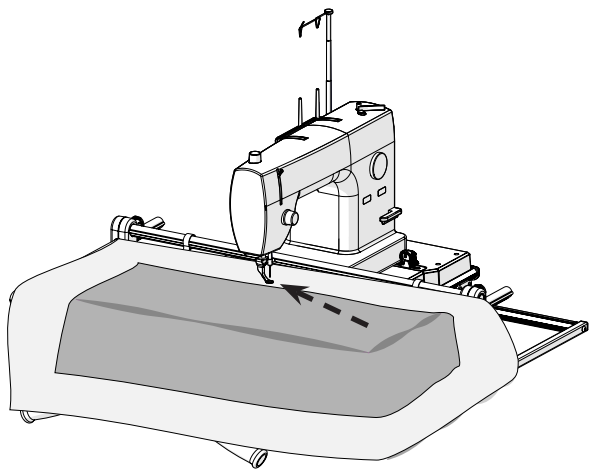

- 4 Align the **top-left corner** of your quilt top roughly near, but not touching, the top-left corner of your frame. **Tip:** Put one **clamp** on the take-up rail to keep the fabric from falling off.

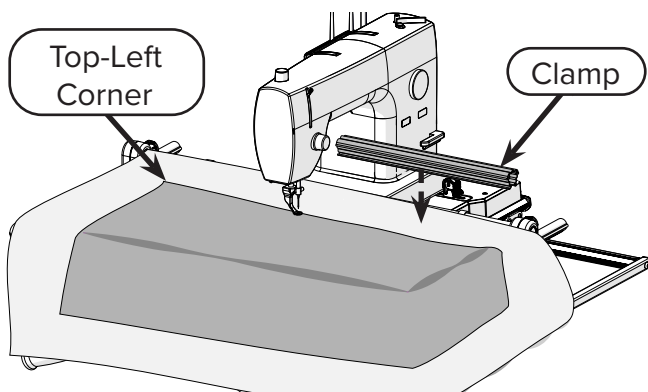

- 5 Do the following to place your quilt top:

- a On the **placement template**, find the long **line at 1 1/2 inches**. Draw a line across the template there.

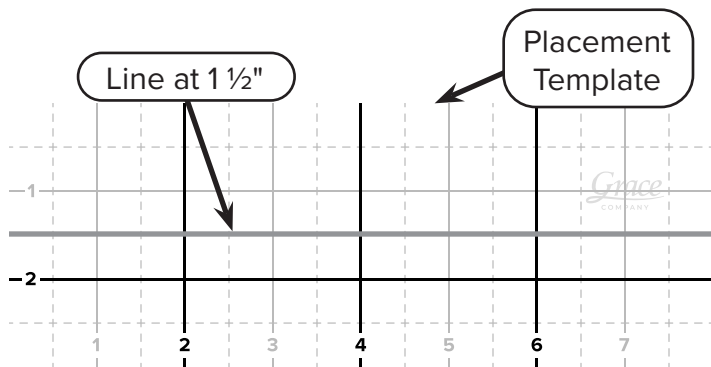

- b In the top-left corner of the frame, orient the template so that the short side is touching the left side rail and the long side is touching the take-up rail.

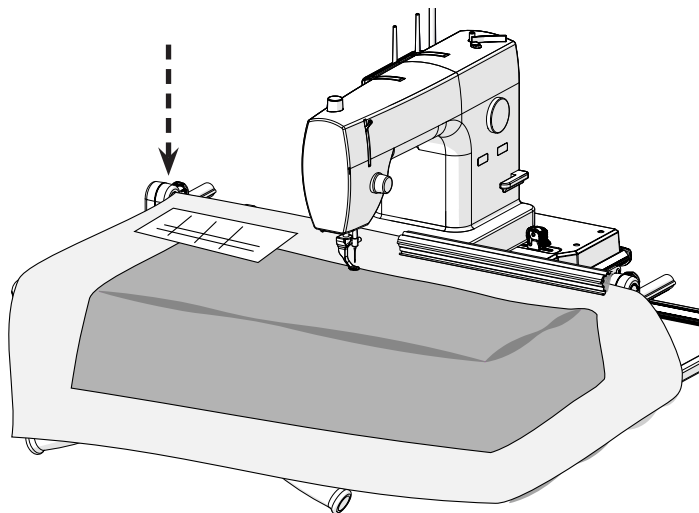

- c Adjust the quilt sandwich to place the top-left corner of the quilt top such that it aligns with the **1 1/2 inch** line and the right edge of the template.

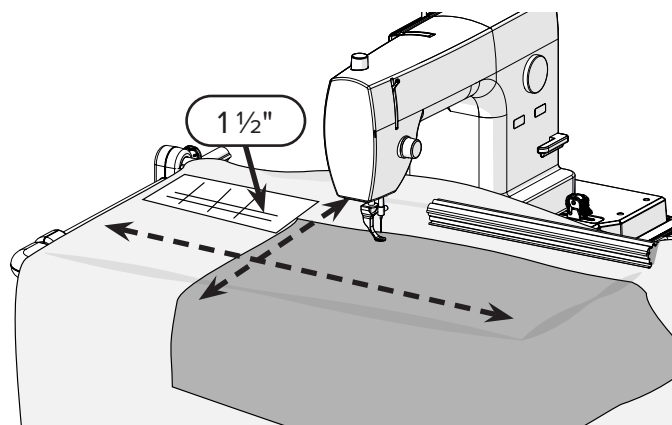

- d Slide the template along the top and left edges (one at a time). Adjust your quilt sandwich to make sure the quilt top is straight and square all the way across and down the frame.

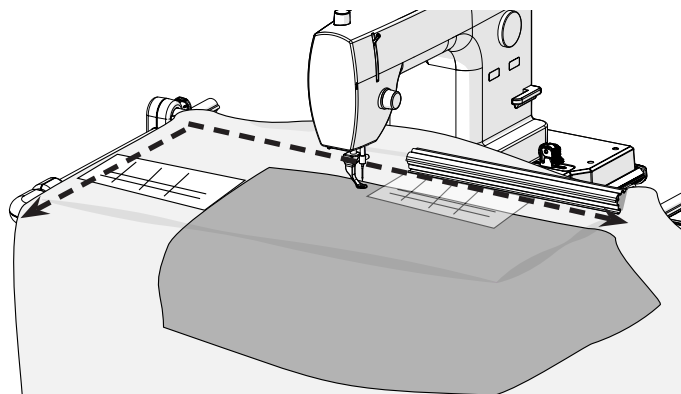

- 6 Once the quilt top is in the correct place, use the front/side and take-up clamps to hold the fabric. Make sure to use the correct clamp on the different rails. The front/side clamps are shorter and have a diamond symbol line, while the take-up clamps are longer and have the Mini-Quilter logo.

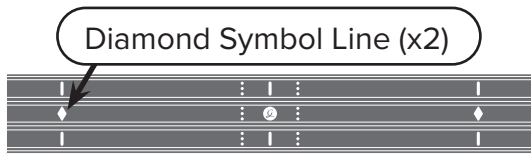

Diamond Symbol Line (x2)

Front/Side Clamp (x4)



Mini-Quilter Logo

Take-Up Clamp (x2)

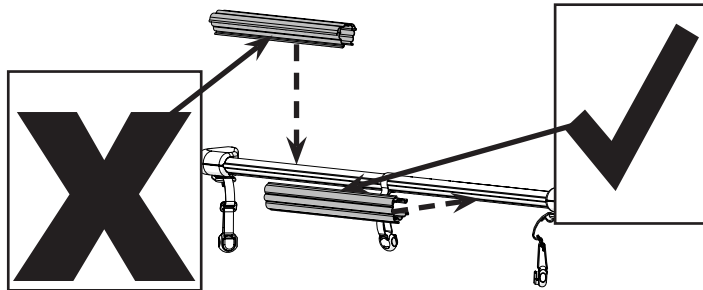

Tip: When you put the clamps on the front and side rails, insert them from the side, not the top.

Do the following to place the clamps:

- a On the left, press a take-up clamp onto the take-up rail so that the edge of the clamp is against the rail holder tower.

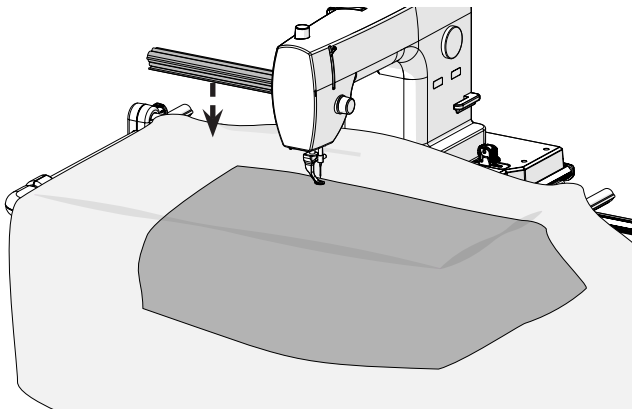

- b On the left side of the front rail, place a front/side clamp so that the edge of the clamp is against the corner of the rail.

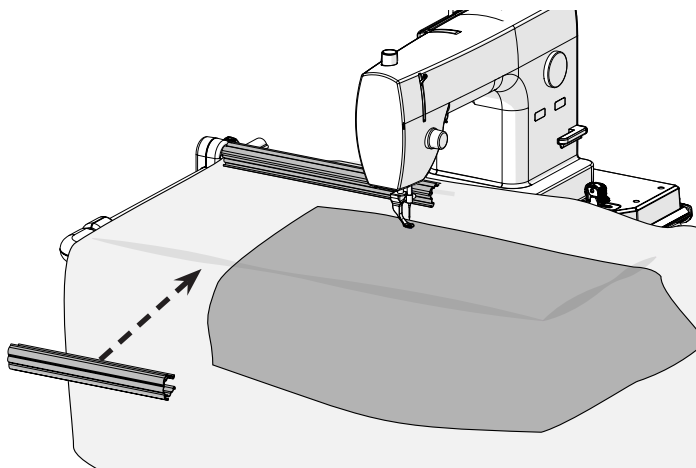

- c Repeat steps 6a-b on the right side of the frame.

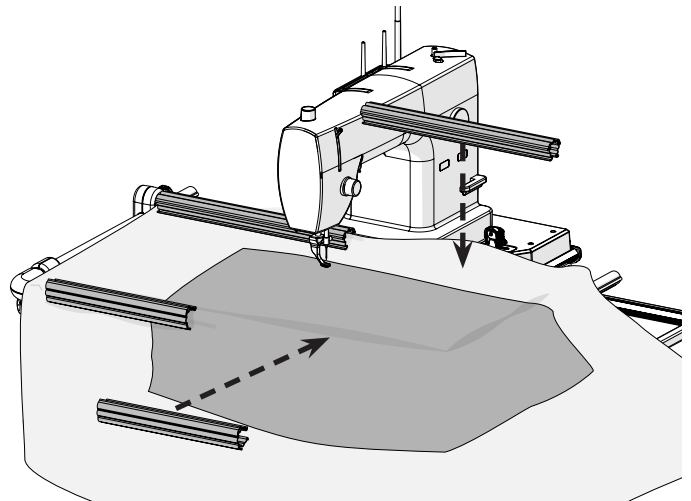

- d On each side of the frame, place a front/side clamp so that the edge closest to the take-up rail is touching the tower.

Note: While you're working at the edges of the quilt, you might not be able to clamp the fabric down on that side. Just place the clamp on the rail anyway, as it will help you mark your quiltable area. See page 19 for more details.

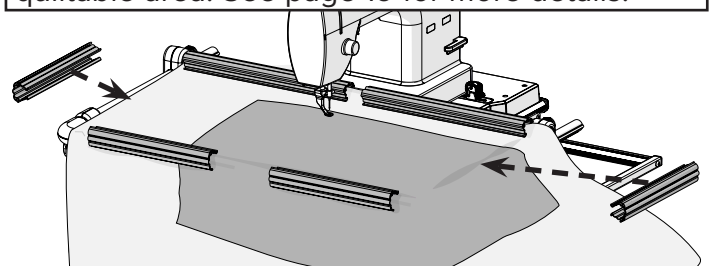

Task 13 - Testing Your Fabric Tension

Parts & Tools Needed: Penny (not included)

To test your fabric tension:

- 1 Drop a penny from about 6 inches from the surface of the fabric.

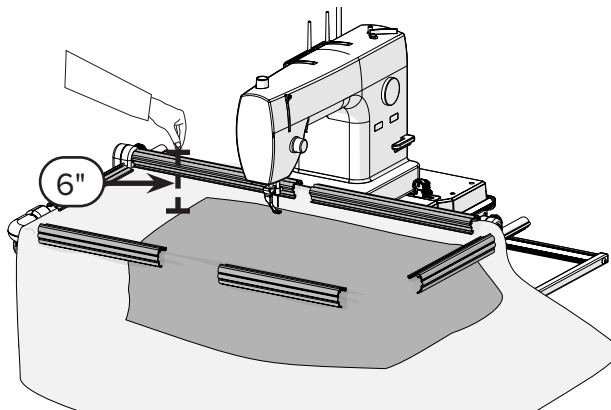

If the penny bounces and completely clears the fabric, then the tension is too tight. If the penny only partially bounces and doesn't fully lift from the fabric, then the tension is good. If the penny doesn't bounce at all, or seems to roll to a low spot in the fabric, then the tension is too loose. Most of the time, your fabric tension will either be too loose or good.

- 2 Do one of the following:
 - a If your tension is good, then continue to the next task.
 - b If your tension is too loose, then remove the fabric clamps from the front rail, and pull your quilt toward the front rail a little. Replace the fabric clamps, and then test your tension again.
 - c If, on the very rare occasion, your tension is too tight, then remove the fabric clamps from the front rail and shift your quilt sandwich toward the take-up rail, or away from the side rails a little. Replace the fabric clamps, and then test your tension again.

Task 14 - Marking Your Quiltable Area

Because of the length of your machine's throat and the way the frame is built, you can't quilt on every inch of the frame's hoop. The space you can quilt on is the *quiltable area*.

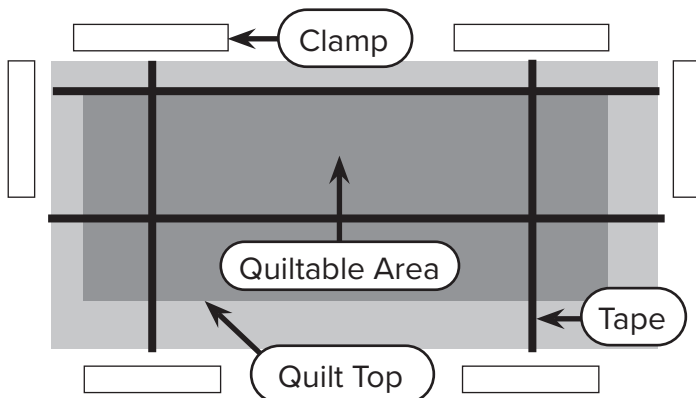

Learn the **quiltable area** of your frame to keep your frame, machine, and, most importantly, your **quilt top** safe. Staying in the quiltable area makes sure you don't hit the carriage on the side of the frame. If you do hit something, you can bump the needle and disrupt the plan for your designs. While you're learning the quiltable area, use **tape** to visualize it. After you're comfortable with the space, you can use the lines on the **clamps** as the only indicators.

To mark your quiltable area:

- 1 Look at the fabric clamps. They have symbols on them to indicate the edges of your quiltable area. The **diamond lines** indicate the horizontal edge near the take-up rail, while the **G-logo lines** indicate the vertical edges. The **dotted lines** are for you to use if the offset of your needle is such that the G-logo line doesn't work for your machine. **Note:** The horizontal edge of the quiltable area near the front rail is very dependent on the length of your machine, so none of the clamps can help with indicating that edge. This task will help you understand how to indicate that edge for yourself. **Tip:** While marking the edges, put the tape on the outside edge of the lines.

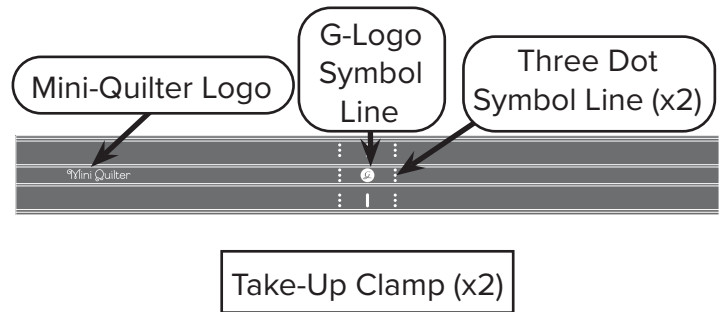
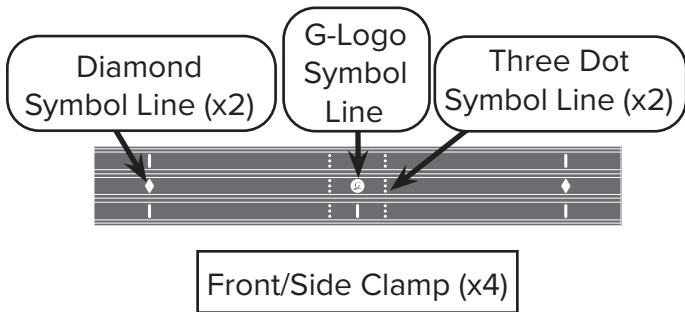

- 2 Move your machine toward the middle of the frame near the front rail. Stop when one of two things happens: the back of the **throat** is about 1 inch from the take-up rail OR your **needle** is about 1 ½ inches away from the front rail.

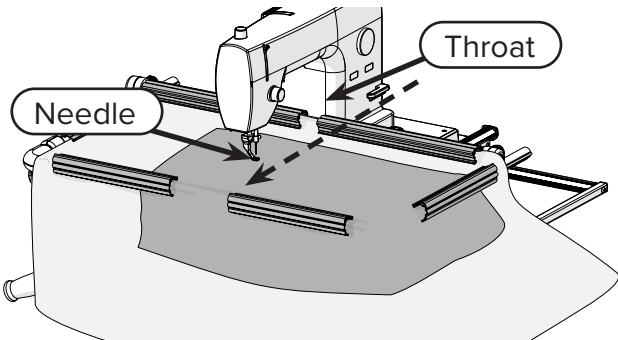

- 3 At your needle, use a piece of **tape** to mark a line all the way across the frame. This is one edge of your quiltable area. **Tip:** Slide the placement template along the line to confirm that it's straight.

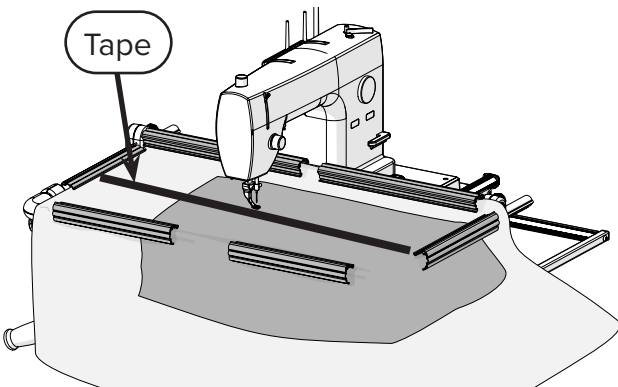

- 4 Use a piece of tape to mark a **line** between the diamond lines on the side clamps that are near the take-up rail. This is another edge of your quiltable area.

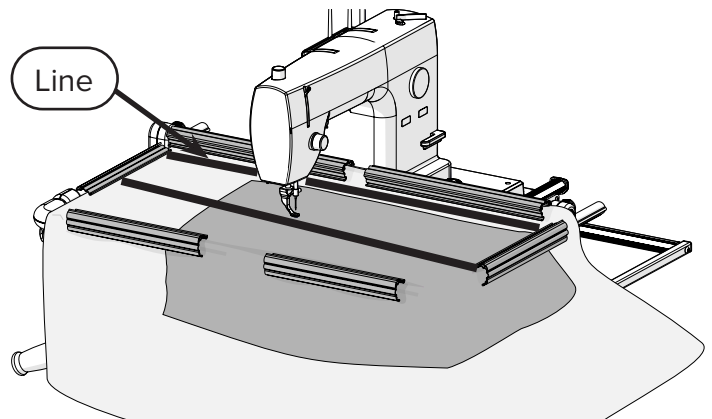

- 5 Use piece of tape to mark a **line** between the G-logo lines on the left clamps on the take-up and front rails.

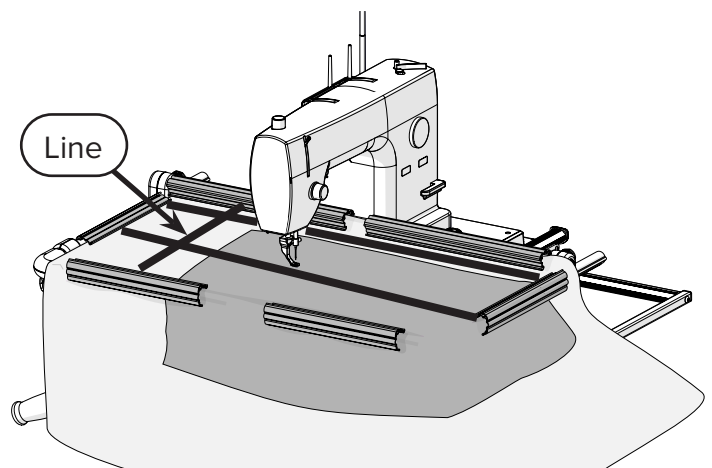

- Use a piece of tape to mark a line between the G-logo lines on the right clamps on the take-up and front rails.

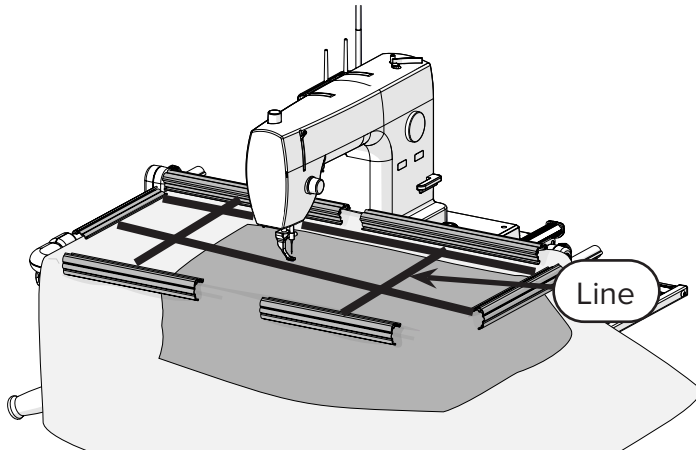

- These four lines mark the outside edge of your quiltable area. While quilting, *don't* move the needle outside of these lines. Remember, staying in the quiltable area makes sure you don't hit the carriage on the side of the frame. If you do hit something, you can bump the needle and disrupt the plan for your designs.

Note: As you gain confidence with your frame, you might decide that you don't need lines of tape and can just use the marks on the clamps to visualize the quiltable area. But if you have *any* doubts, take the time to fully visualize where you can safely quilt.

Task 15 - Using the Elastic Clips

If your fabric is draping over the front or back of the frame (potentially getting in the way of you moving the machine around), use the elastic clips to hold the fabric up and out of the way.

To use the elastic clips:

- Roll up any fabric that is draping over the frame. Loop the **elastic clip's** band around the fabric and over the clamp. Slide the **hook** of the clip into the **ridge on the clamp**.

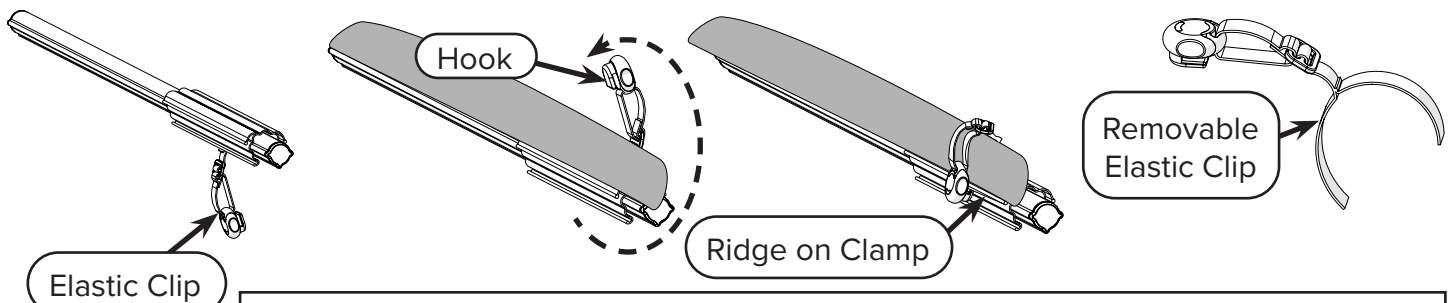

Tip: If your project is small, add the **removable elastic clip** to the front rail. Undo the velcro, wrap it around the middle of the front rail, and then use it like the others.

Task 16 - Starting & Ending Your Designs

Parts & Tools Needed: Scissors (not included)

If the bobbin thread is under your quilt sandwich as you stitch your designs, it can get tangled or sewn into the quilt. To prevent this, start and end your designs by making sure the bobbin tail is on top of the quilt sandwich.

To start and end your designs:

- Before you start stitching, pull up your bobbin thread to prevent the thread tail from dangling underneath the fabric and getting sewn in place as you quilt.

Take the following steps to pull up your bobbing at the start of stitching:

- Position the needle where you want to begin stitching (for example, the top-left corner of your quiltable area, or the edge of the quilt top when you are tacking down your edges).

- b Pick up and hold the **top thread tail** so that it is taut. **Note:** It doesn't matter whether the thread is under the hopping foot or not.

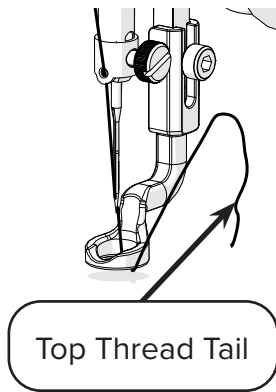

- c While still holding the top thread tail, make a **single stitch**. (Use whatever method your machine provides.)

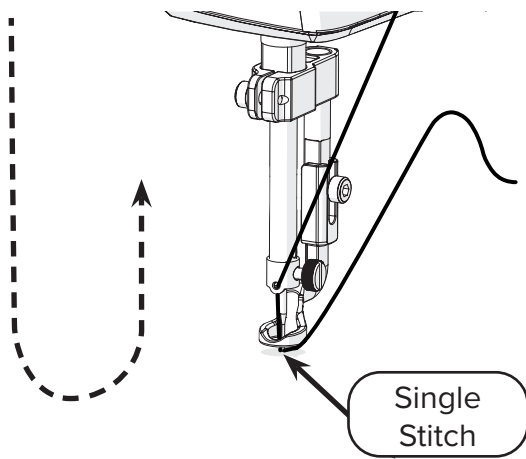

- d Continue holding the top thread tail, and move the machine several inches to the side. The top thread pulls a **loop** of bobbin thread through the **start point** in the top of the fabric.

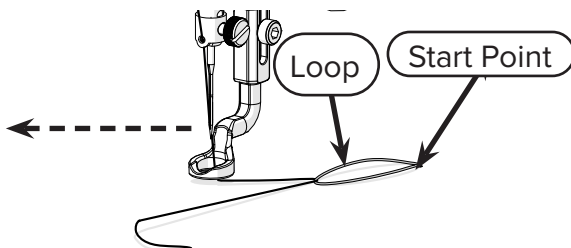

- e Continue pulling until the loose end of the **bobbin tail** comes up from underneath the fabric.

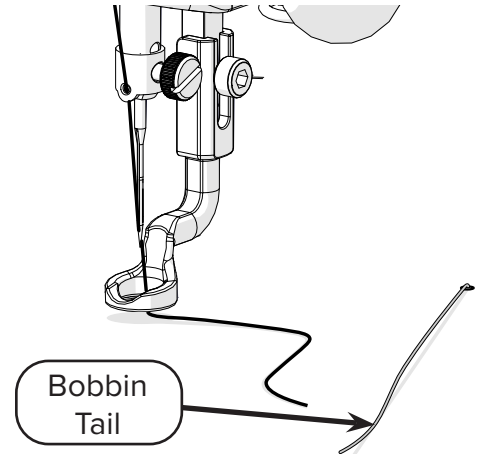

- f Gather up both **thread tails** and move the machine back to the **start point**. Pull on the thread tails, especially the bobbin tail, until both threads are tight.

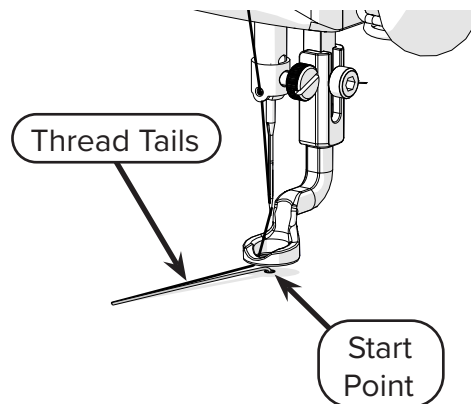

- 2 Secure your design by making three **securing stitches** very close together right next to the place where you pulled up the bobbin thread. **Note:** You don't have to do the securing stitches when you are tacking down your edges.

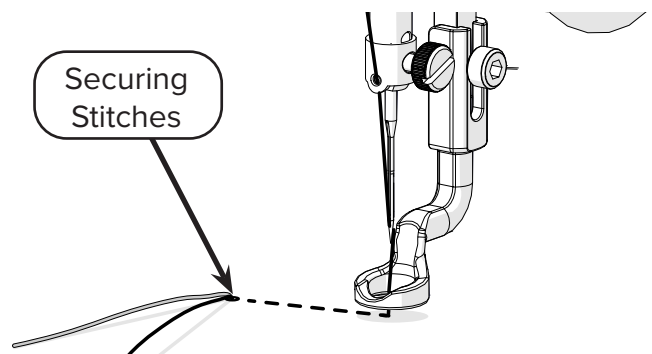

- 3 Stitch your **designs**. Remember to take the time to practice with scrap fabric before quilting on your projects. Quilting with a machine on a frame is a skill, and a new skill takes time and practice to master.

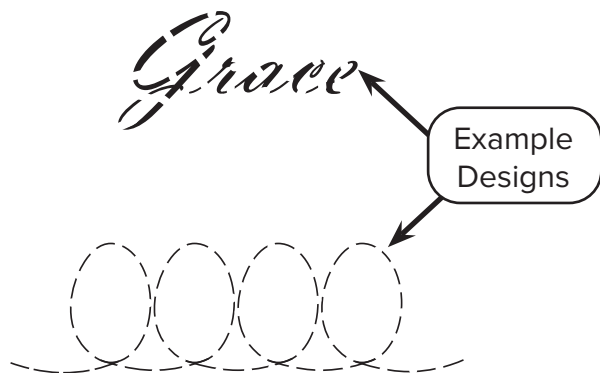

- 4 Once you are finished stitching, complete your design by making three **securing stitches** very close together at the end of your design. **Note:** You don't have to do the securing stitches when you are tacking down your edges.

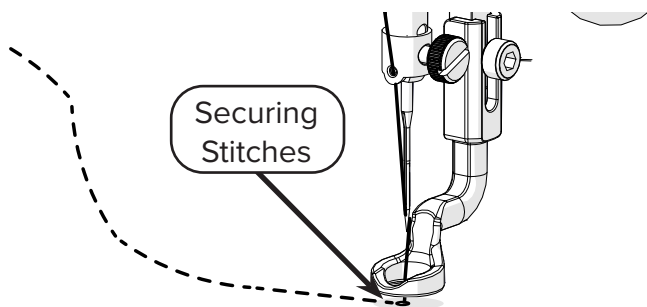

- 5 Pull up your bobbin thread to prevent the thread tails from dangling underneath the fabric and getting sewn in place as you quilt.

Take the following steps to pull up your bobbin thread at the end of stitching:

- a Move the machine away from the last stitch.

Note: The process of pulling up the bobbin thread at the end of stitching is slightly different from the start of stitching.

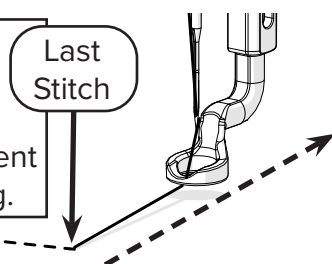

- b Hold the **top thread** to make a **loop**, and then return the needle to the last stitch.

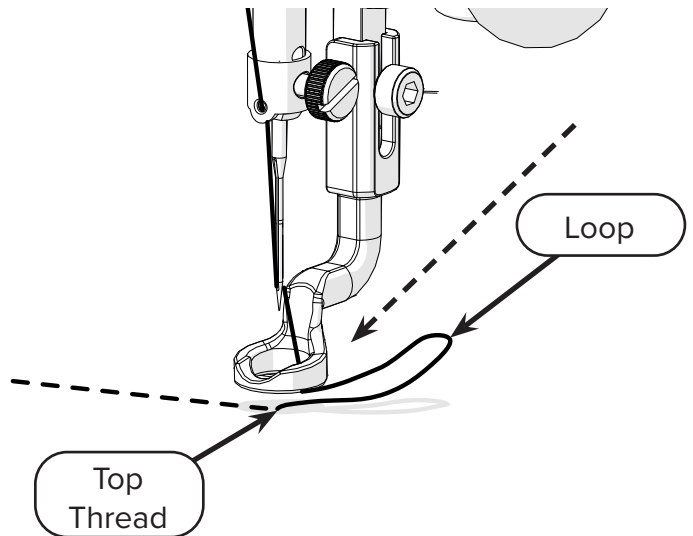

- c While still holding the loop, make a single stitch over the last securing stitch.

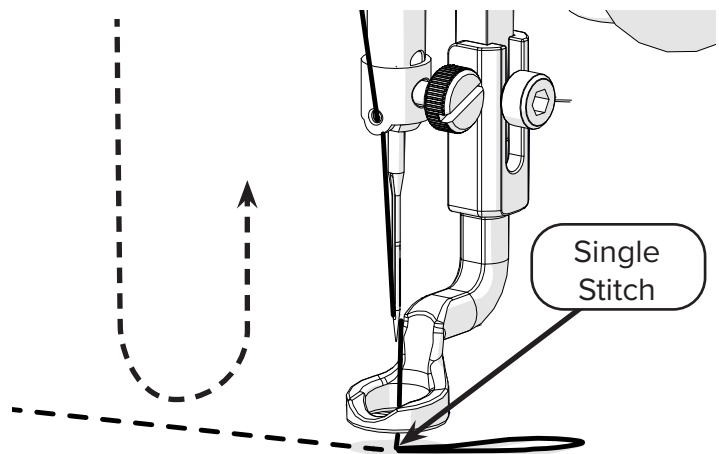

- d Continue to hold the loop and move the machine away from the last stitch again.

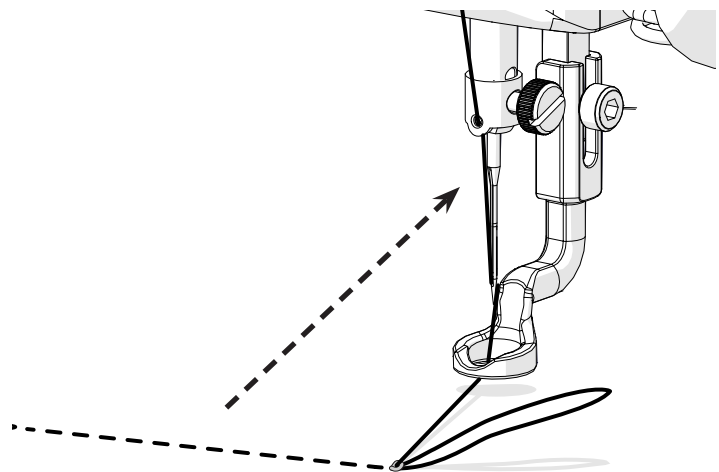

- e As you move away from the last stitch, a **loop of bobbin thread** is pulled up. Keep moving away until the loop is big enough to grab.

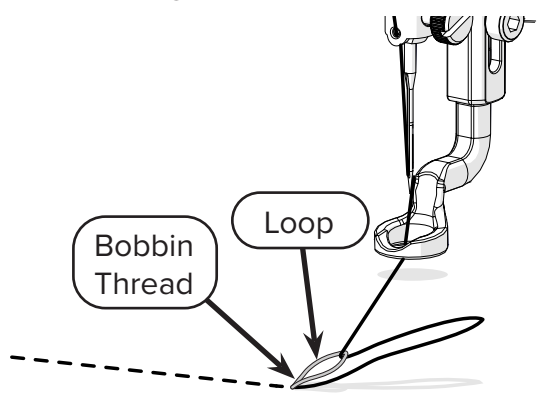

- f Cut all the threads close to the securing stitches at the end of the design. Also cut the thread tails from the beginning of your design.

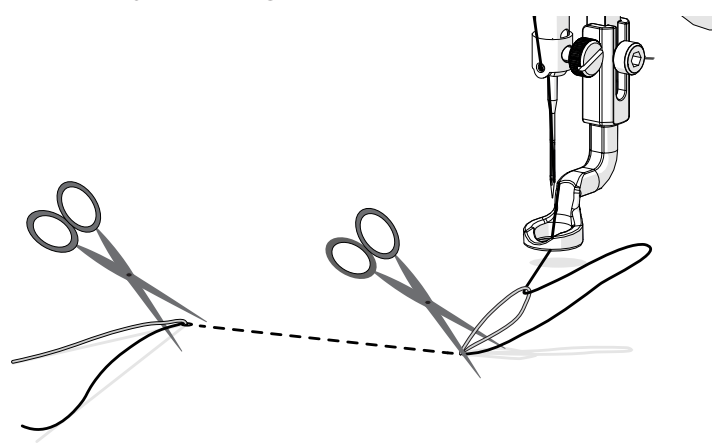

Task 17 - Tacking Down the Quilt Top Edges

To tack down your quilt top edges and help keep your quilt top from shrinking as you fill it in:

- 1 Starting in the front-left corner of the quilt top, stitch along the edges of the quilt top, about ¼ inch from the backing and batting.

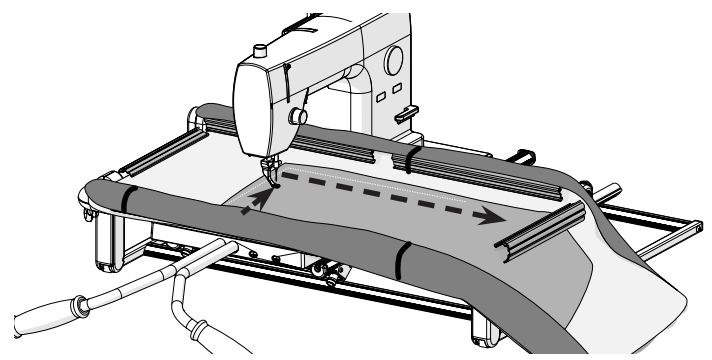

Note: Every time you shift your quilt to sew a new area, tack down the revealed edges.

Task 18 - Moving Your Quilt to a Different Zone

Many quilts are larger than your hoop's quiltable area. Therefore, you must create zones on the quilt that you fully quilt before you move the quilt to a different section. The following image is an example of how you might set up the zones on your quilt.

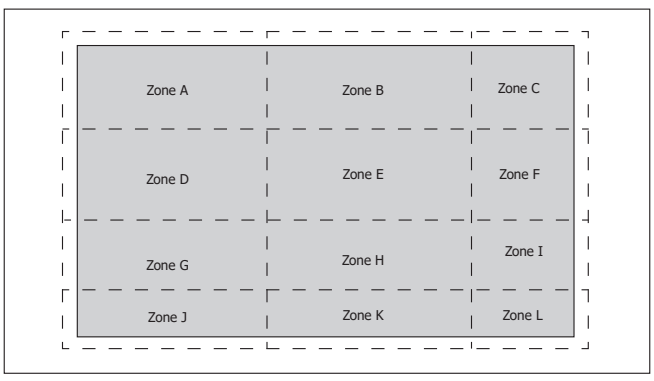

Your quilt might have more or fewer zones depending on the size and shape of the quilt. In general, the best method is to start at the top-left corner of your quilt, stitch each zone across, and then move down to the next row of zones.

To move your quilt to a different zone:

- 1 If you used the elastic clips to hold a roll of fabric on the rails, then unhook the clips and allow the fabric to hang freely.

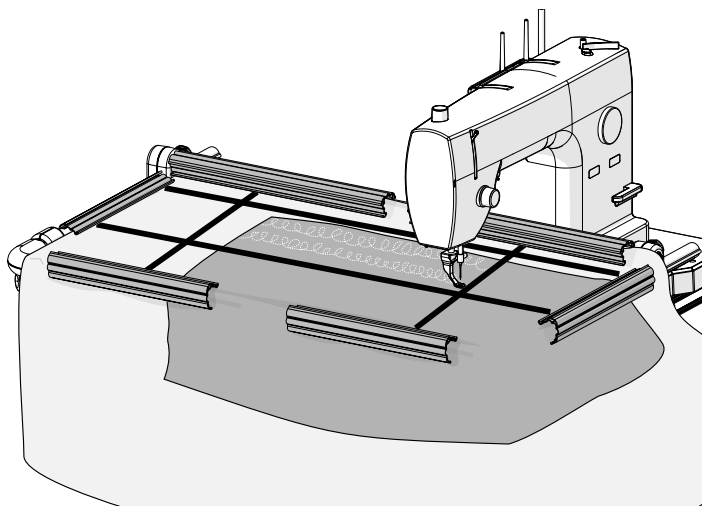

- 2 Leave one clamp on the front rail on the side that is opposite of the direction you are moving your fabric. (For example, if you're moving the quilt to the left, keep the clamp on the right on the front rail.) Take the rest of the clamps off the frame.

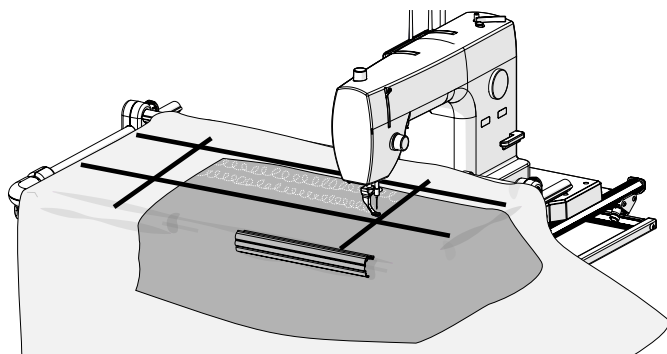

- 3 Use the clamp you left on the frame to slide your quilt so that the next zone of unstitched space is in the quiltable area.

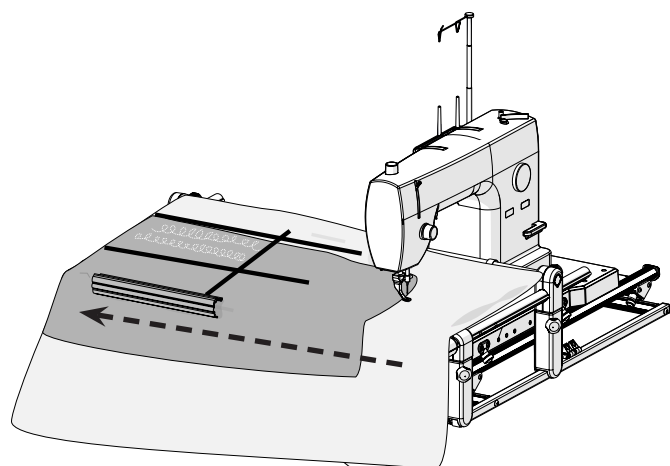

Note: To make sure your stitch lines are smooth and to avoid gaps in your designs, create about 2 inches of overlap between your zones, so that when you move to a different zone, 2 inches of the stitched area from the previous zone are in the quiltable area of the next zone. Once you're confident you have the overlap, take the tape marking your old quiltable area off the frame.

- 4 Replace the fabric clamps to secure the quilt in the new position. Remember to place the clamps so that they help you visualize your quiltable area.

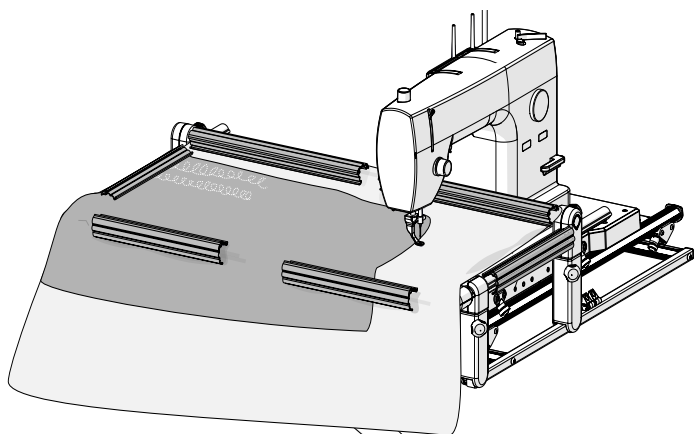

- 5 Roll up any draping fabric (on the front or the back). Tack down any revealed edges. Also, mark your quiltable area with tape.

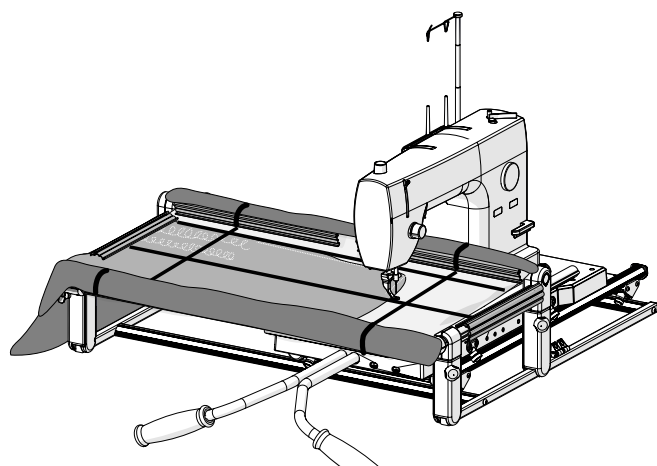

Task 19 - Using Additional Resources

The following pages in this booklet contain additional resources to help your quilting endeavors. Feel free to copy and reuse these resources as works best for you.

Design Tracing Paper

This sheet shows several basic designs you might want to stitch into your quilts. The lines on the arrows on the left side are hints of how to draw the designs in one continuous line. Copy these lines onto the practice grid or right onto your quilt if you want. Copy the paper to practice again.

Letter-Paper Sized Practice Grid

This sheet is for creating a practice grid using multiple pieces of 8 ½" x 11" paper. If you want to make a practice grid the same size as the one that came with your frame, copy the grid four times.

Cut off the top and left margins of each copy and then tape them together. Align the left edge of one copy with the right edge of another copy to increase the width of the grid, or align the top edge of one copy with the bottom edge of another copy to increase the length of the grid.

Placement Template

This sheet shows the placement template. You can copy it and cut or draw on it as much as you want. Although the original placement template that came with your frame is made of posterboard, you can copy your replacements onto normal paper. Normal paper works just fine for placing the quilt top.

Also, you can access printable copies of these resources as well as more digital resources for your Mini-Quilter frame by scanning the QR code with your phone's camera or by visiting <https://digitalcontent.graceframe.com/course/582/784>.



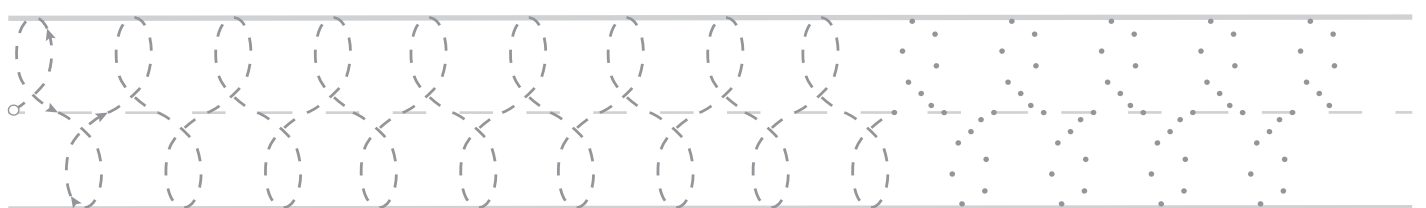
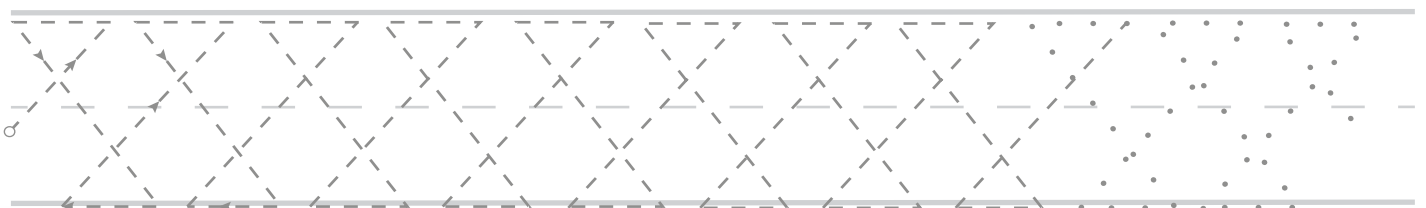
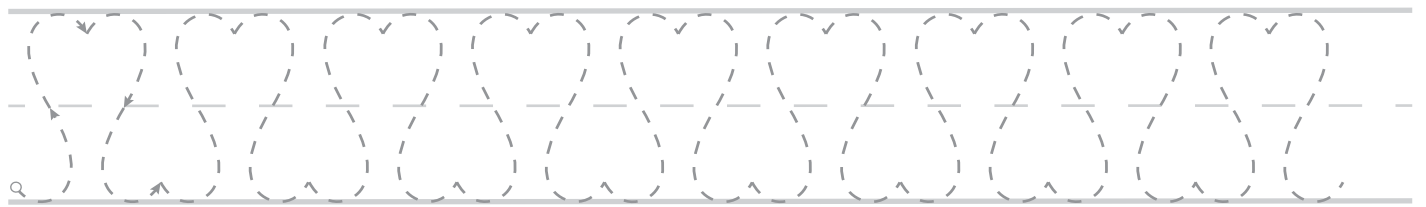
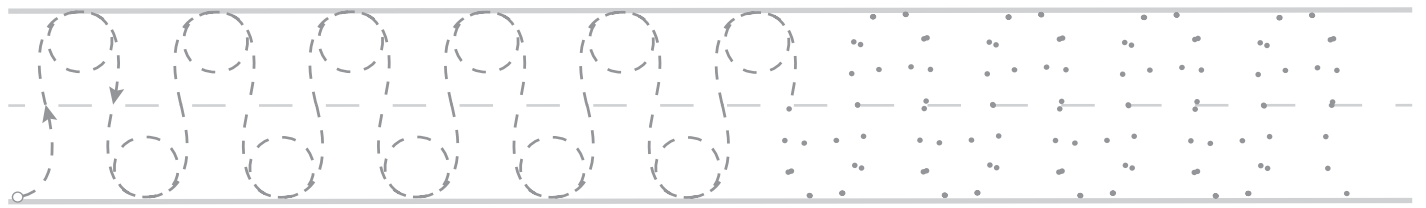
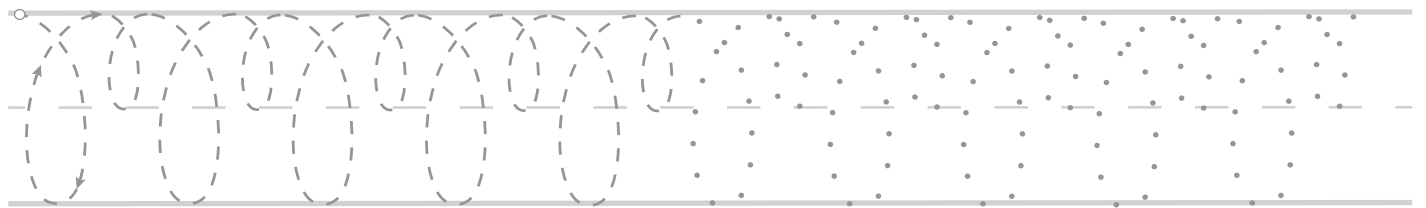
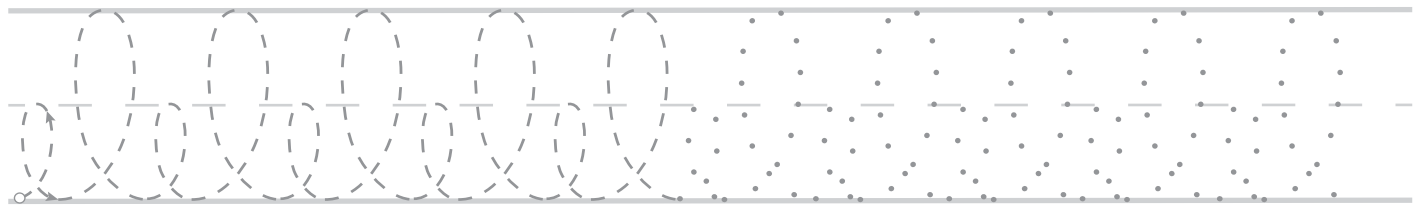
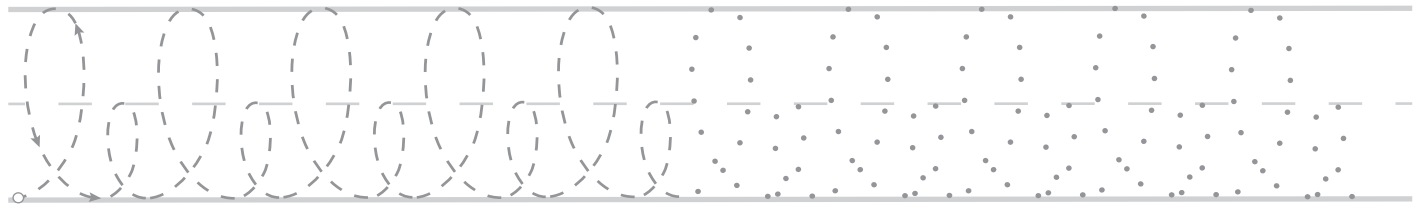

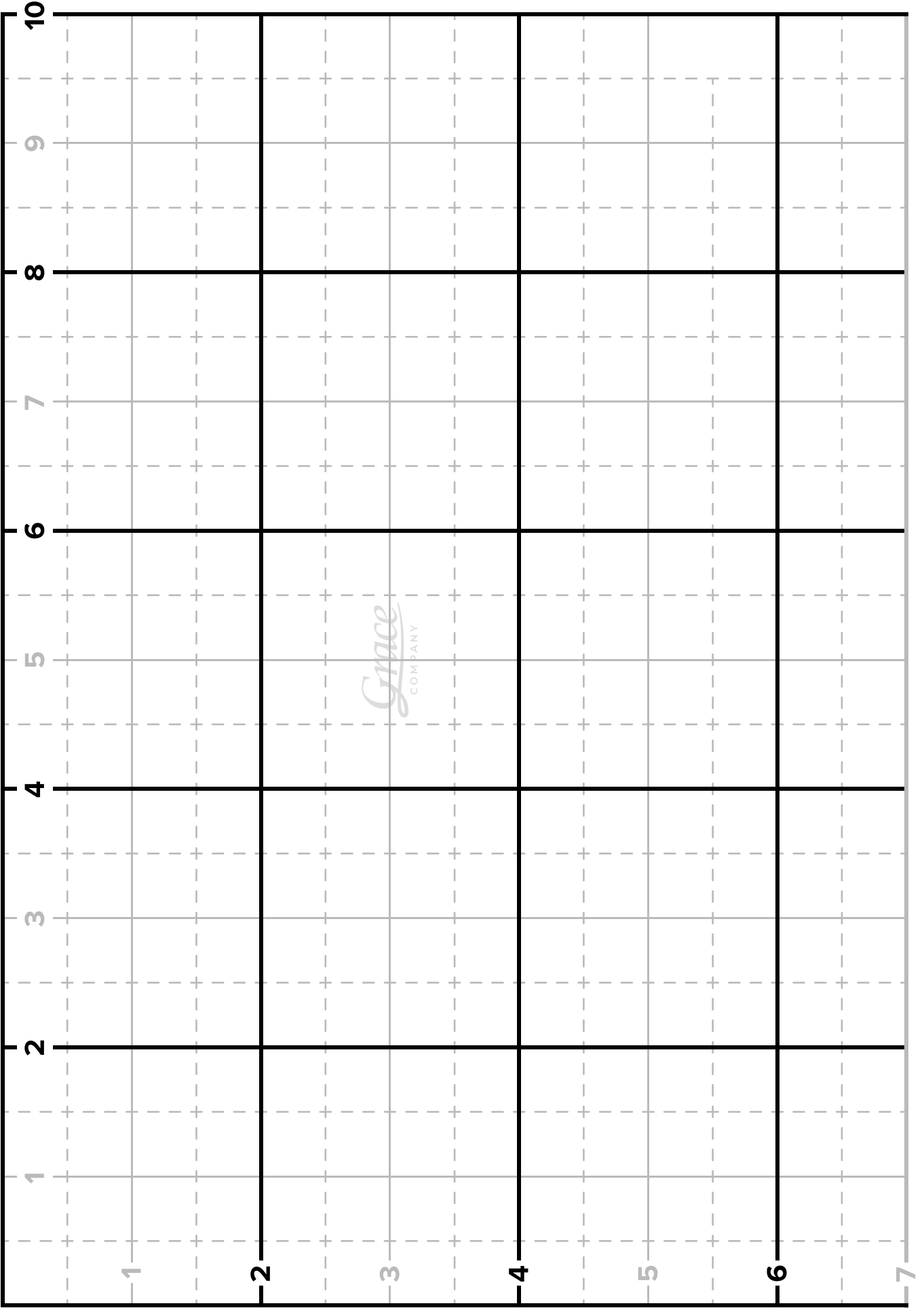

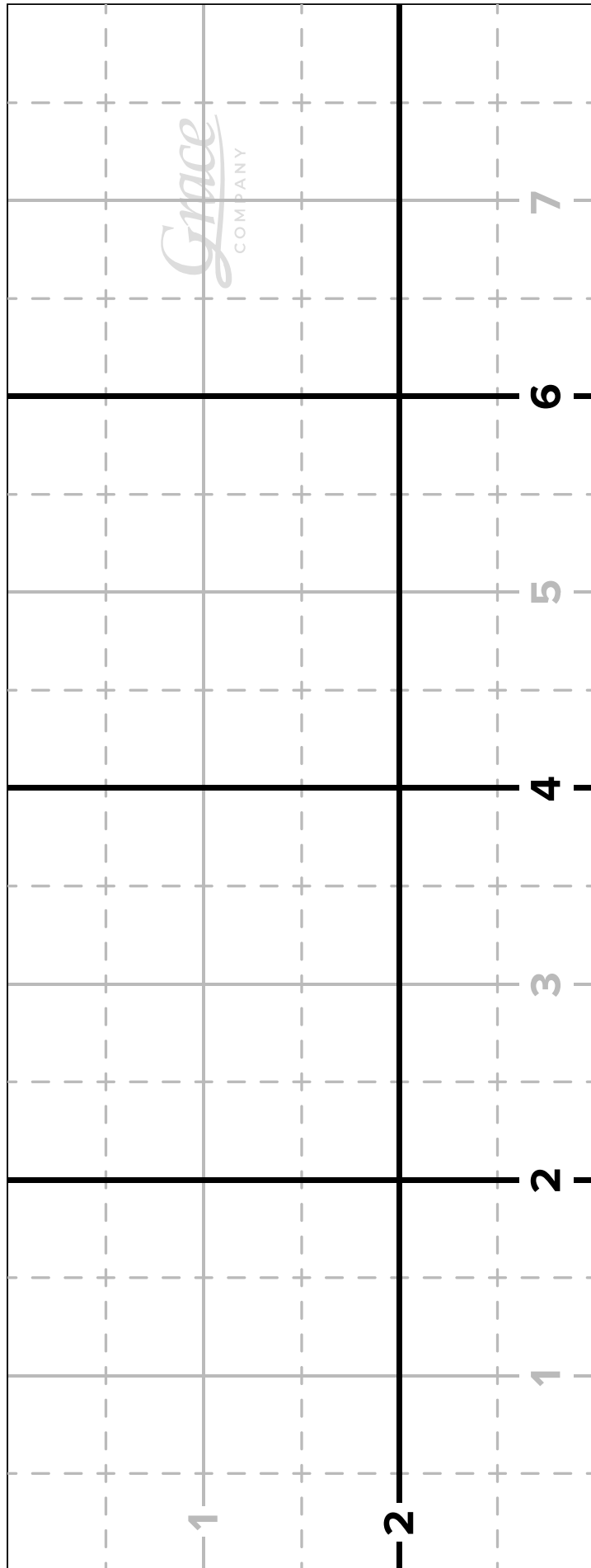

Notes

Use this space to take notes about your frame or your projects.

Notes

Use this space to take notes about your frame or your projects.

Grace
COMPANY

www.graceframe.com

1-801-485-6688