



Q'nique21 Hopping Foot Collar Instructions

Use:

The Hopping Foot Collar can be used to quickly swap between a variety of foot accessories for your machine.

Parts List:

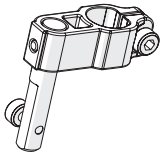

Hopping Foot Collar SM21
SMP-09-14524



SHCS
M3 x 8 mm
HDW-03-10966
(Preinstalled)

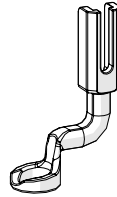

Standard Hopping Foot
SMP-04-10057

Installation Instructions:

- 1 Use a 3 mm Allen wrench to remove the **screw** attaching the hopping foot to the **hopping foot collar** on your machine.

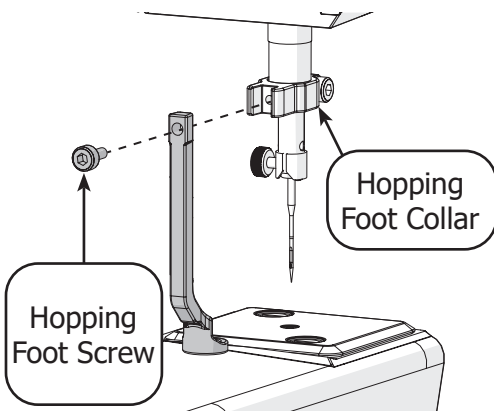

- 2 Remove the **needle bar thumb screw** and carefully pull out the needle.

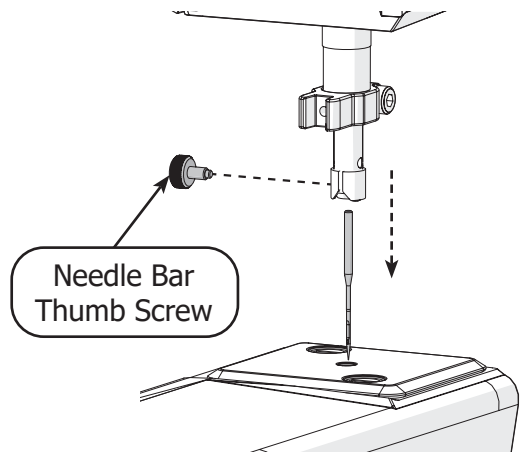

Installation Instructions Continued:

- 3 Use a 3 mm Allen wrench to loosen, but not remove, the collar screw. Slide the collar off the **press bar**.

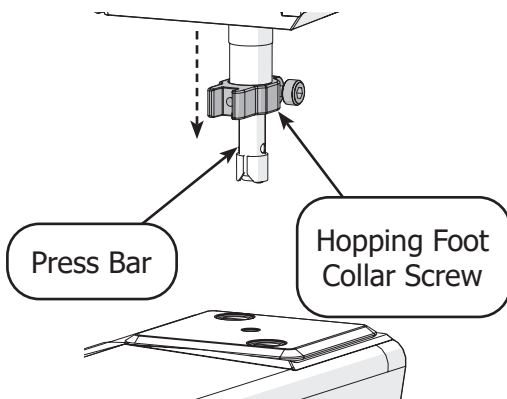

- 4 Attach the **new hopping foot collar** so that the bottom of the collar is even with the bottom of the press bar. Tighten the collar screw with the 3 mm Allen wrench.

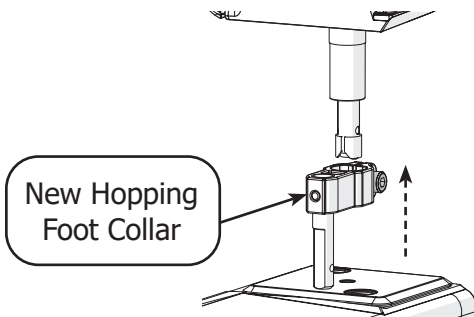

- 5 Place the **new standard hopping foot** onto the hopping foot collar bar. Loosely attach with the **M3 x 8 mm SHCS**.

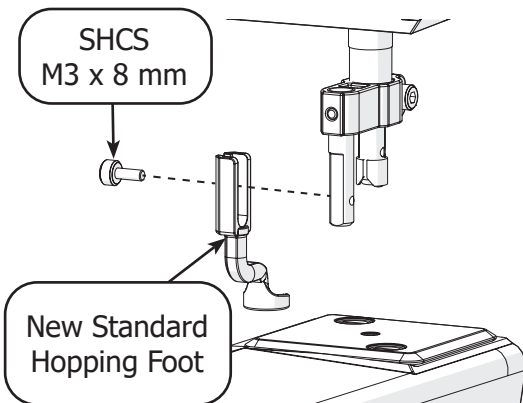

- 6 Reinstall your machine's needle and needle thumb screw (see your machine manual for details).

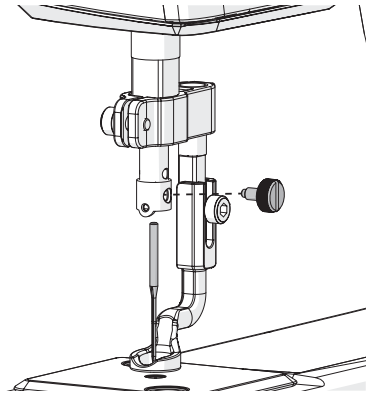

- 7 Carefully lower the needle to the lowest position.

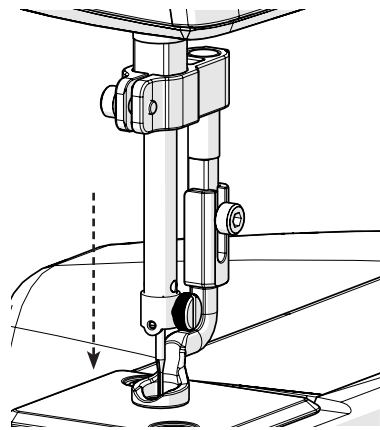

- 8 Slide the **hopping foot height tool** under the hopping foot, fitting the groove around the needle. Lower the foot until it rests on the height tool and tighten the hopping foot screw with a 3 mm Allen wrench.

