

# Troubleshooting Tension for Quilters

---

A Guide for Understanding and Solving Thread Tension Issues



*Grace*  
COMPANY



## TABLE OF CONTENTS

---

Introduction to Sewing Tension .....	1
What Influences Tension? .....	2
Tension Strategy .....	3
Tension Troubleshooting .....	4
Resetting the Check Spring .....	9
Bobbin Case Troubleshooting .....	10
Bobbin Wind Troubleshooting .....	13
Troubleshooting Breaking Thread .....	15
Afterword .....	17
Glossary .....	18

# Troubleshooting Tension

## FOCUS QUESTIONS

- How do elements on the machine, like a thread guide, impact tension?
- Why does bottom tension need to be established before the top tension?

## INTRODUCTION TO SEWING TENSION

In machine sewing, “Thread Tension” is the interaction of the top and bottom threads. The **top thread** runs from the cone or spool, through the machine thread guides and tensioners, to the needle. The **bottom thread** comes from the bobbin and wraps around the top thread to form a stitch.

With good thread tension, the top and bottom threads are balanced, pulling on each other evenly, with the **knots** tucked neatly into the center of the fabric layers.

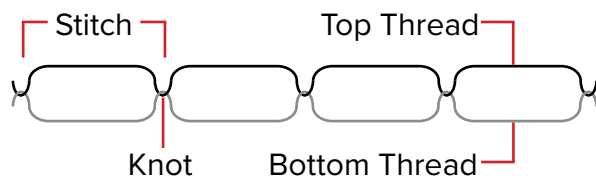

When the tension isn't balanced, the knots are pulled to all the way to the top or bottom layer of fabric. The quilt may pucker, and the stitches are less secure and may look sloppy.

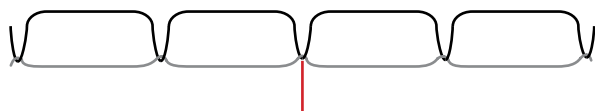

**Unbalanced Tension:** Knot pulled to one side of the fabric layers.

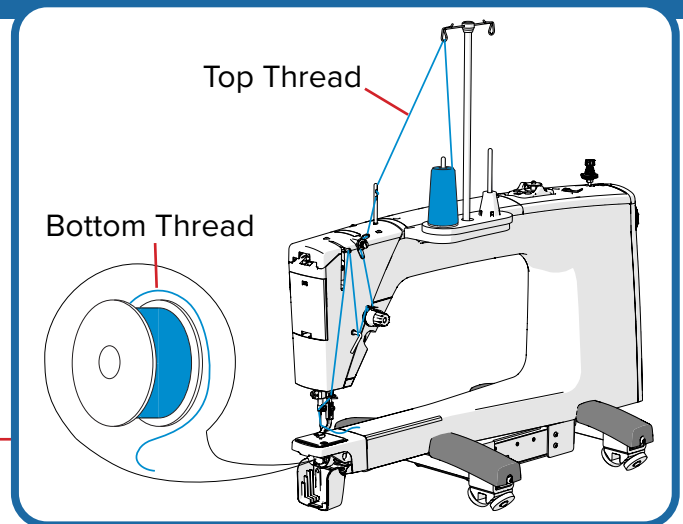

This guide aims to help you learn to balance your top and bottom thread to achieve good tension, and troubleshoot common tension issues that you may come across.

Remember, the first time you hopped on a bicycle you didn't have great balance right away. It took time to learn how to lean against the pull of gravity on the bike, to accommodate different terrains, and to move in different directions. That is where practice and patience come in.

## VOCAB REVIEW

**Top Thread:** The thread that is run from the cone or spool to the needle on the machine.

**Bottom Thread:** The thread that comes from the bobbin and is wrapped around the top thread to form a stitch.

**Knot:** The places at the start and end of a stitch where the bottom thread wraps around the top thread.

## WHAT INFLUENCES TENSION?

The top thread tension is controlled by the machine thread guides and tensioners. The bottom thread tension is controlled by the bobbin case and how the bobbin was wound.

The tension on both the top and bottom threads is influenced by the type and weight of the thread selected, the size of the needle, thickness of the batting, and other factors.

The thread and all the tension factors that come into physical contact with the thread are called the **direct tension factors**.

### Direct Tension Factors

These are factors that influence stitch quality or tension that directly contact the thread.

- The thread itself
- Thread guides properly threaded
- Cleanliness of thread guides, bobbin case, hook assembly, and needle plate
- Tension knobs
- Bobbin case
- Needle
- Fabric and batting (fabric tension)
- Bobbin wind tension

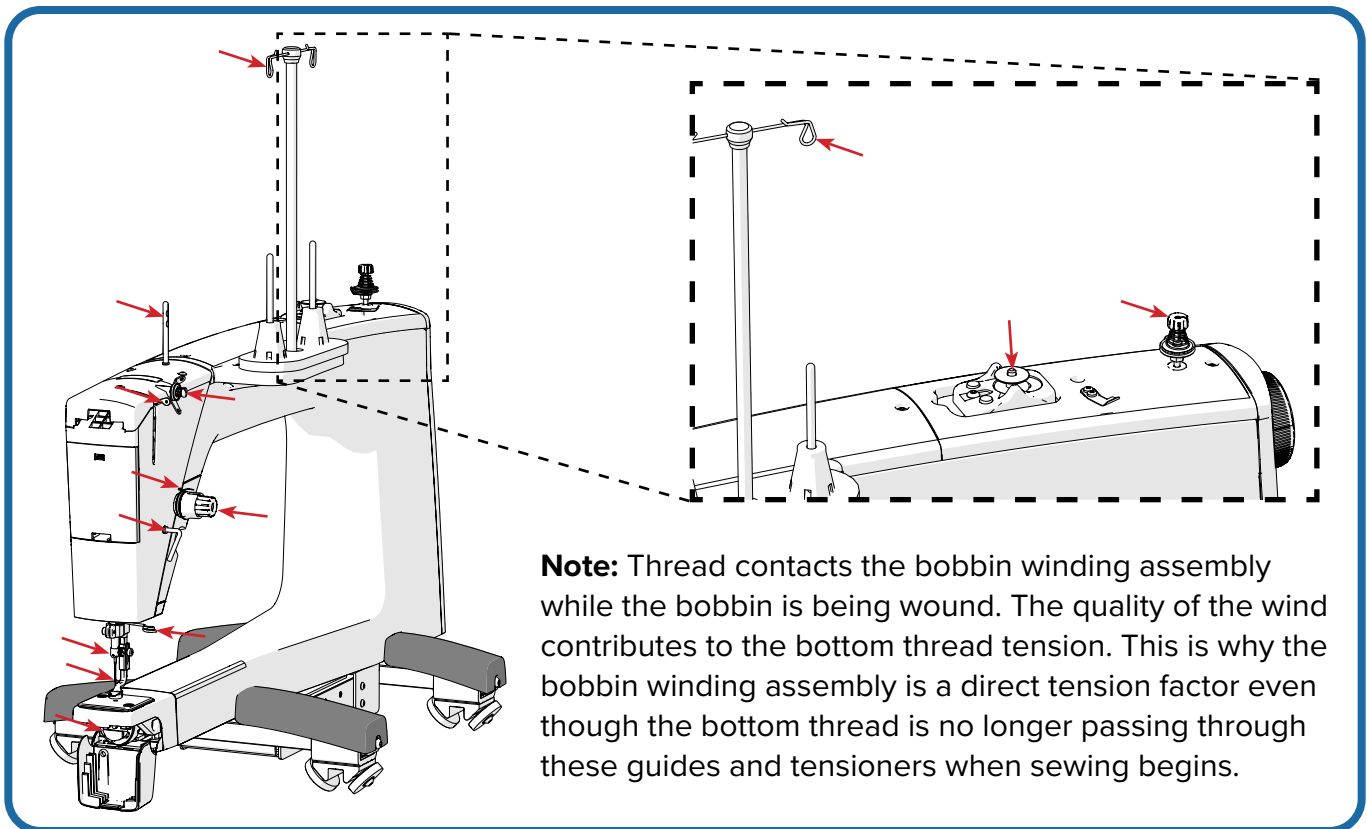

**Note:** Thread contacts the bobbin winding assembly while the bobbin is being wound. The quality of the wind contributes to the bottom thread tension. This is why the bobbin winding assembly is a direct tension factor even though the bottom thread is no longer passing through these guides and tensioners when sewing begins.

Some factors that impact stitch quality *do not* directly touch the thread, and may influence tension by changing the performance of the machine or frame. Examples include the height of the frame rails, the height of the hopping foot, and even the alignment of the tracks and carriage wheels. Factors that do not directly contact the thread are called **indirect tension factors**.

### Indirect Tension Factors

These are factors that influence stitch quality or tension without directly contacting the thread during sewing.

- Frame rail height
- Hopping foot height
- Cleanliness of tracks and wheels
- Track and wheel alignment

In the middle of quilting, indirect tension factors are easily overlooked. Check out our guide on Poor-Tension Prevention for a pre-quilting checklist that will help you remember before there's a problem.

Don't forget the final factor that influences stitch quality: you. The speed that you move the machine, the sharpness of your turns and corners, and the inconsistencies in your movements all affect stitch quality. While your skills will improve naturally over time with practice, keep in mind that the best stitch tension is achieved when the machine is moved slowly and consistently across the frame.

Lint buildup in your tensioners or hook assembly might not leap to mind when you think of "direct tension factors" but don't forget that anything that touches the thread can influence its tension. Keep your thread tensioners, guides, and the hook assembly area around the bobbin case clean.

## TENSION STRATEGY

---

Achieving good thread tension is about more than merely adjusting the top thread tension knob while quilting. Many tension factors come into play before the first stitch is made, so the key is to plan ahead.

- 1 Consider indirect tension factors first, as these are difficult to adjust once sewing has started:
  - Make sure your hopping foot and frame rail heights are set correctly.
  - Wipe down your tracks and machine wheels frequently with a damp (water only), lint-free cloth.
  - The alignment of the tracks and wheels was set when you assembled your machine and frame, so that is only a concern when troubleshooting stitch problems addressed later in this guide.
- 2 Next, consider the direct tension factors that impact the bottom thread:
  - Match your bobbin thread with your top thread unless using specialty thread. Then substitute thread of a similar weight in the bobbin.
  - Frequently clean the hook assembly, needle plate, and bobbin case.
  - Clean the bobbin thread tensioner and thread guides prior to winding your bobbin.
  - Wind the bobbin with care, and install it correctly into the bobbin case.
  - Take care installing the bobbin case into the machine.
- 3 Next, consider the direct tension factors that impact the top thread:
  - Make sure the needle is the correct size for the thread you are using.
  - Clean the thread guides and tensioners on your machine.
  - Thread the machine correctly.
  - Set the knob on the large thread tensioner to "1" to start.
  - On a scrap quilt made of the same materials as your work in progress, start stitching and slowly raise the tension. Stop frequently to look underneath the quilt for the bottom of the stitch. Sometimes tension can look perfect from the top and be a mess underneath.

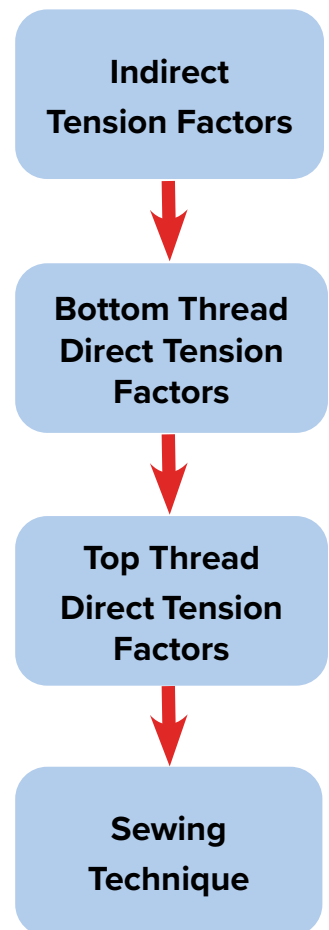

- 4 Once you're satisfied that the top thread tension is well balanced with the bottom tension, you can pull your practice quilt off the frame and install your current project. Focus on your technique as you get started:
  - Move slowly and steadily, especially at curves and corners.
  - Watch your tension as you work, keeping in mind that sometimes as the bobbin or thread cone run down, the top or bottom thread tension may change and you may need to use the top thread tensioner knob to accommodate those changes.
  - Every once in a while, check the back of the quilt just to make sure things are orderly.
  - Don't let stitches build up in one spot.

Other aspects of technique to consider:

- Pull up your bobbin thread at the start and end of stitching so thread tails don't get stitched into the back of the quilt.
- Set your needle to stop in the "down" position so that if you need to step away from your quilt you won't lose your spot.

## TENSION TROUBLESHOOTING

---

If you're still struggling with tension issues and adjusting the top thread tensioner knob isn't helping, there might be something wrong with one or more of the tension factors mentioned previously. To narrow down the cause, compare the stitches on the top of the quilt and those on the back. As a rule of thumb, issues on the quilt top indicate a problem with the bottom thread tension, while issues on the bottom of the quilt indicate an issue with the top thread tension. Issues on both sides need to be addressed in both the top and bottom tension or may have a different solution altogether.

Stitch issues showing up on the quilt backing indicate a problem with the top thread tension. Issues on the top usually result from problems with the bottom thread tension.

- Top Stitches Look Bad:..... See page 5
- Bottom Stitches Look Bad:..... See page 6
- Both the Top and Bottom Stitches Look Bad: .....See page 7
- My Thread is Breaking .....See page 15

## Only the Top Stitches Look Bad

Usually if the stitching looks bad on the top of the quilt, this indicates an issue with the bottom thread tension. It could mean that the bobbin was improperly wound, loaded incorrectly into the bobbin case, or just that the bobbin case tension is off.

Here is a list of common tension issues that can appear on the top of a quilt, and an explanation and solution list for each issue.

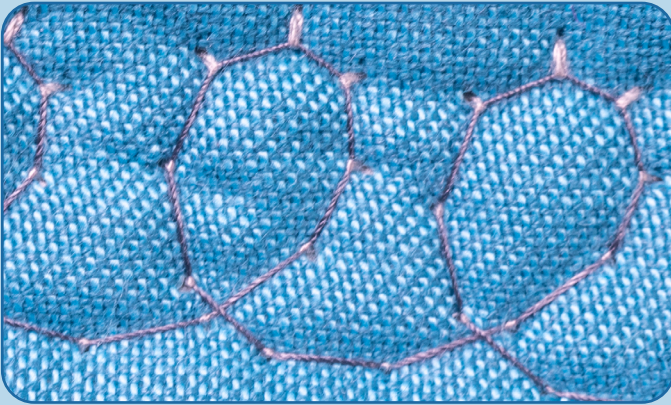

### **Eyelashing**

The bottom thread is being pulled up to the top layer of fabric, and it looks like your stitches have eyelashes. Eyelashing on the top of the quilt indicates an issue with the bobbin. Remove the bobbin from the case and re-install it. Check the bobbin case tension according to your machine's user manual. Re-install the case with care and reduce the top thread tension. If issue persists, see the bobbin case troubleshooting guide on page 10.

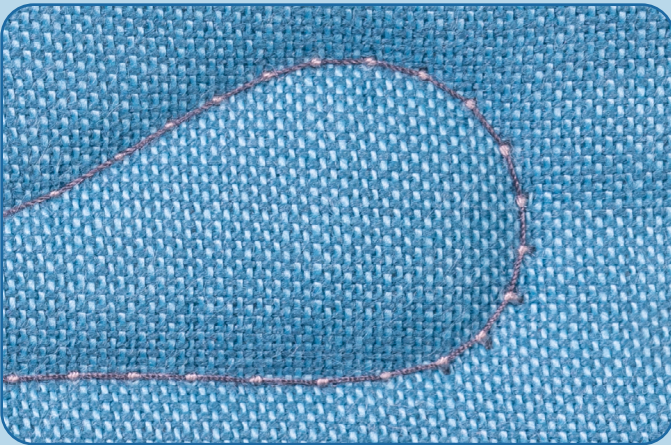

### **Railroad Tracks**

The top thread looks almost like it is laying flat across the surface of the quilt, with little points of the bottom thread crossing over it, like little railroad tracks. The tension on the top thread is too great, and the tension on the bottom thread too slack. Remove the bobbin from the case and re-install it. Check the bobbin case tension according to your machine manual. Re-install the case with care, and lower the top thread tension. If issue persists, see the bobbin case troubleshooting guide on page 10.

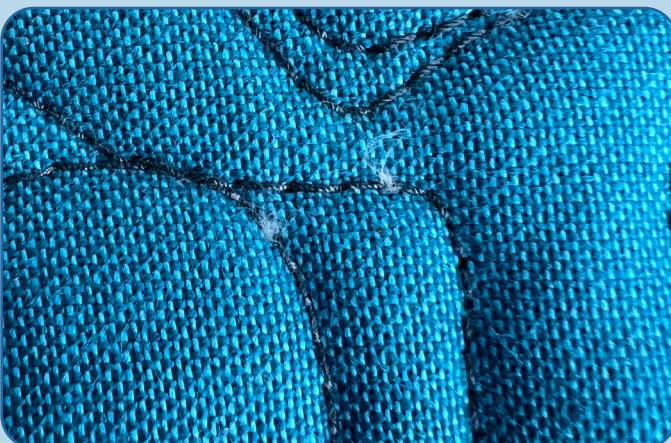

### **Bearding**

Bearding occurs when tufts of the batting material are pulled up through the top of the quilt. This happens when the batting has been installed with the scrim side up rather than down, or if there is a burr in the needle snagging the batting on the way back up.



## Only the Bottom Stitches Look Bad

When the tension problem is most obvious from the bottom of the quilt, this usually indicates an issue with how the machine is threaded. Here are common tension issues that can happen on the bottom of the quilt and what to do about them.

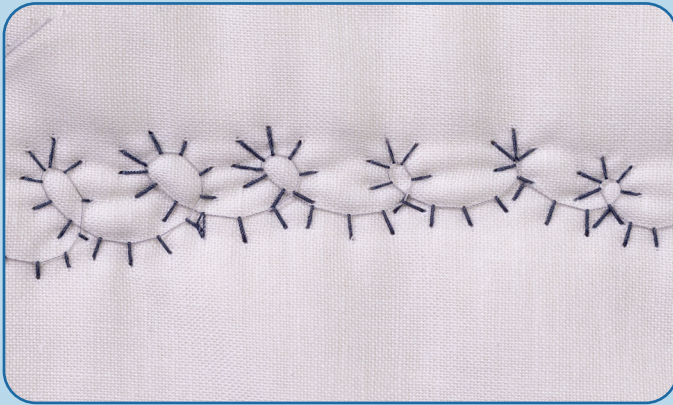

### Eyelashing

The top thread is pulled down to the opposite layer of fabric, and it looks like your line of stitching has suddenly grown eyelashes. When you have eyelashes on the bottom of the quilt, there is likely an issue with the threading on your machine. Check that the thread is fully flossed between the tension discs on both the small and large thread tensioner, and make sure the thread is hooked onto the check spring on the large thread tensioner. If the problem persists, check all the other top thread tensioners and guides, and tighten the top thread tension.



### Railroad Tracks

The bottom thread looks like it is lying flat against the back of the quilt, with the top thread crossing over it like railroad tracks. The top thread tension is too slack. Confirm the machine is threaded correctly, paying special attention to the check spring on the large thread tensioner. Confirm the needle is straight, sharp, and correctly positioned. Double-check your hopping foot height. Finally, increase the top thread tension. If the problem persists, reset your check spring tension. See “Resetting the Check Spring” on page 9 for details.



### Thread bunching

The thread is bunching up underneath the stitches due to excessive thread looping. This happens if the check spring on the large thread tensioner is bypassed when threading the machine, or if the thread was not flossed through the tension discs on the large and small thread tensioners. If the problem occurs only at the start of stitching, it could be that the bobbin thread tail coming out of the case is creating the looping. When installing the bobbin case into the machine, hold the tail toward you with your free hand.

## Both the Top and Bottom Stitches Look Bad

When the tension problem is obvious from both sides, that can mean there are tension issues on both the top and bottom threads, or the problem is something that affects both top and bottom thread at the same time.

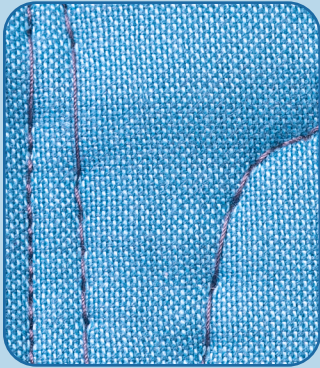

### Long Stitch

The encoders are not properly tracking the location of the machine on the frame, so stitch regulation isn't working. Confirm that both encoders are firmly plugged in. Gently lift the black wheel off the track. It should resist being pulled, and if it does not, see your instruction manual on proper encoder installation. If the encoder parts along the screw have been damaged, removed, or placed out of order, this could also cause issues. See your manual for instructions on replacing the encoder spring for details on the encoder parts.

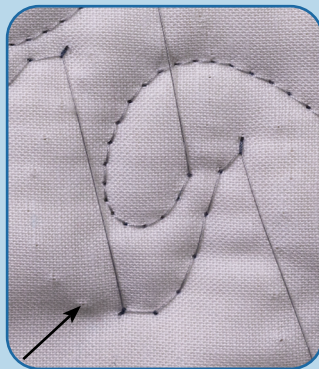
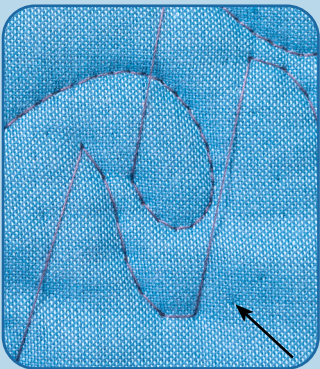

### Skipped Stitch

The machine attempted to make stitches, with the needle passing through the fabric, but the bottom thread didn't catch the top and the stitch wasn't completed. There are holes present where the stitch should be. Check the needle orientation and that the needle is straight. Also check your hopping foot height. Check that the machine threading is correct. Incorrect take-up rail height can also cause skipped stitches, as well as excessive top thread tension.

### Skipped vs. Long Stitch?

It can be tricky to tell the two of these apart without looking closely. A skipped stitch has a tale-tell hole (or series of holes) where the needle penetrated the fabric in an attempt to make a stitch. Look carefully along the path of your stitching for holes where the missing stitches should be.

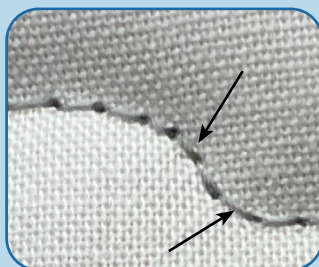
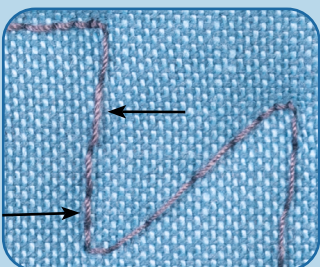

### Inconsistent Stitch Length

Some stitches are smaller or longer than others in regulated stitching. When this issue isn't caused by encoder issues (see long stitch above), it can be caused by jerky movements on the machine with sudden accelerations, especially when changing direction. Slow down and move smoothly.

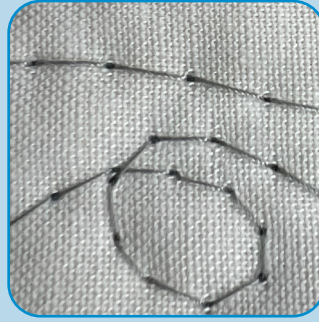

### Loose Stitches

Loose stitches occur when both the bottom and top thread are too loose. Stitches appear loose, and may catch easily on something passed over them. Increase the tension on the bobbin case first, and then try adjusting the top thread tension again, starting from 1.

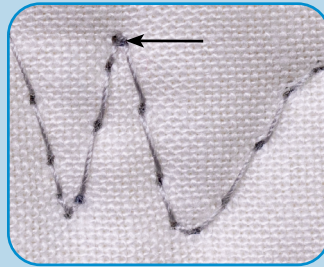
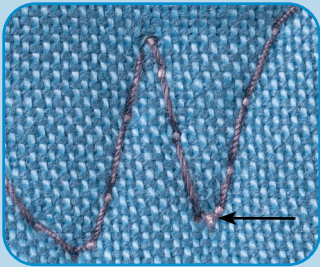

### Ball at Points/Stacked Stitches

The knot is formed improperly at points and sharp corners, creating bulky appearing stitches. This often happens when no batting is used. Slow down when quilting on thin layers. In a quilt of regular or bulky thickness, this occurs when the check spring is overly tight. See page 9 for steps on resetting the check spring.

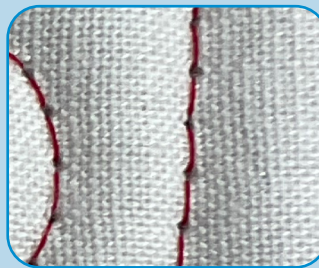
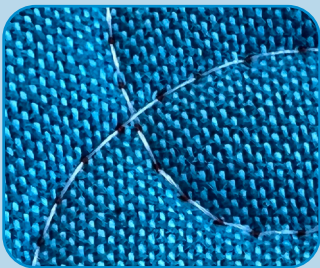

### “Pokey”

The thread from the opposite side of the fabric is “poking” through large holes at edge of each stitch. This occurs when a needle that is too large for the thread weight is being used. The thread does not fill the space made when the needle passes through the fabric. Swap out your needle for one of the correct size.

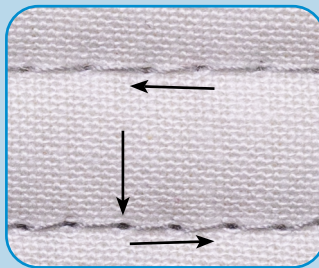
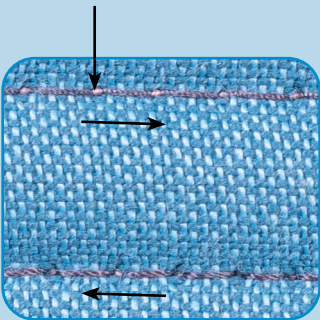

### Tension Changes With Direction Change

A tension issue may only show up when the machine is moved a certain direction. For example, railroading tracks may show up when moving the machine right to left, but not to the right. Correct the problem the same way you would if it were not direction-based. Also be sure to match your speed with the machine’s stitch rate. Pulling too hard can cause tension issues. Your bobbin may have been installed backward, or wound too loose.



### Puckered Fabric

Puckering fabric can be a sign that the top and bottom tension are too tight. Test your bobbin case tension and correct if necessary. Adjust top tension to balance changes made to bottom tension. If problem persists, the issue is likely with the fabric tension on the frame and not with the stitch tension.

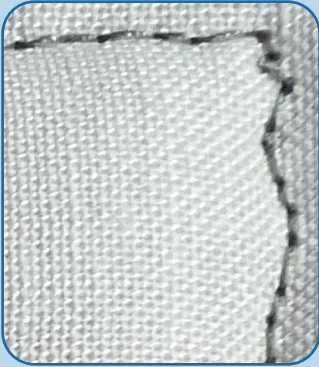

### Drunken Stitches

Stitches are coming out at odd angles instead of a straight line. This is usually caused by high vibration causing the needle to come down into the fabric where it normally shouldn't. Confirm the hopping foot height is correctly set, and that your needle is facing the correct direction. If you are using quilting automation, check the tension on your belts. If the problem persists, see your machine manual for instructions on aligning the wheels and your frame manual for instructions on aligning the tracks.

## RESETTING THE CHECK SPRING

If stitch tension issues persist on both sides of the quilt or on the bottom of the quilt after taking the other recommended troubleshooting steps, it may be that the check spring tension on your machine needs to be reset. Take the following steps:

- 1 Insert a small screwdriver into the end of the large thread tensioner until it passes into the metal slot.

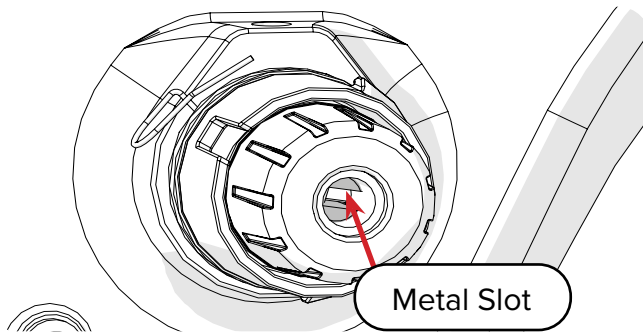

The large thread tensioner is located on the right side of your quilting machine, and its appearance may vary slightly depending on the model of your machine. If needed, see your machine manual to locate the large thread tensioner.

- 2 Turn the screwdriver counter-clockwise until the check spring starts to turn down.

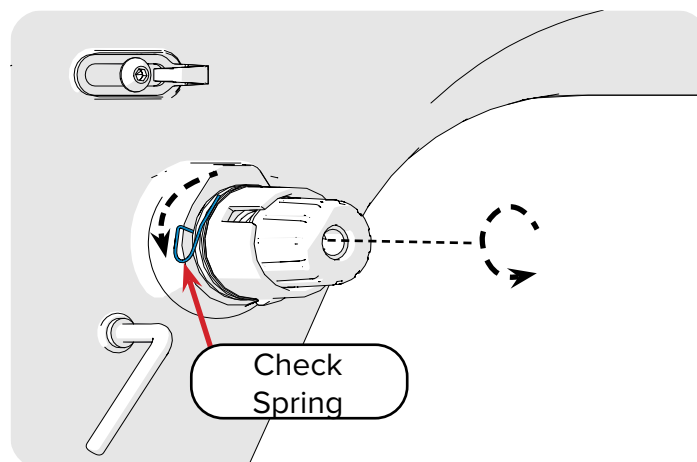

- 3 Turn the screwdriver clockwise until the check spring stops moving and then continue turning another 90 degrees. The check spring should still be at about a 45 degree angle to the ground.

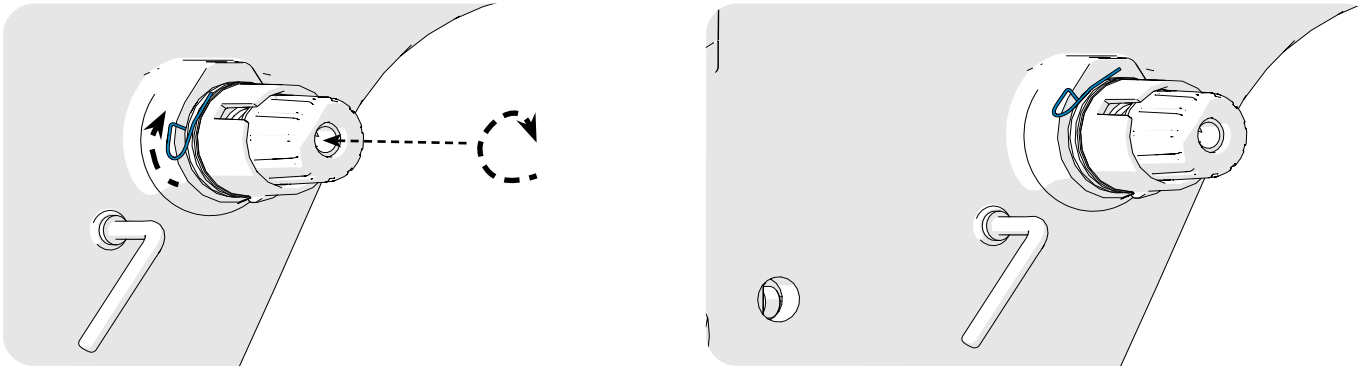

- 4 Press down on the check spring. It should move easily and spring back up when released.

## BOBBIN CASE TROUBLESHOOTING

If tension issues present on the top of the quilt persist even after the steps in “Only the top stitches look bad” section of this guide, it could indicate there is a problem with your bobbin case. Over time the bobbin case may wear out, or, if the case is dropped, the spring may fall out and be re-installed incorrectly. If the anti-backlash spring was bent or damaged, it will need to be replaced. This section of the guide will help you troubleshoot your bobbin case.

- 1 Place a bobbin in the bobbin case.

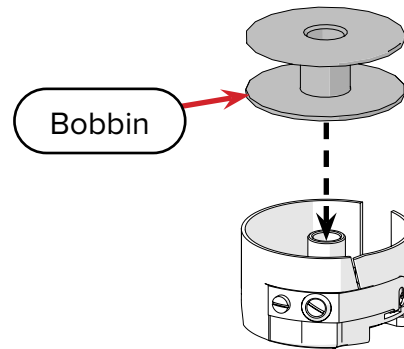

- 2 Look at the bobbin case from the side. The bobbin should barely poke out of the opening of the bobbin case. If the side of the bobbin is lifted clear over the edge of the case, the spring may not be installed correctly or may be damaged.

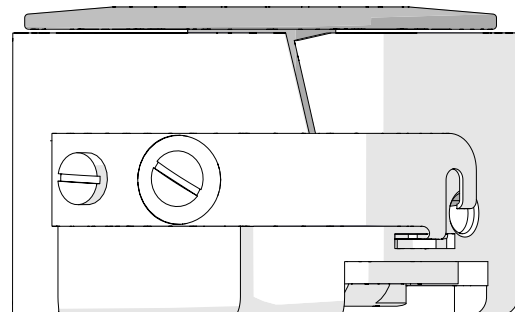
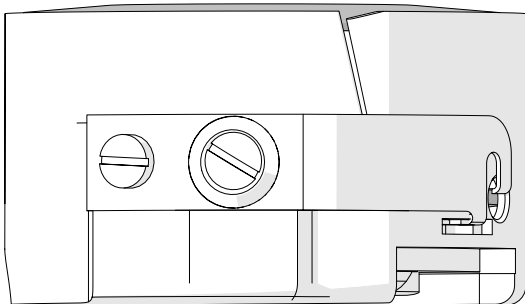

- 3 Tap the bobbin. It should bounce slightly. If it is not, the spring may be damaged or not installed correctly.

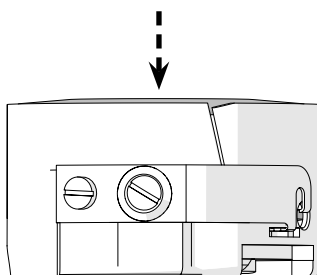

If the anti-backlash spring was installed incorrectly, carefully pull it from the bobbin case and take the following steps to correctly install it:

- 1 Lay the bobbin case face-down so that the opening is facing up.

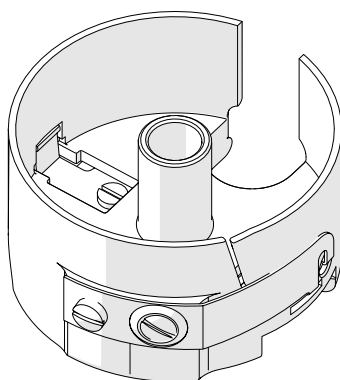

- 2 Position the anti-backlash spring so that the center section is raised above the outside of the spring.

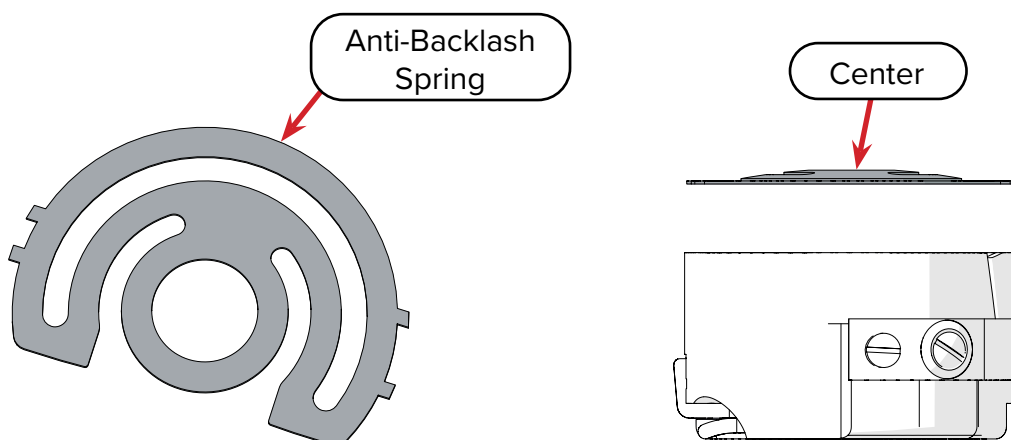

- 3 Place the spring inside the bobbin at an angle and press the tabs that are closer together into their slot on the side.

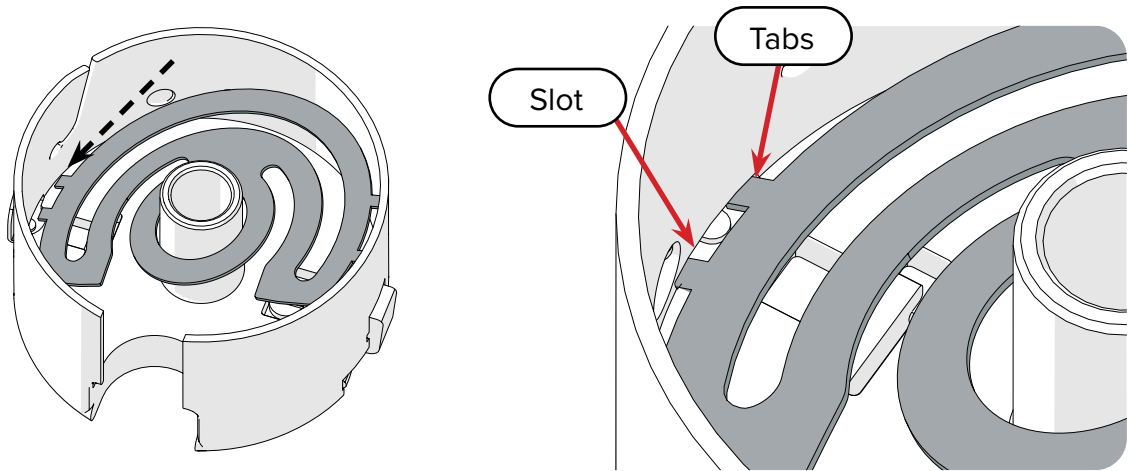

- 4 Press the other side of the spring down and insert the other tabs on the other side. Use the small flat-head screwdriver to make sure all four tabs are fully secured.

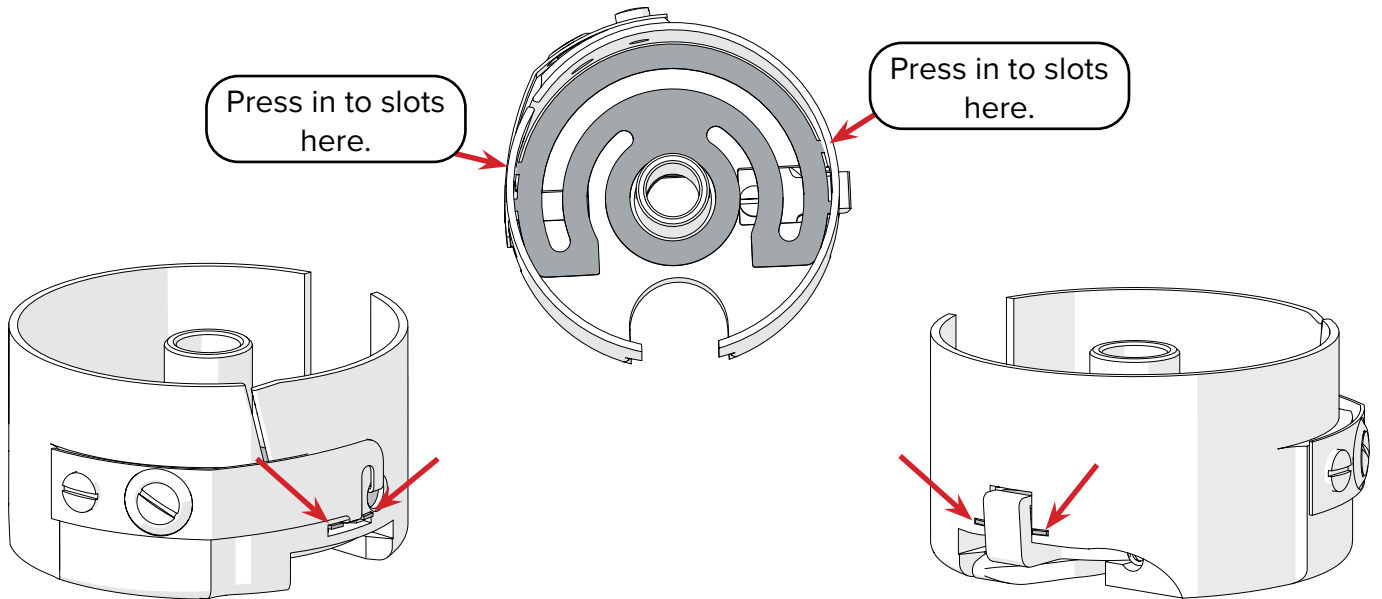

- 5 Test that the spring was installed correctly by repeating the bobbin case troubleshooting tests at the start of this section. If problem persists despite proper installation, the spring may be damaged and need replacing.

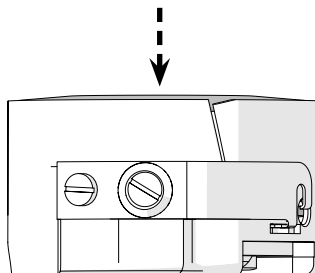

## BOBBIN WIND TROUBLESHOOTING

A properly wound bobbin, like the one shown to the right, has a smooth, even wind. It is wound fairly tight from start to finish, and not over-wound.

Watch your bobbin while it is filling to catch problems early. Some problems may not be obvious when the bobbin is fully wound.

**Coning** is when the thread fills more on one side during winding. This may cause your bobbin thread to break when sewing, or create tension issues that only appear when the machine is moving a specific direction.

Coning is often easier to spot early on during winding, as with the bobbins depicted below.

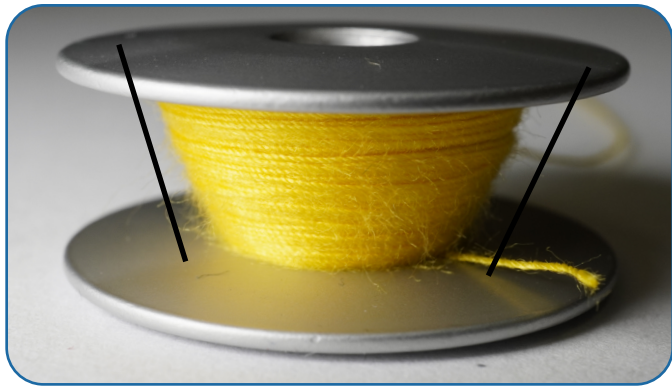

To fix coning, adjust the bobbin thread tensioner height to ensure the thread is winding at the correct angle. See your instruction manual's Bobbin Wind Troubleshooting section for instructions.

Another common issue is over filling. A bobbin is **over-wound** if it is filled past its brim. Pre-wound bobbins are often overfilled. An over-wound bobbin will create extremely tight bottom tension until the excess thread is used. This may cause the thread to break as well as make unseemly stitches.

Over-winding is fixed by unwinding the bobbin until the thread levels are appropriate. To prevent bobbins from overfilling in the future, adjust the fill levels of your bobbin winder. These instructions are covered in your machine's instruction manual.



**Over-wound:** To test if your bobbin is over-wound, place it vertically on a flat surface. If one of the sides of the bobbin is lifted up then the bobbin is over-wound. Keep in mind that many pre-wound bobbins are slightly over-wound.



**Properly Wound** - Bobbin wound evenly with tight tension on the winder.



**Loose winding** occurs when the bobbin thread tensioner is not putting sufficient tension on the thread as the bobbin is winding. A bobbin that is wound too loose may have dramatic tension changes from the start of the bobbin to its end, making it difficult to keep consistent thread tension as you quilt.

Sometimes a loosely wound bobbin doesn't look any different from a tightly wound bobbin. However, if you are able to peel down layers of the wound thread with your fingernail, the bobbin was likely wound too loose.



During a loose wind, stacks of the loose thread might get pinched under tighter strands or bulge out in places, creating a messy wind.

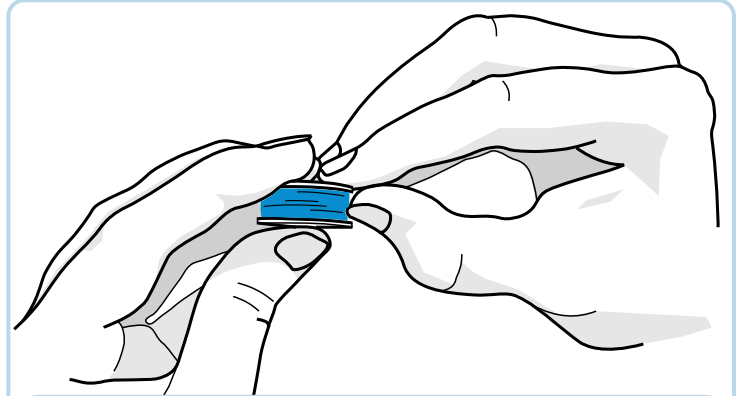
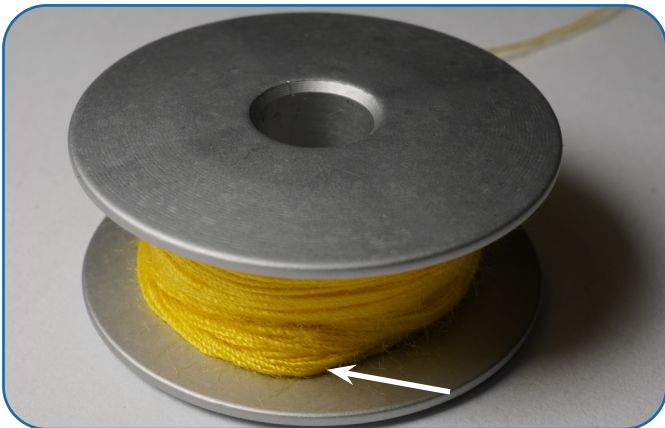

**Fingernail Test:** Press a fingernail between the thread layers in the bobbin to feel how tightly a bobbin was wound. Practice frequently to develop a sense for when a bobbin is wound tightly enough.

## VOCAB REVIEW

**Coning:** The thread is winding more to one side of the bobbin than the other.

**Over-wound:** The bobbin has been filled past the edges of the sides.

**Loose Wind:** The tension of the bobbin thread tensioner was not tight enough when the bobbin was wound.

## TROUBLESHOOTING BREAKING THREAD

The sewing machine thread can break when too much tension causes the thread to snap, which is called a **tension break**. Thread can snag on a burr on the thread guides, needle plate, or other parts of the machine and tear. Misalignment of machine parts (such as the needle) can also slice the thread.

When your thread keeps breaking, take note of the speed and direction the machine is moving in. Note if the thread consistently breaks at a certain speed or direction. Also determine whether the top or bottom thread broke. If the break is caused by a burr, knowing which thread broke can help you determine where the burr is.

Narrow down the cause of breaking thread by looking at the broken ends of the thread. Different types of breaks often look different, as shown in the next three photos. Keep in mind, however, that specialty threads and single-ply threads may not resemble the examples below when they break.



**Tension Break:** too much tension caused the thread to snap.

If the broken end looks shredded or coiled there may be a burr somewhere on the machine that is cutting the thread.

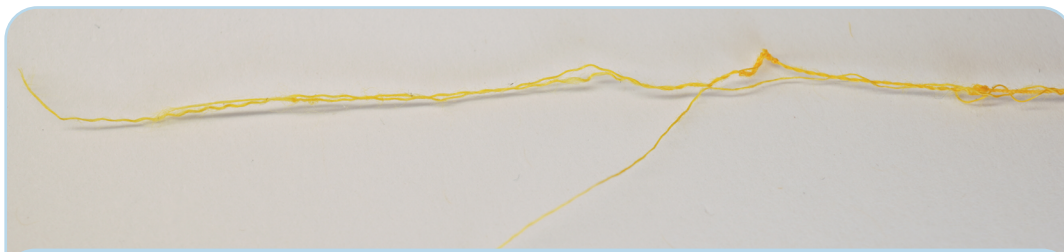

**Long Frayed Break:** a burr along the thread path snagged and ripped the thread.

A burr can also cause a clean cut on thread, but this isn't as common. Usually a clean cut happens when the needle is positioned at an angle, allowing the hook to slice the thread during stitch formation.

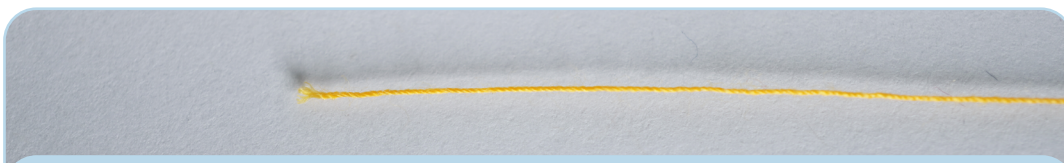

**Clean Break:** often caused by poor needle orientation or a bent needle.

### Common Causes of Breaking Thread

Poor Thread Quality / Old Thread



Sewing Technique (Slow down)



Excessive Tension (loosen top and bottom)



Hopping Foot or Frame Rails Misaligned



Bent Needle and Incorrect Needle Orientation



Machine Threaded Incorrectly

## Tension Break

Tension breaks occur when both the top and bottom thread tension are so tight that the thread snaps. The thread tension may be too tight in the bobbin case and the large thread tensioner, or other factors might be increasing the tension.

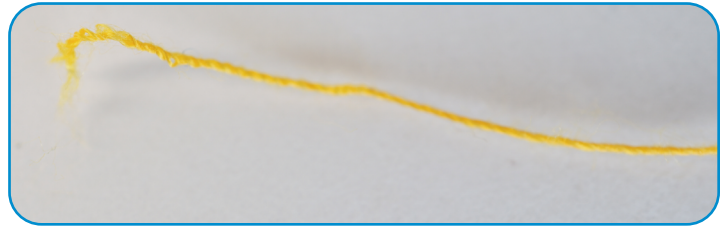

Here are the steps to troubleshoot a tension break:

- Test the strength of your thread. Thread weakens as it ages, so consider switching out thread that you've had for longer than a year. Also note that cotton thread breaks more easily than polyester, and two ply threads break more easily than three ply threads.
- Sometimes slowing down the speed that you're stitching can correct the issue. This is especially true if you're using specialty thread that snaps easily under tension.
- Make sure that your machine is threaded correctly. Pay special attention to thread that may have gotten looped or twisted around something that it shouldn't have.
- Consider when you last cleaned your machine. Lint build-up in the tensioners and thread guides can create extra friction.
- Check your bobbin case tension, and how the bobbin is oriented in the case. Keep in mind that certain kinds of thread will create more friction going through the case, so it's always important to re-test your tension every time you change out the bobbin.
- Confirm that your needle is installed correctly based on the instructions in your machine's manual. A misaligned needle can create a tighter knot during stitch formation.
- Confirm that your hopping foot height is set correctly. The hopping foot holds down the fabric when a stitch is made. Slipping fabric may pull at the thread and cause it to snap.
- Check your frame's rail height and the fabric tension. Excessive fabric tension or the angle that the fabric is held by the rails may cause the fabric to pull at the thread.
- If you've had your check spring or large thread tensioner assembly replaced or adjusted, the check spring position can cause the thread to break. Make sure the check spring is at a 45 degree angle.
- After checking your bottom thread tension, reset your top tension to "1" and increase it slowly until your tension is correct.

## Long Frayed Break

While a tension break may appear frayed, the frayed edges of the long frayed break usually span over a few inches of thread. The most common cause of a long frayed break is a burr on the thread guides, tensioners, needle, needle plate, hook assembly, bobbin case, or bobbin. Any part of the machine that physically contacts the thread may have a burr on it that could cause the thread to tear and eventually break.

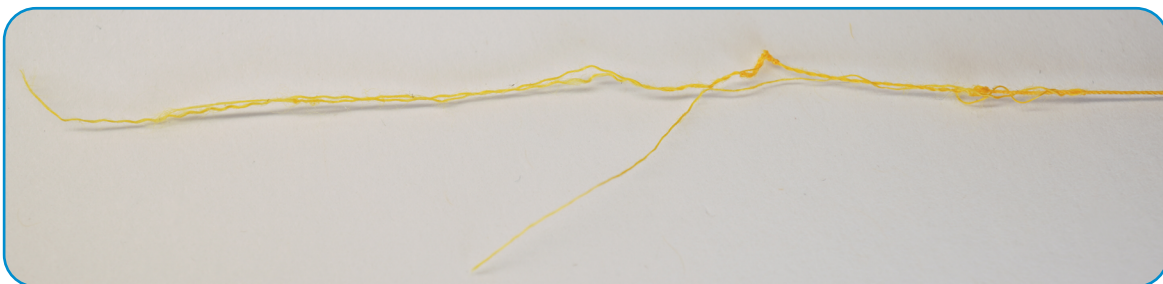

It's also possible for a loose ply thread to rip apart this way, so consider switching if you're using a specialty thread that isn't tightly spun.

**To find burrs:** check the pathway that the thread takes along the machine if it is the top thread, or check the bobbin and bobbin case if it is the bottom thread. A good strategy is to floss the thread around each of the tensioners or anywhere that thread comes into contact with to try to feel out any snagging or ripping. The burr may also be in the hole in the needle plate. Try flossing some thread through that hole to check for a burr (take the needle out for this step. You don't want to jab yourself).

If the bottom thread is breaking, carefully feel for burrs along the edges of your bobbin case. Floss thread through the thread path as well.

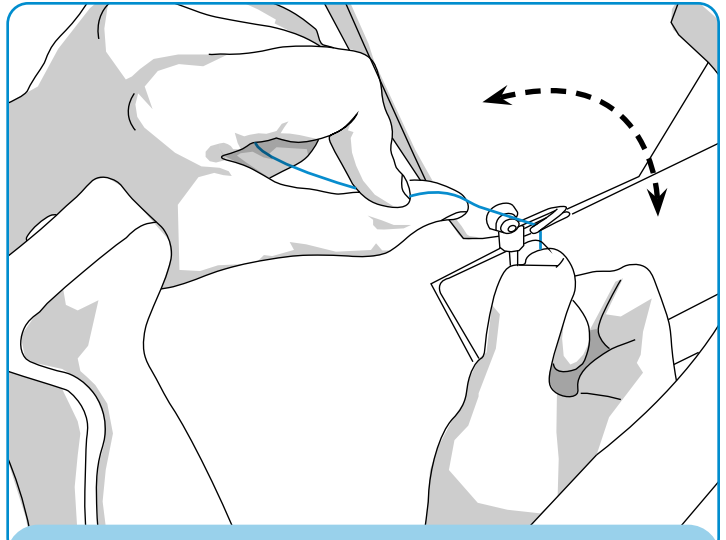
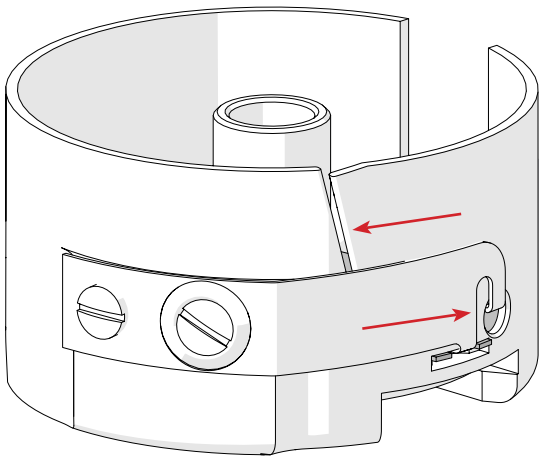

**Burr Check:** Floss thread around the thread guides and feel for burrs. Thread guides will vary by machine model, so check your manual for information on threading your machine.

You'll also need to check that your needle is not damaged, and that it is properly oriented. See your machine's instruction manual for information on the needle position.

If a burr is discovered, the part that the burr is on will likely need to be replaced. Call Grace Company tech support for assistance.

### Clean Break

A clean cut break usually means that something very sharp is slicing the thread. If the needle is bent or oriented improperly, it can position the thread so that the hook assembly slices across it.

Occasionally a burr on any of the thread tensioners and guides or hook assembly and bobbin case can be sharp enough to create a clean slice through the thread. Use the flossing method described in the "Long Frayed Break" section to test for burrs. Parts found to have burrs may need to be replaced with the assistance a Grace Company support technician or dealer.

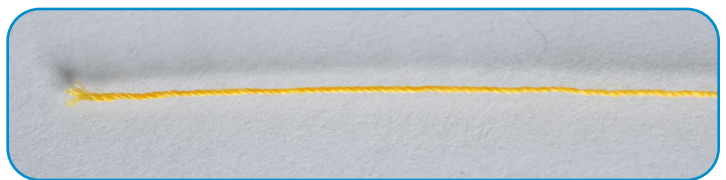

## AFTERWORD

Be patient with yourself and mindful of your quilting setup and mastering tension will be within your reach. Create a list to help you with any troubling areas that slip your mind and keep it with the reference cards that came with your frame or machine. Try not to get discouraged or overwhelmed! Any type of learning takes time, practice, and self encouragement.

**Bottom Thread**

The thread that comes from the bobbin and is wrapped around the top thread to form a stitch.

**Clean Break**

A type of thread break often caused by poor needle orientation or a bent needle.

**Coning**

The thread is winding more to one side of the bobbin than the other.

**Direct Tension Factors**

These are factors that influence stitch quality or tension that directly contact the thread.

**Indirect Tension Factors**

These are factors that influence stitch quality or tension without directly contacting the thread during sewing.

**Knot**

The places at the start and end of a stitch where the bottom thread wraps around the top thread.

**Long Frayed Break**

A type of thread break where a burr along the thread path snags and rips the thread.

**Loose Wind**

The tension of the bobbin thread tensioner was not tight enough when the bobbin was wound.

**Over-wound**

The bobbin has been filled past the edges of the sides.

**Tension Break**

Too much tension caused the thread to snap.

**Top Thread**

The thread that is run from the cone or spool to the needle on the machine.

## NOTES

---





[www.graceframe.com](http://www.graceframe.com)

1-800-264-0644