

Q'nique 16 X MANUAL

Instruction Manual



Important Safeguards

When using an electrical appliance, basic safety precautions should always be followed, including the following.

DANGER - To reduce the risk of electric shock, do not leave the machine unattended when plugged in. Always unplug this machine from the electric outlet immediately after using and before cleaning.

WARNING - To reduce the risk of burns, fire, electric shock, or injury to persons:

- This appliance is not to be used by persons (including children) with reduced physical, sensory, or mental capabilities, or lack of experience and knowledge, unless they have been given supervision or instruction concerning use of the appliance in a safe way and understand the hazards involved.
- Children should be supervised to ensure that they do not play with the appliance. Children shall not play with the appliance.
- Cleaning and user maintenance shall not be made by children without supervision.
- Use this machine only for its intended use as described in this manual. Use only attachments recommended by the manufacturer as contained within this manual.
- Never operate this machine if it has a damaged cord or plug, it is not working properly, or it has been dropped, damaged, or dropped into water. Return the machine to the nearest authorized dealer or service center for examination, repair, or electrical or mechanical adjustment.
- Never operate the machine with any air openings blocked. Keep ventilation openings of the quilting machine free from the accumulation of lint, dust, and loose cloth.
- Never drop or insert any object into any opening.
- The appliance is intended for indoor use only. Do not use outdoors.
- Do not operate where aerosol (spray) products are being used or where oxygen is being administered.
- Connect this appliance to a properly grounded outlet only. See grounding instructions on next page.
- To disconnect, turn all controls to the off position, then remove the plug from the outlet by grasping the plug. Do not pull on cord. Always switch off or unplug the appliance when leaving it unattended.
- Do not unplug by pulling on cord. To unplug, grasp the plug, not the cord.
- If the supply cord is damaged, it must be replaced by the manufacturer, its service agent or similarly qualified persons in order to avoid a hazard.
- Keep fingers away from all moving parts. Special care is required around the quilting machine needle.
- Always use the proper needle plate. The wrong plate can cause the needle to break.
- Do not use bent or damaged needles.
- Do not pull or push fabric while stitching. It may deflect the needle, causing it to break.
- Switch the quilting machine off when making any adjustments in the needle area, such as threading the needle, changing the needle, or changing the presser foot, etc.
- Always unplug the quilting machine from the electrical outlet when removing covers, lubricating, or when making any other user servicing adjustments mentioned in the instruction manual.
- CAUTION: In order to avoid a hazard due to inadvertent resetting of the thermal cut-out, this appliance must not be supplied through an external switching device, such as a timer, or connected to a circuit that is regularly switched on and off by the utility.

If using this machine in an area with inconsistent input power, it is recommended the surge protector is connected to a backup battery supply.

SAVE THESE INSTRUCTIONS!

Do not discard box or packaging.

GROUNDING INSTRUCTIONS

This product must be grounded. In the event of malfunction or breakdown, grounding provides a path of least resistance for electric current to reduce the risk of electric shock. This product is equipped with a cord that has an equipment-grounding conductor and a grounding plug. Plug the cord from the quilting machine into a surge protector. The surge protector must be plugged into an appropriate outlet that is properly installed and grounded in accordance with all local codes and ordinances.

DANGER - Improper connection of the equipment-grounding conductor can result in a risk of electric shock. The conductor with insulation having an outer surface that is green, with or without yellow stripes, is the equipment-grounding conductor. If repair or replacement of the cord or plug is necessary, do not connect the equipment-grounding conductor to a live terminal. Check with a qualified electrician or serviceman if the grounding instructions are not completely understood, or if in doubt as to whether the product is properly grounded.

Do not modify the plug provided with the product - if it will not fit the outlet, have a proper outlet installed by a qualified electrician.

Grounding Methods

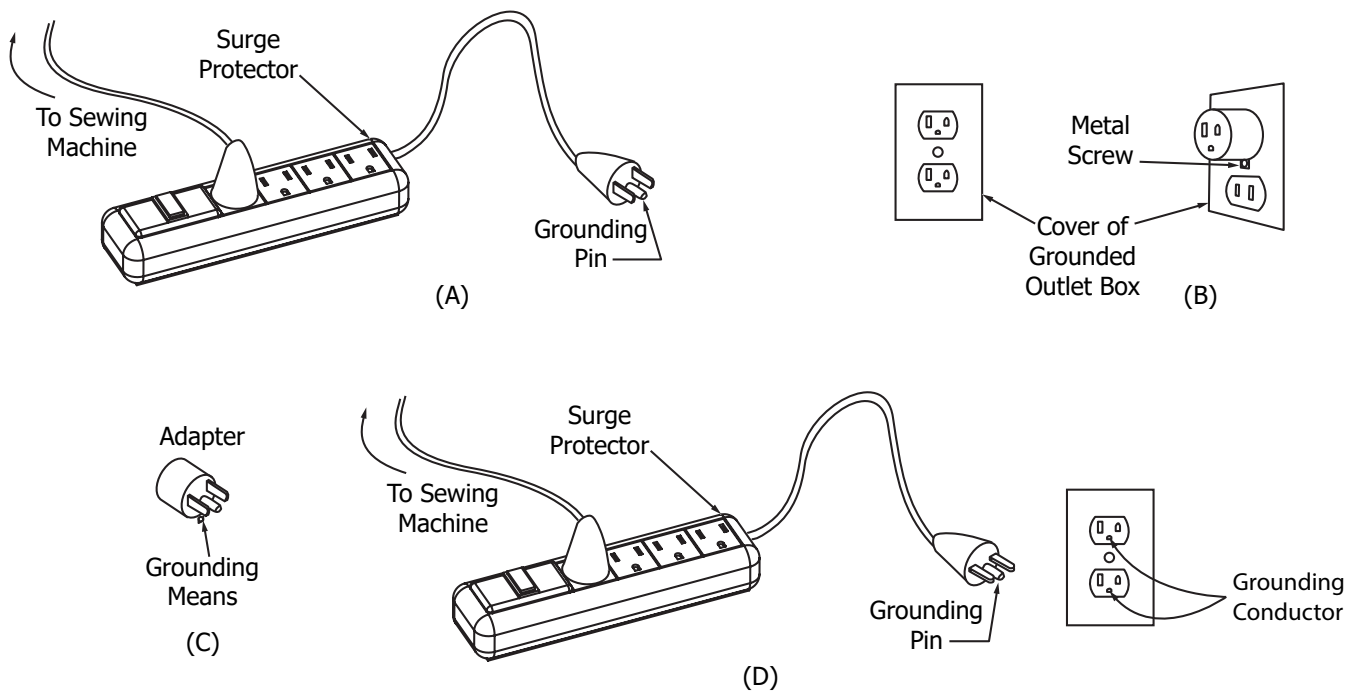

This product is for use on a nominal 120 V circuit, and has a grounding pin as illustrated above (A). A temporary adapter, shown in (B) and (C), may be used to connect this plug to a 2-pole receptacle (B) if a properly grounded outlet is not available. The temporary adapter should be used only until a properly grounded outlet can be installed by a qualified electrician. The green colored rigid ear, lug, and the like, extending from the adapter must be connected to a permanent ground such as a properly grounded outlet box cover. Whenever the adapter is used, it must be held in place by the metal screw.

A qualified electrician should be consulted if there is any doubt as to whether an outlet box is properly grounded.

Table of Contents

Important Safeguards	i
Table of Contents.....	iii
Machine Specifications	iv
Machine Layout	v
Ports and Plug-Ins	vii
My Machine Details.....	ix
Included Parts and Tools	x
Welcome to Your Q'nique 16X Manual	1
Animated Instructions	3
Out-of-the Box Assembly	3
Part One	4
Task 1 - Prepare Frame for the Machine	5
Part Two	6
Task 2 - Installing the Wheels.....	7
Part Three.....	12
Task 3 - Installing the Handlebars	13
Task 4 - Attaching the Thread Stand	16
Task 5 - Turning the Machine On/Off.....	17
Preparing to Quilt	18
Task 6 - Winding a Bobbin.....	19
Task 7 - Loading the Bobbin Case	22
Task 8 - Threading the Machine	24
Part Four.....	30
Quilting	31
Using the Handlebar Controls	32
Adjusting Thread Tension	33
Getting Started.....	36
Maintaining the Machine	40
Preparing the Oil Bottle	41
Oiling and Cleaning.....	42
Changing the Needle.....	46
Adjusting the Hopping Foot	48
Reinstalling the Needle Plate	51
Reinstalling the Anti-Backlash Spring.....	53
Repairs and Diagnostics	55
Reinstalling the Hook Holder.....	56
Timing the Machine	59
Appendix.....	63
Choosing Your Needle	64
Choosing Your Thread.....	66
Choosing Your Fabric and Batting.....	69
Troubleshooting Guide	70
Index.....	72

Machine Specifications

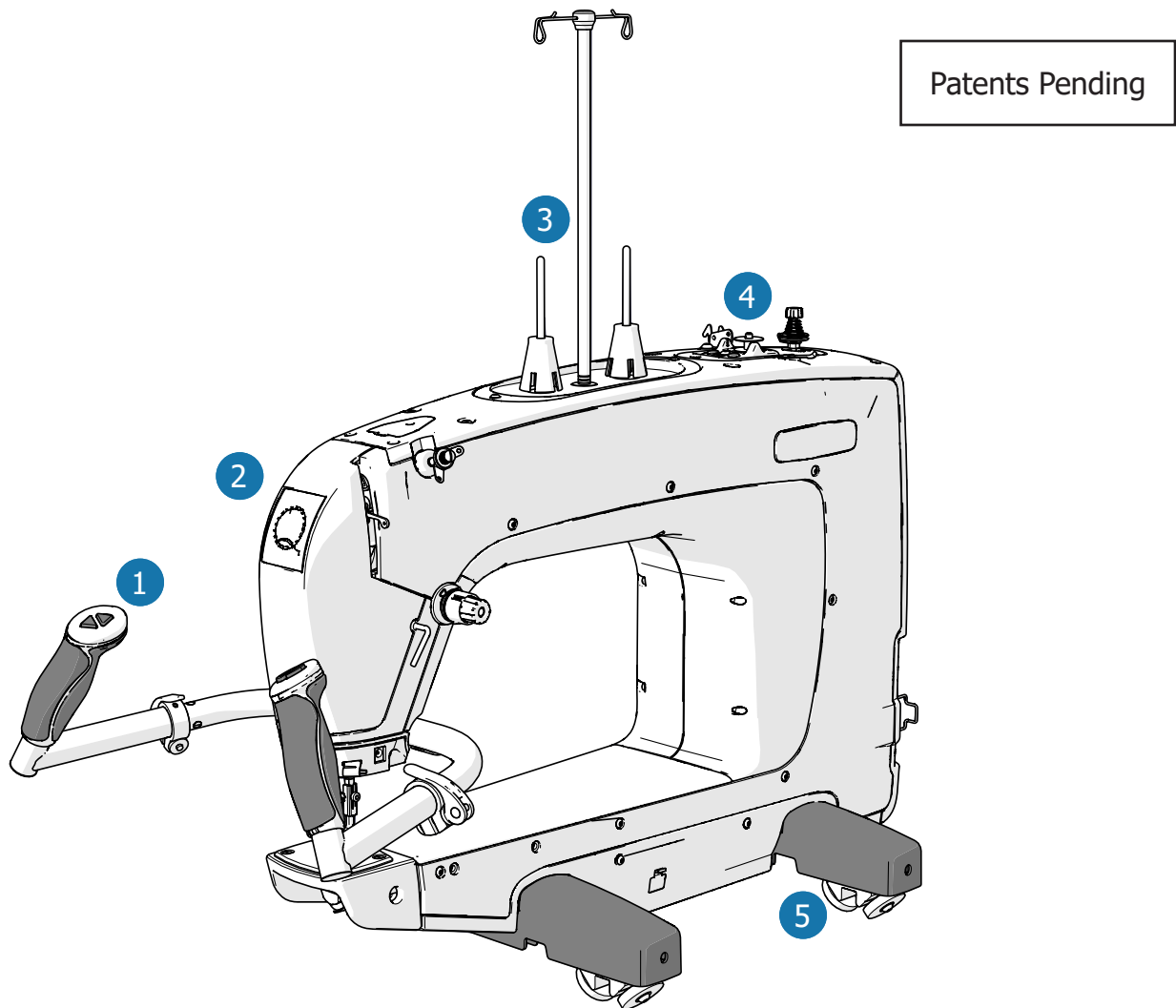

Product Dimensions

Body:

- Height: 781.05 mm, or 30.75 inches
- Width: 381 mm, or 15 inches
- Length: 820 mm, 32.3 inches
- Weight: 21.5 kg, or 47.5 lbs

Quilting Arm:

- Height: 210.8 mm, or 8.3 inches
- Length: 406.4 mm, or 16 inches

Electrical

- Input Voltage: 115/230 VAC
- Peak Power Consumption: 200 W

Features

- 1 Adjustable handles for comfortable extended use (page 13)
- 2 Q-Display (page 32)
- 3 Dual thread mast and stands for quilting and winding bobbin at the same time
- 4 Built-in bobbin winder (page 19)
- 5 Dual wheels for stability (page 7)
- Stitches per minute (SPM) range of 90 to 1700 stitches

Machine Layout

Quilting Machine (Front View)

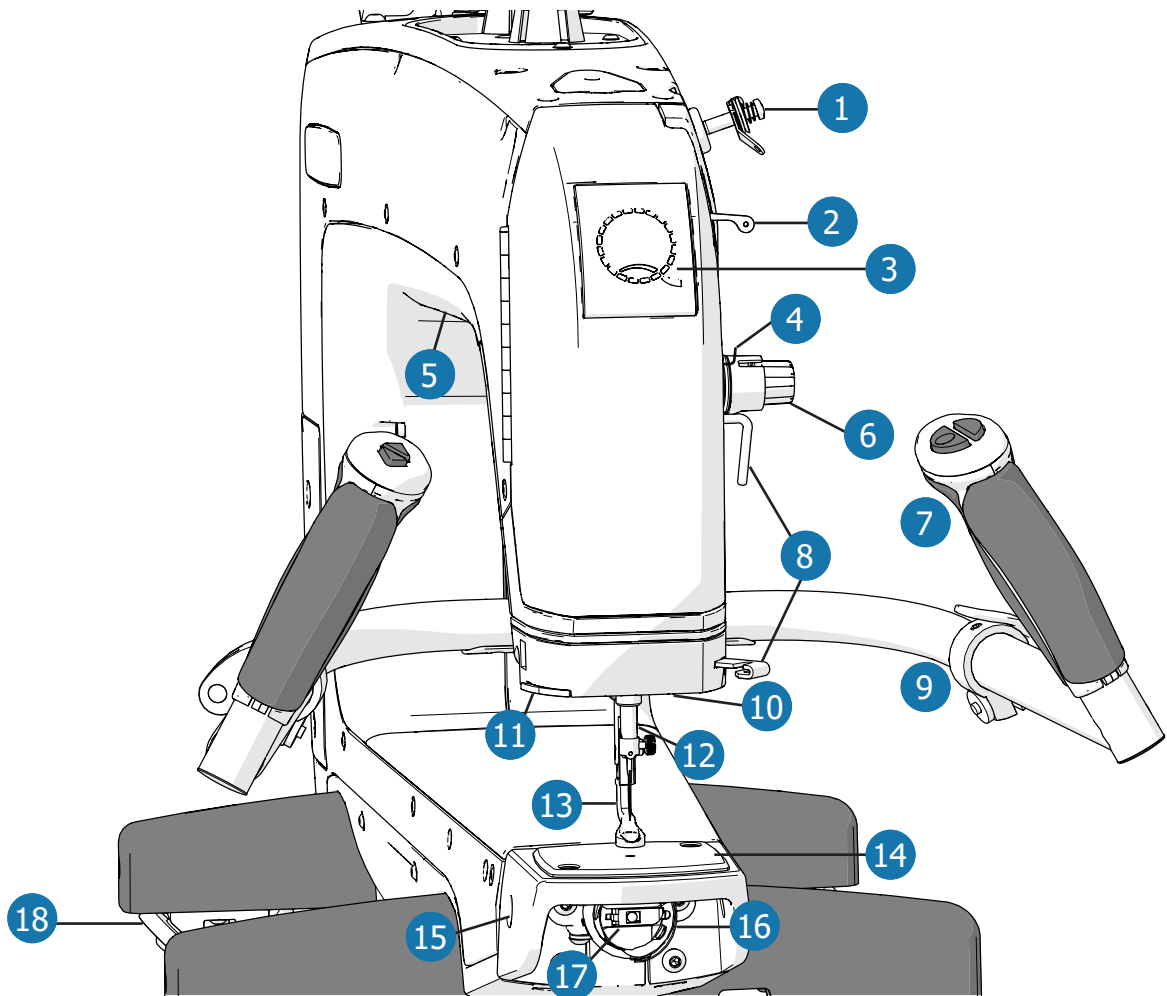

- 1 Small Thread Tensioner** (page 24)
Tensions thread when quilting.
- 2 Take-Up Lever** (page 24)
Tensions thread when quilting.
- 3 Q-Display** (page 32)
Visual display to show stitching speed.
- 4 Tensioner Check Spring** (page 24)
Applies additional tension to thread.
- 5 Throat Lights**
Lights up sewing area when machine is on.
- 6 Large Thread Tensioner** (page 24)
Tensions thread as adjusted when quilting.
- 7 Handlebar Controls** (page 32)
Controls machine functions.
- 8 Thread Guides** (page 24)
Positions thread when quilting.
- 9 Handle Bar Levers** (page 13)
Used to adjust handle position.
- 10 Lamp**
Lights up needle area when machine is on.
- 11 Thread Cutter** (page 24)
Cuts excess thread from threading machine.
- 12 Needle Bar** (page 24)
Holds the needle when quilting.
- 13 Hopping Foot** (page 48)
Presses fabric down when quilting.
- 14 Needle Plate** (page 51)
Covers top of hook assembly.

- 15 **Timing Cut-Out** (page 59)
Accesses hook assembly set screws.
- 16 **Hook Assembly** (page 19)
Holds the bobbin case and hooks the top thread to create stitches.

- 17 **Bobbin Case** (page 19)
Holds M class bobbin and controls bottom thread tension.
- 18 **Machine Wheels** (page 7)
Shuttles the machine up and down the bottom carriage.

Quilting Machine (Top View)

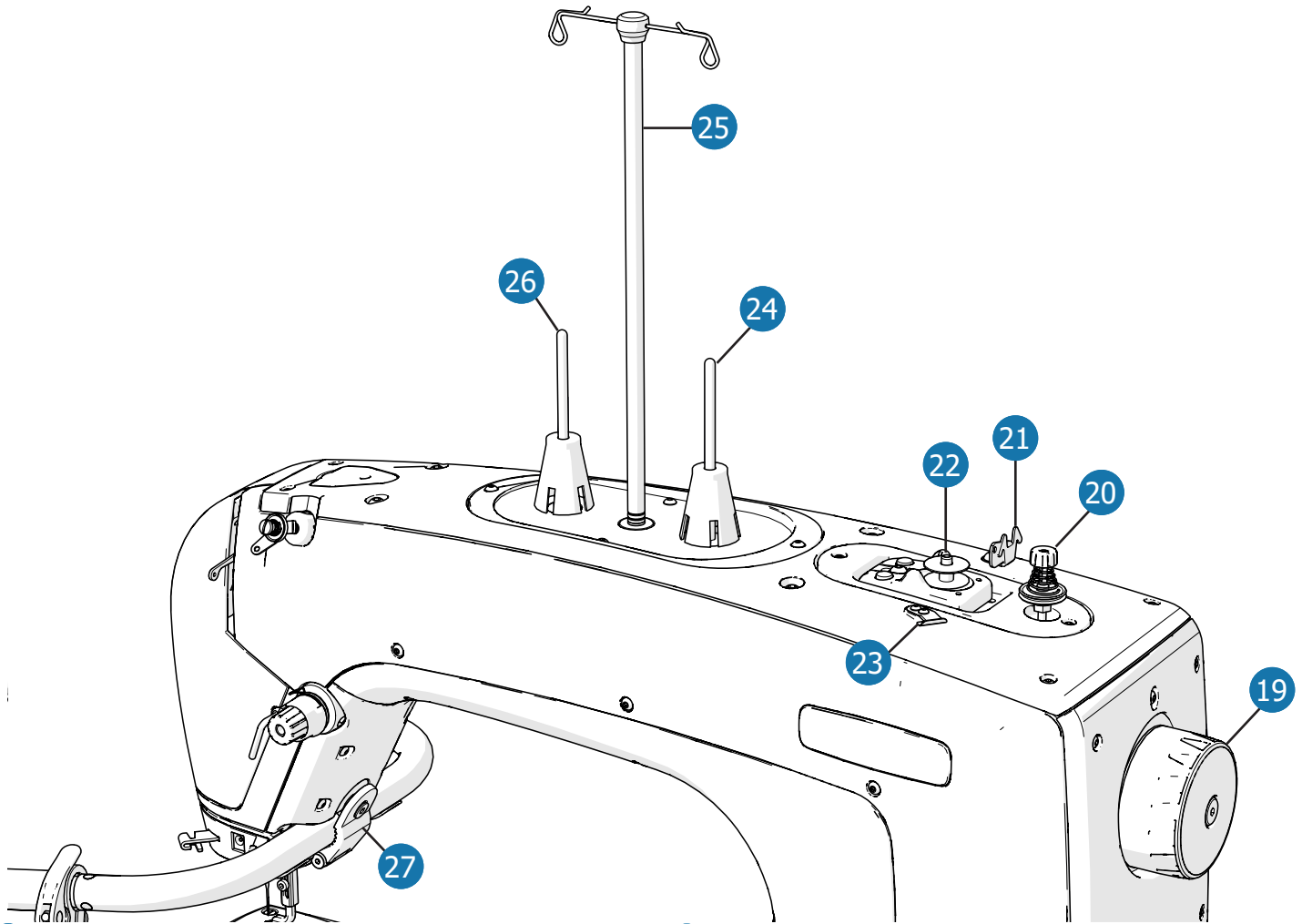

- 19 **Hand Wheel**
Raises and lowers the needle bar.
- 20 **Bobbin Thread Tensioner** (page 19)
Tensions thread when winding a bobbin.
- 21 **Bobbin Thread Guide** (page 19)
Guides thread to the bobbin thread tensioner.
- 22 **Bobbin Stand** (page 19)
Holds the bobbin for winding.
- 23 **Bobbin Thread Cutter** (page 19)
Cuts wound bobbin thread.
- 24 **Bobbin Winder Thread Stand** (page 19)
Holds a cone of thread for winding bobbin.
- 25 **Thread Mast** (page 16)
Guides thread when quilting.
- 26 **Top Thread Stand** (page 24)
Holds a thread cone for threading machine.
- 27 **Handle Bar Clamp** (page 13)
Used to adjust handlebar position.

Ports and Plug-Ins

Machine Rear (Rear View)

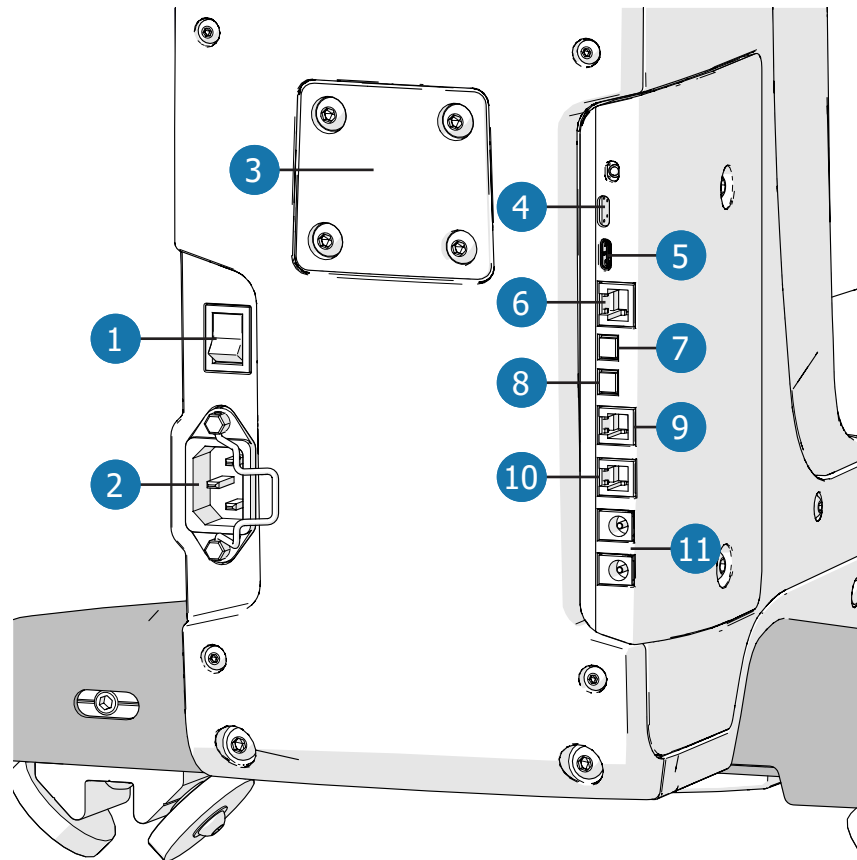

- 1 Power On/Off Switch** (page 17)
Turns machine on and off.
- 2 Power Port with Retainer** (page 17)
Connects and holds power cable to the machine.
- 3 Back Handle Mount Cover**
For mounting the back handle accessory.
- 4 USB Connector Port**
For 7 inch back handles display and for updating.
- 5 USB Connector Port**
For 2.4 inch back handles display.
- 6 Quilt Motion Tablet Port**
For optional automation accessory.
- 7 Left Rear Handle Cable Port**
For back handle accessory.
- 8 Right Rear Handle Cable Port**
For back handle accessory.
- 9 Lower Encoder Port**
Connects encoders to machine (upgrade required).
- 10 Upper Encoder Port**
Connects encoders to machine (upgrade required).
- 11 Accessory Ports**
For laser accessory.

Machine Throat Left

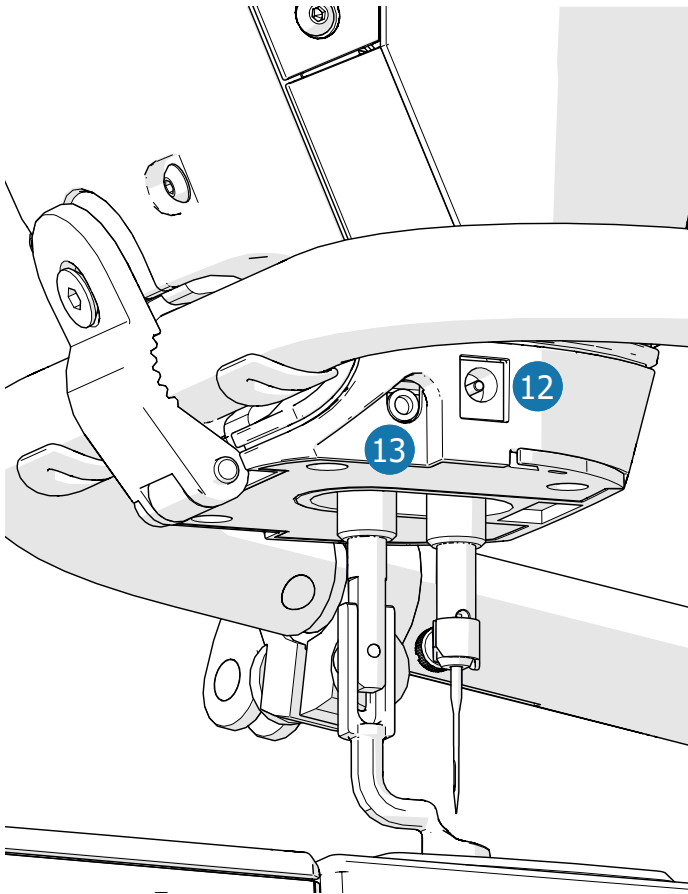

12 Left Accessory Port
For laser accessory.

13 Left Handlebar Port (page 13)
Connects handlebar controls to machine.

Machine Throat Right

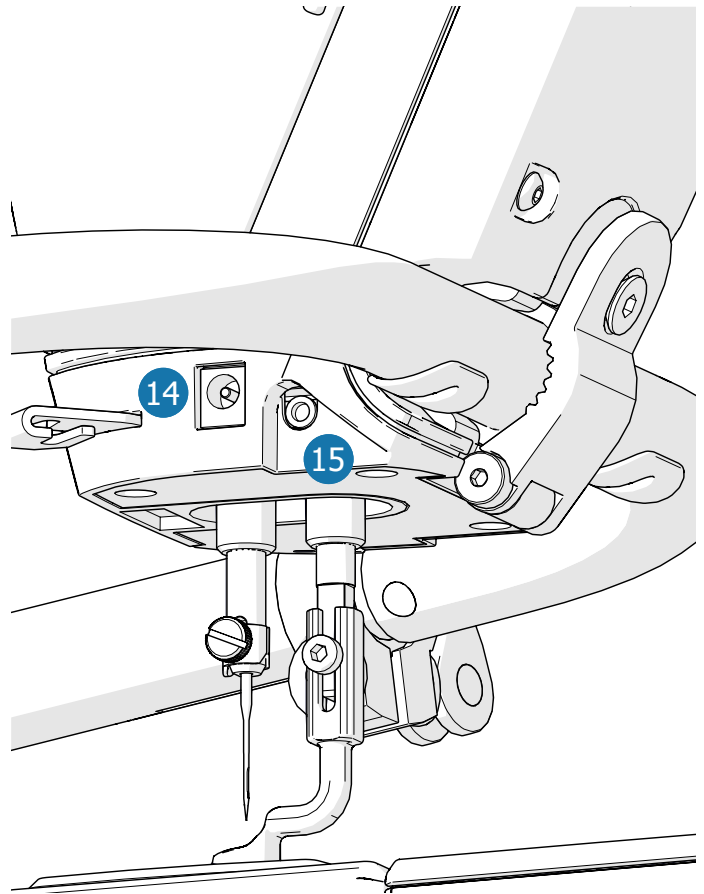

14 Right Accessory Port
For laser accessory.

15 Right Handlebar Port (page 13)
Connects handlebar controls to machine.

My Machine Details

Use this page to write down some information about your machine. This will be helpful if you ever need to call a Grace Company support technician.

Machine Type: Q'nique 16X Manual

Machine Serial Number: _____

Date of Purchase: _____

What Frame are You Using? _____

Select Which Machine Accessories You Have Purchased:

Q'nique 16X Upgrade

QuiltMotion

Back Handles

Q'nique Laser Stylus

Magnifique Magnifying Glass

Ruler Base

Quilt Perfect Ruler Feet Kit

360 Wonder Foot

4 Piece Accessory Hopping Foot

9 Piece Accessory Hopping Foot

Thread Spool Accessory

Find your serial number on the silver sticker on the back of the machine.

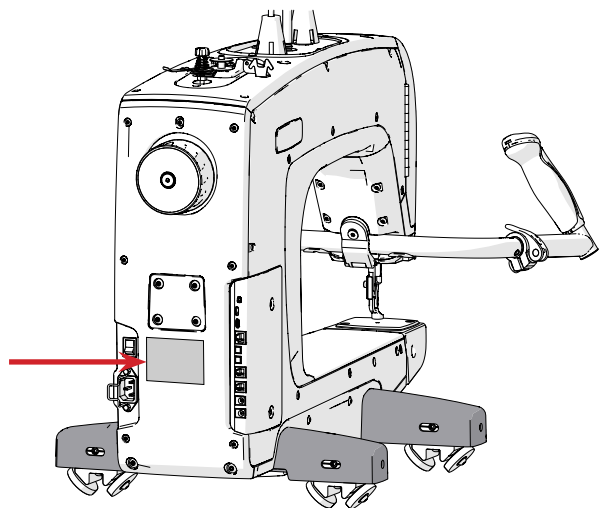

Included Parts and Tools

Level One (Workstation)

Tip: Parts are grouped together in the packaging for your convenience. For the best experience, do not remove parts from the packaging until instructed to do so.

Back Wheel Assembly

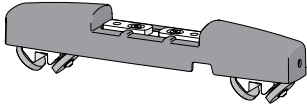

SMP-09-16244
See page 7

Front Wheel Assembly

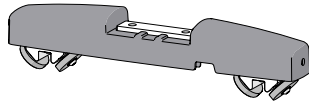

SMP-09-16239
See page 7

Tools Box

T-handle Allen Wrench 4 mm

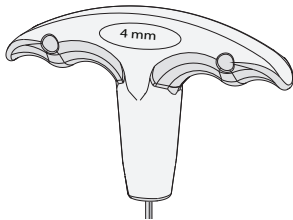

HDW-03-13114

T-handle Allen Wrench 3 mm

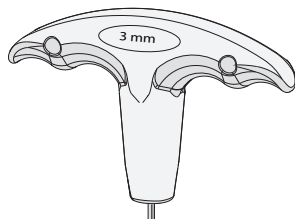

HDW-03-13115

T-handle Allen Wrench 2.5 mm

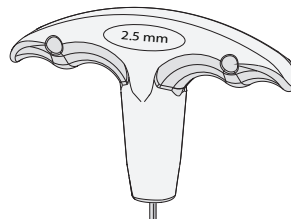

HDW-03-13116

T-handle Allen Wrench 2 mm

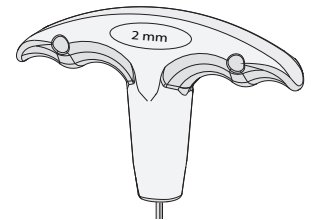

HDW-03-13117

Lint Brush

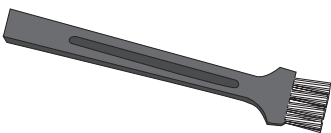

SMP-03-10170
See page 42

Needle Size 18
(one 10 pack)
(one pre-installed)

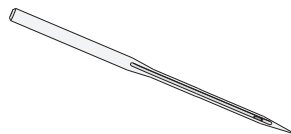

ACC-01-14517
See page 46

Needle Size 16
(one ten pack)

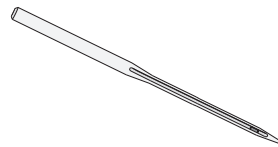

ACC-01-14516
See page 46

Needle Magnet

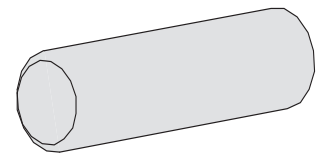

SMP-09-13837
See page 46

Included Parts and Tools (continued)

Flat-head Screwdriver

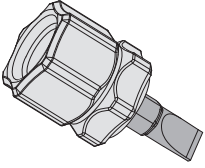

SMP-03-10169
See page 51

Hopping Foot Height tool

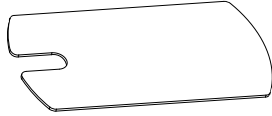

SMP-03-12171
See page 48

M Class Bobbin (x3) (Two pre-installed)

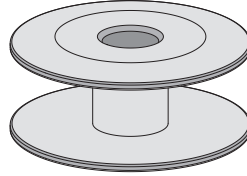

SMP-08-10070
See page 19

Timing Spacer Tool

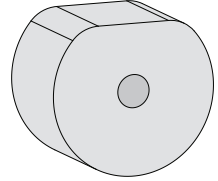

SMP-03-11320
See page 59

Wheel Base Hardware Box

SBHCS Screw M6 x 35 mm (x2)

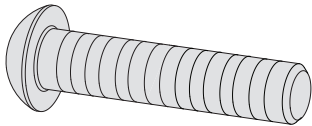

HDW-03-10738
See page 11

Shoulder Bolt M6 (x2)

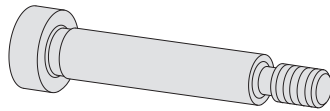

HDW-03-10541
See page 11

Washer M6 (x2)

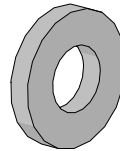

HDW-03-11557
See page 11

Thread Stand Hardware Box

SBHCS Screw M4 x 12 mm (x3)

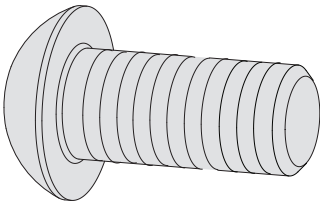

HDW-03-14247
See page 16

SBHCS Screw M4 x 20 mm (x1)

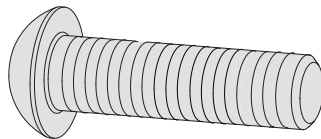

HDW-03-11661
See page 16

Power Cord/Oil Bottle Box

**Oil
Bottle**

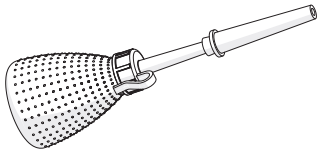

SMP-09-13888
See page 42

**Power
Cord**

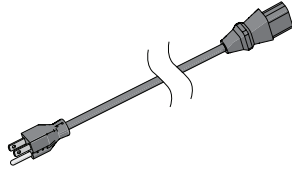

SMP-02-14466
See page 17

**M3 Thumb Screw
(needle bar spare)**

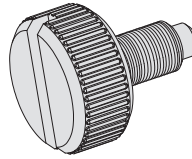

HDW-03-11736
See page 46

**Hopping Foot
Screw**

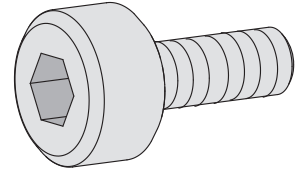

HDW-03-10966
See page 48

Level Two

**Handlebar
Assembly**

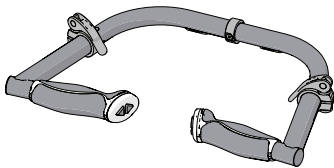

SMP-09-14066
See page 13

**Thread Stand
Assembly**

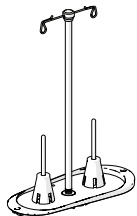

SMP-09-16235
See page 16

Sample Thread Kit

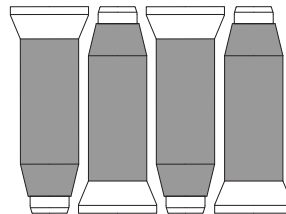

MIS-11-16122

Welcome to Your Q'nique 16X Manual

We are pleased to introduce you to the newest part of your quilting setup. This machine has been especially designed to help quilters like you have the tools available to create quality projects.

This manual is broken into four sections (or parts). Notifications at the end of each section will direct you to switch to your frame manual or QuiltMotion manual for instructions on assembling those products. This creates a streamlined process of building a complete quilting setup in the most efficient way. Use the following flowchart to guide you in navigating multiple manuals. If you are not using one of the products in the flowchart, just move to the next item in the chart.

Thank you again for choosing us to help with your quilting projects.

- The Grace Company

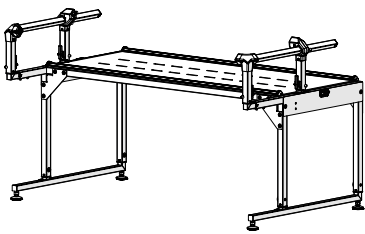

Start Here: Frame Manual: Part One

- Assemble the frame's legs, table, and sides.
- Install the channel lock onto the bottom carriage.
- Align your tracks.

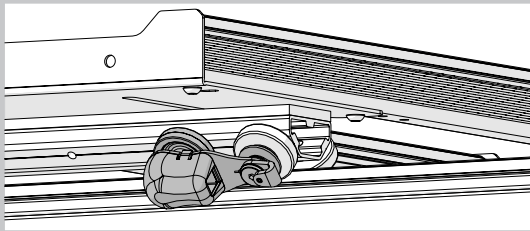

Quilting Machine Manual: Part One

- Install the lower encoder onto the bottom carriage.

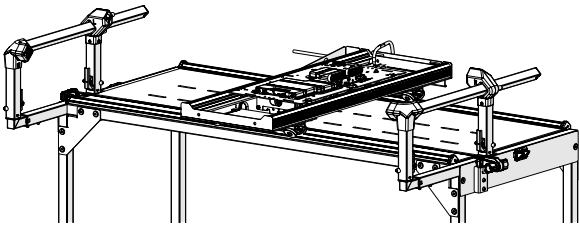

QuiltMotion Manual: Part One

- Prepare the bottom carriage.
- Install the long belt across the frame.

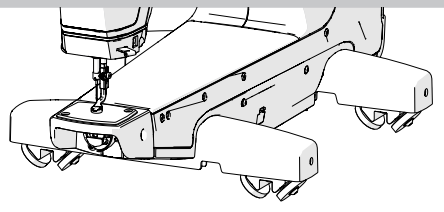

Quilting Machine Manual: Part Two

- Install your machine's wheels.
- Align your wheels.

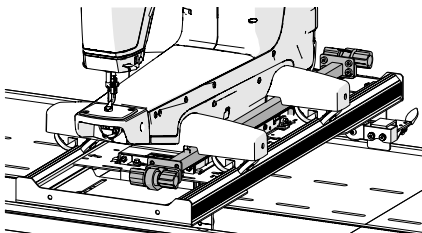

QuiltMotion Manual: Part Two

- Install the short belt.
- Tension the short belt.

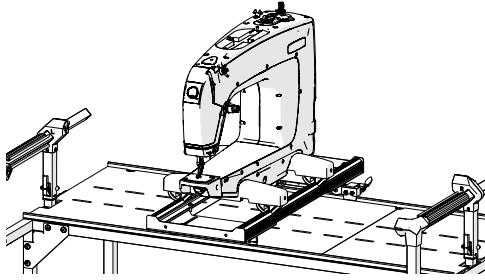

Frame Manual: Part Two

- Install the channel lock on the machine or top plate.
- Prepare the top plate and home sewing machine.
- Place the machine or top plate on the frame.

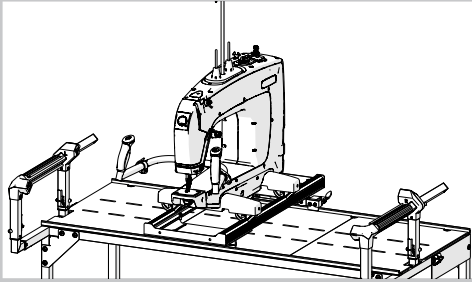

Quilting Machine Manual: Part Three

- Install the handles and the thread mast.

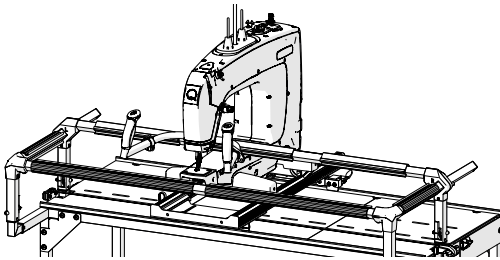

Frame Manual: Part Three

- Install the rails and fabric bungees.
- Position and adjust the rails.
- Adjust the carriage stop.
- Level the frame.

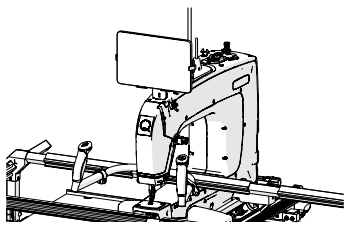

QuiltMotion Manual: Part Three

- Install the tablet bracket.
- Plug in QuiltMotion.

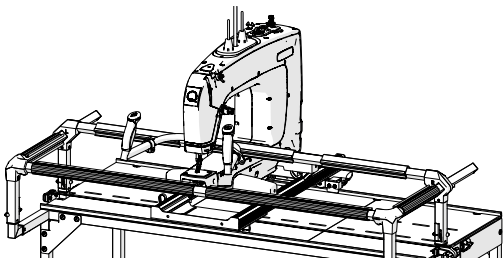

Frame Manual: Part Four

- Install the velcro tape
- Install the cloth leaders
- Attach the fabric

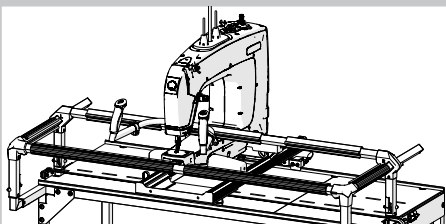

Quilting Machine Manual: Part Four

- Use the quilting modes and settings in the display.
- Maintain the machine and perform repairs.

Animated Instructions

To provide the best possible customer experience, we also offer animated video instructions for setting up this product. To view the animated instructions, visit our website at:

<https://l.ead.me/16xmanualstart>.

You can also use your smartphone to scan this QR code:



Out-of-the Box Assembly

This section of the manual covers all the steps to assemble the machine after you bring it home for the first time.

Task 2 - Installing the Wheels	page 7
Task 3 - Installing the Handlebars	page 13
Task 4 - Attaching the Thread Stand	page 16
Task 5 - Turning the Machine On/Off	page 17

Part One

Before completing the tasks in Part One of your machine instructions, please complete Part One of your frame instructions.

Progress Checkpoint:

Have you:

- Assembled your frame's legs and table?
- Installed and align the frame tracks?
- Installed the channel lock on the bottom carriage?
- Installed the rail supports?

Note: Do not install the rails at this time.

If you've already fully assembled your frame, uninstall your frame's take-up rail.

Task 1 - Prepare Frame for the Machine

Parts & Tools Needed:

- **Microfiber or Damp Cloth**

Instructions

Take the following steps to prepare your frame and bottom carriage for your machine:

- 1 Take a damp cloth, or a microfiber cloth, and wipe down the tracks on your frame and bottom carriage. Make sure the frame is clear of foam or other pieces of packaging that may have stuck to your frame.

Congratulations! You have completed Part One of this manual.

If you are also installing QuiltMotion, complete Part One of your QuiltMotion manual.

If you are not installing QuiltMotion at this time, continue to Part Two of this manual on page 6.

Part Two

Before completing the tasks in Part Two of your machine instructions, please complete Part One of your QuiltMotion instructions if you will be installing automation today.

Progress Checkpoint:

QuiltMotion Manual Part One (optional)

Have you:

- Installed the motor plate into your bottom carriage?
- Installed the long belt onto your frame?

Task 2 - Installing the Wheels

Parts & Tools Needed:

Back Wheel Assembly

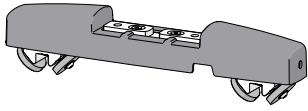

Packaging Level One

Front Wheel Assembly

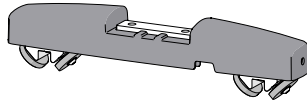

Packaging Level One

**SBHCS Screw
M6 x 35 mm (x2)**

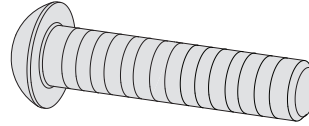

Wheel Install
Hardware Box

**Shoulder Bolt
M6 (x2)**

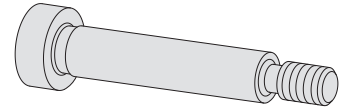

Wheel Install
Hardware Box

Washer M6 (x2)

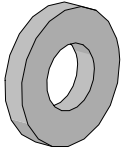

Wheel Install
Hardware Box

**T-handle Allen
Wrench 4 mm**

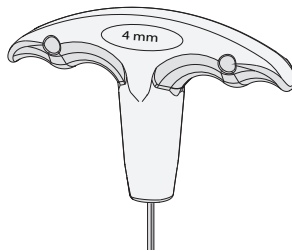

Instructions

Take the following steps to install the wheels on the bottom of the machine:

- 1 Remove the **front and back wheel assemblies**, the **tools box**, the **wheel install hardware box**, the **power cord/oil bottle box**, and the **thread stand hardware box** from the top layer of packaging. Set them aside.

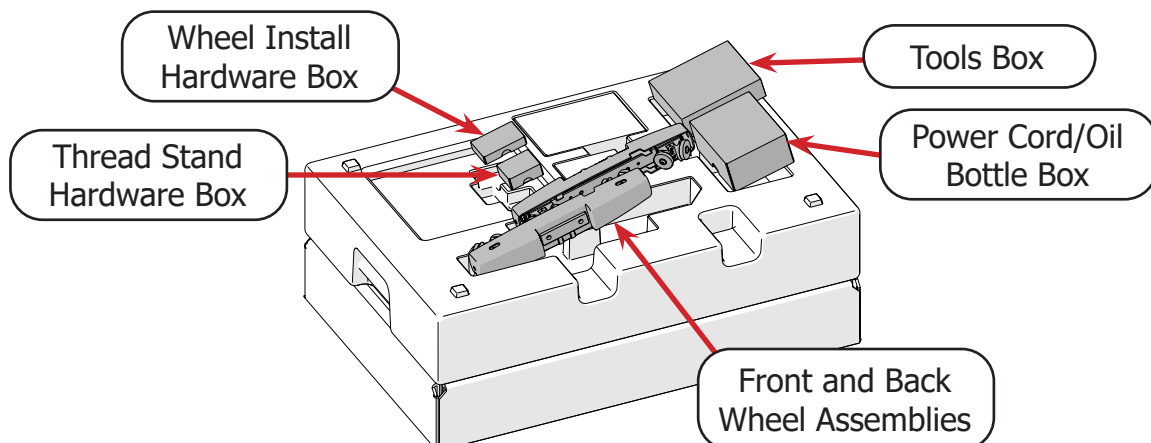

Task 2 - Installing the Wheels (continued)

- 2 Lift the top layer of packaging and place it beside the bottom layer that holds the machine.

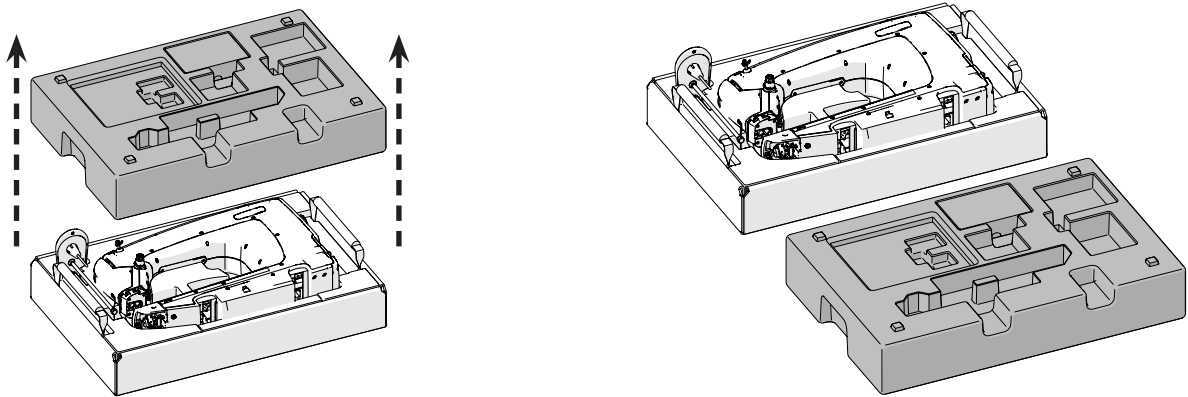

- 3 Use the **handles** to lift the bottom layer of packaging out of the box. Make sure to place it on top of the first layer of packaging so that the following items are lined up correctly:

- The bottom of the machine is over the **cutouts** in the side of the first layer of foam
- The holes in the bottom corners line up with the **tabs** on the top of the first layer of foam

Note: To avoid risk of injury to yourself or damage to the machine, it is highly recommended that this step be completed with two people, one lifting each side of the second layer of packaging.

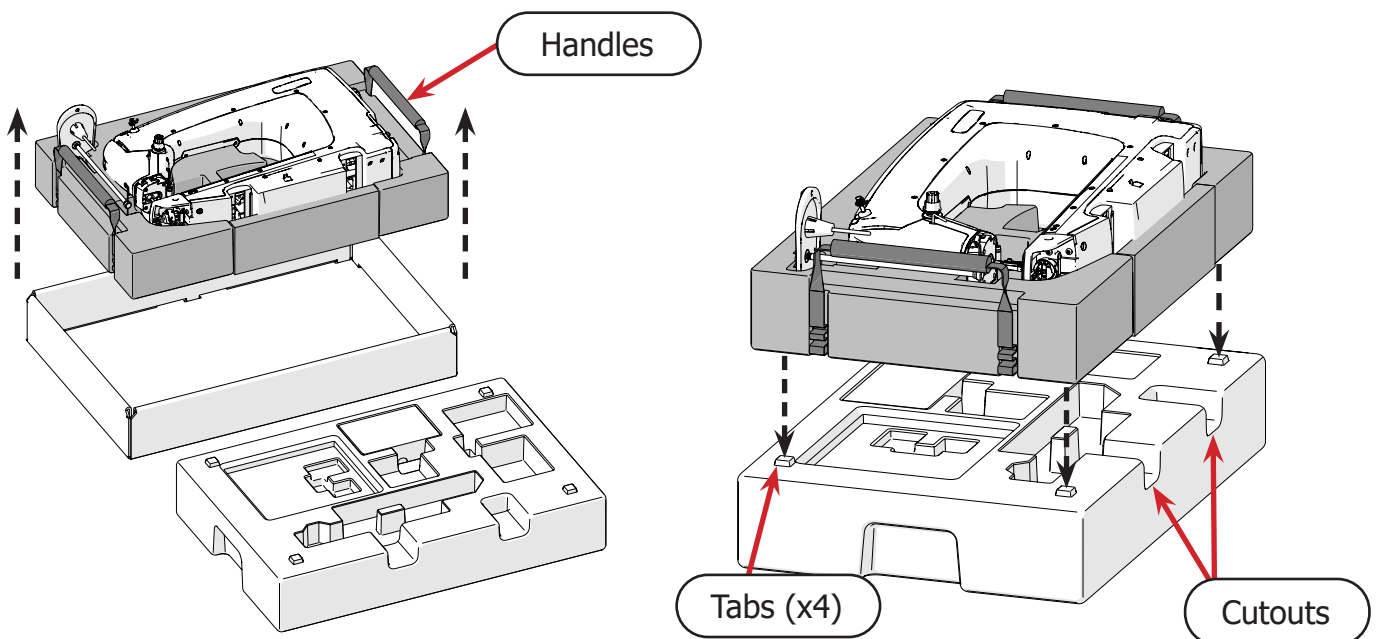

Task 2 - Installing the Wheels (continued)

4 Remove the piece of **foam** covering the bottom of the machine.

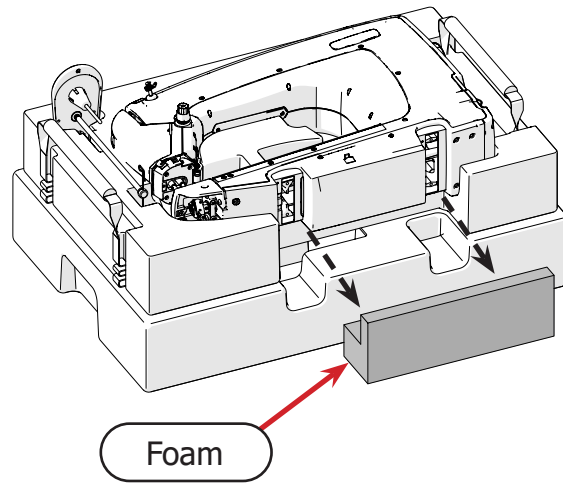

5 Identify which wheel assembly is for the front and which is for the back.

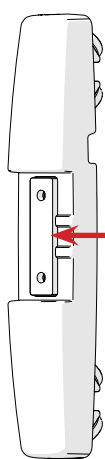

- Front Wheel Assembly:
- No visible screws on top
 - One rubber spacer

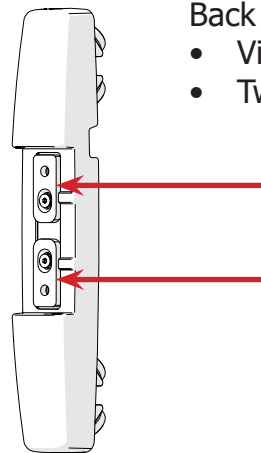

- Back Wheel Assembly:
- Visible screws on top
 - Two metal spacers

6 Attach the front wheel assembly to the bottom of the machine with the two **M6 shoulder bolts**, the two **M6 washers**, and the 4 mm Allen wrench. Make sure the **holes** in the back of the wheel assembly are facing towards the back.

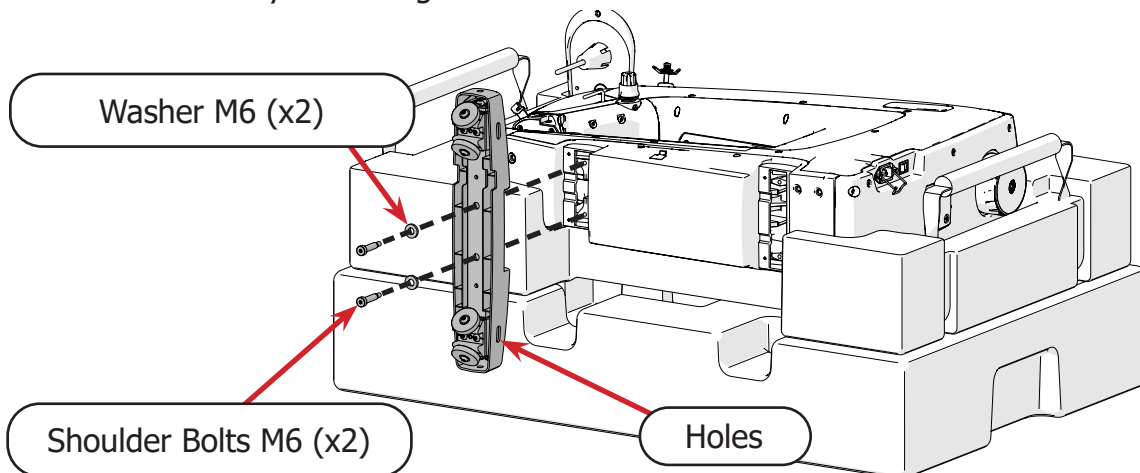

Task 2 - Installing the Wheels (continued)

- 7 Attach the back wheel assembly to the bottom of the machine with the two **M6 x 35 SBHCS** and the 4 mm Allen wrench. Make sure the **holes** in the back of the wheel assembly are facing towards the back.

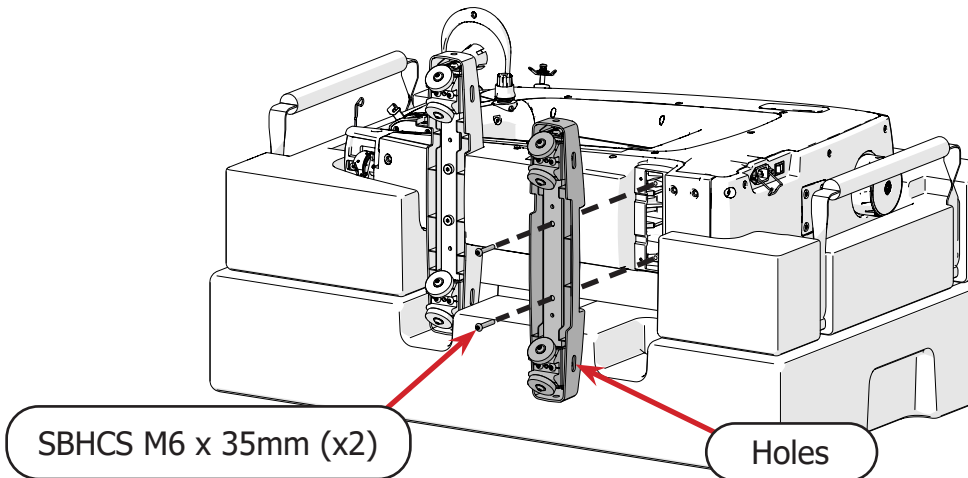

- 8 Remove the machine from the packaging and place it on the bottom carriage on the frame.

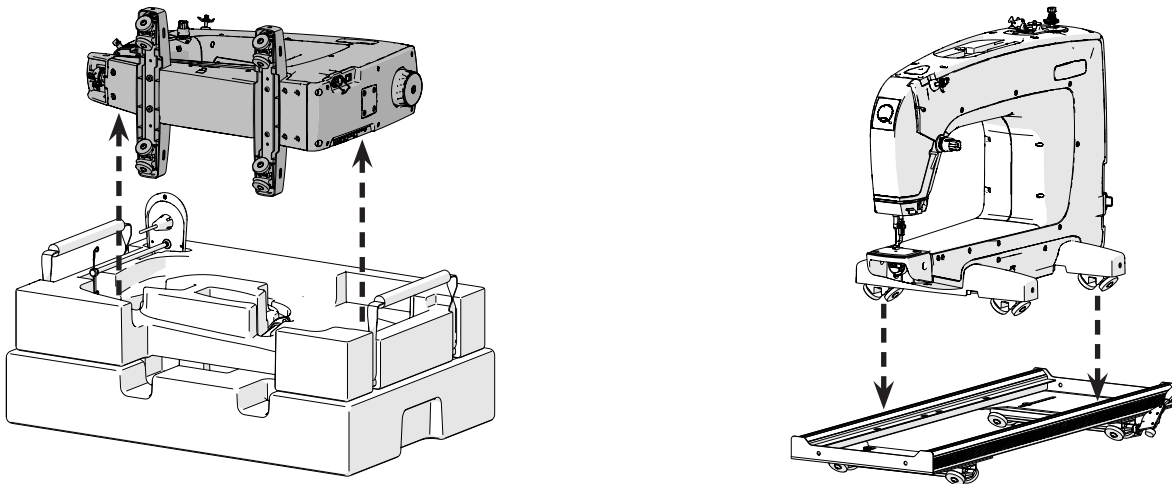

- 9 Use the 4 mm Allen wrench to loosen the **set screws** on one side of each of the wheel assemblies.

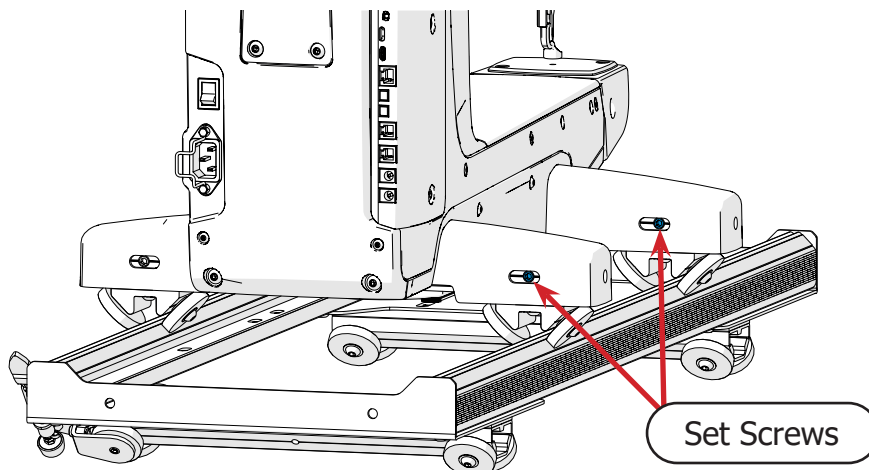

Task 2 - Installing the Wheels (continued)

- 10 Roll the machine up and down the bottom carriage tracks several times so that the machine can settle and ride smoothly.

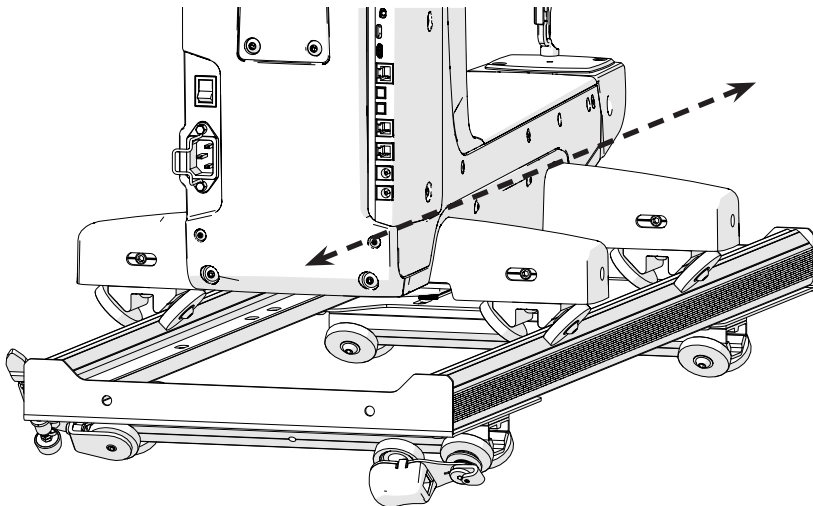

- 11 Use the 4 mm Allen wrench to re-tighten the wheel assembly **set screws** you loosened earlier.

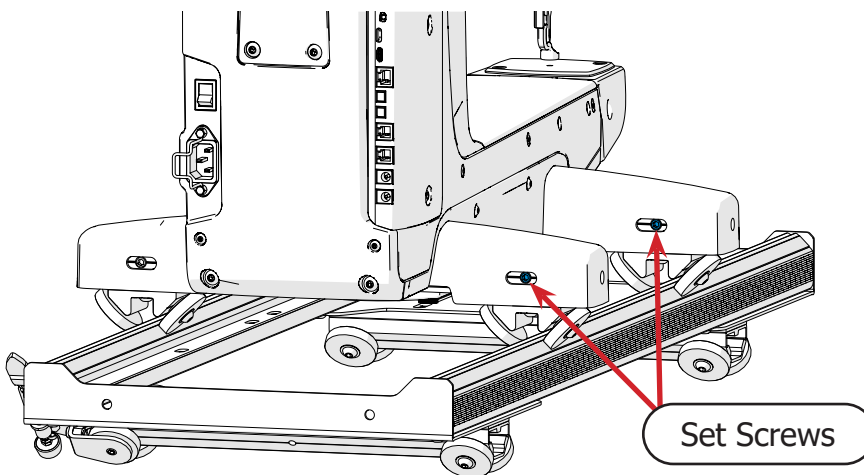

Congratulations! You have completed Part Two of this manual.

If you are also installing QuiltMotion, complete Part Two of your QuiltMotion manual.

If you are not installing QuiltMotion at this time but are assembling a new frame, continue to Part Two of your frame manual. If the frame manual is not broken in to parts, follow the manual's directions to:

- Install the channel lock onto your machine.

If you are installing your machine onto a frame that is already fully assembled, continue to Part Three of this manual on page 12.

Part Three

Before completing the tasks in Part Three of your machine instructions, please complete Part Two in your QuiltMotion manual (if setting up QuiltMotion at this time), and then part Two of your frame manual.

Progress Checkpoint:

Have you:

- Completed QuiltMotion Part Two (optional)?

Have you:

- Installed the channel lock onto the quilting machine?

If you've already fully assembled your frame:

- Install the channel lock onto the quilting machine.

Task 3 - Installing the Handlebars

Parts & Tools Needed:

Handlebar Assembly

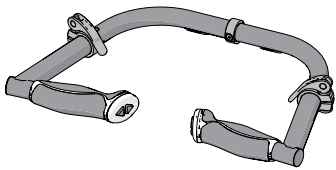

T-handle Allen Wrench 4 mm

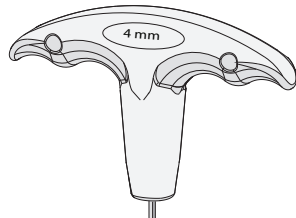

Instructions

Take the following steps to install and adjust the handlebars:

- 1 With the 4 mm T-handle Allen wrench, remove the **handlebar clamp screw** to open the handlebar clamp.

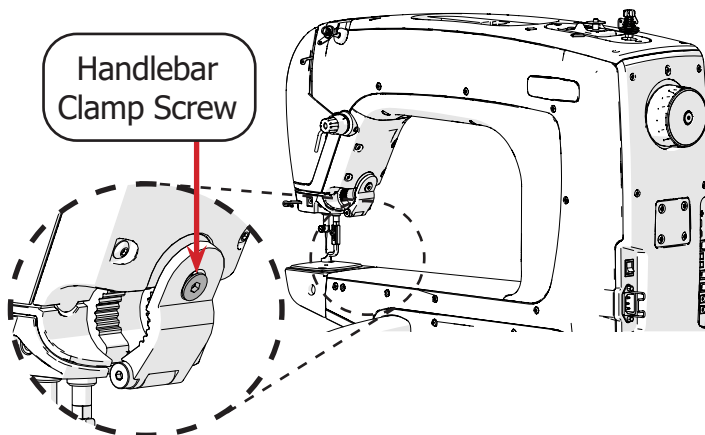

The handlebar clamp opens.

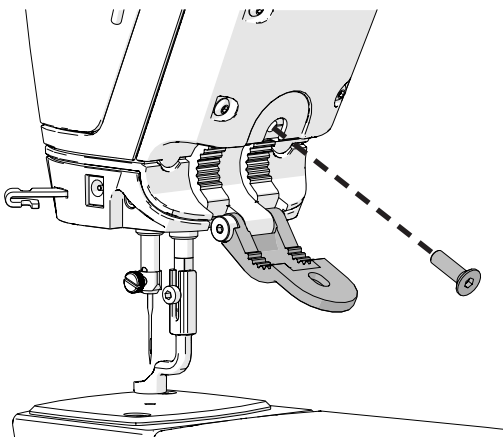

- 2 Take the **handlebar assembly** from the second level of the packaging.

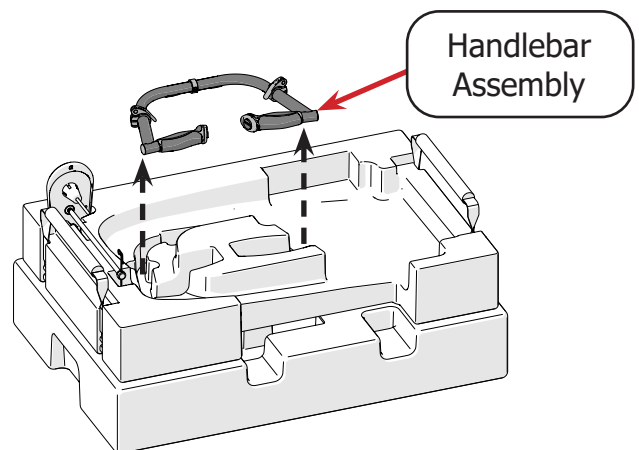

- 3 Slide them into the slot so that the **cables** are on the bottom.

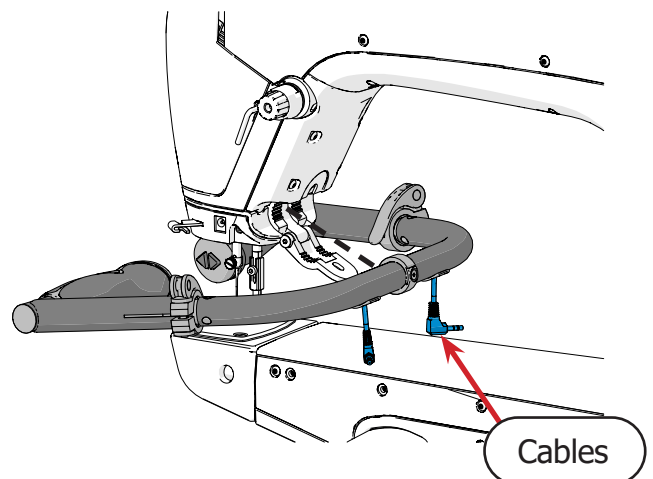

Task 3 - Installing the Handlebars (continued)

- 4 Close and hold the clamp, and loosely screw in the **clamp screw**.

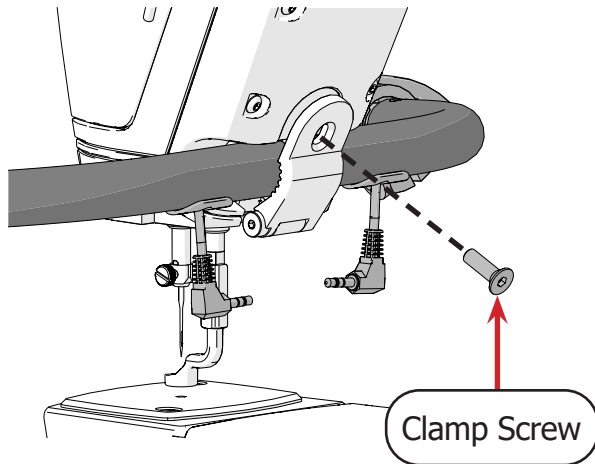

- 5 Hold the handlebars at the desired angle and tighten the clamp screw.

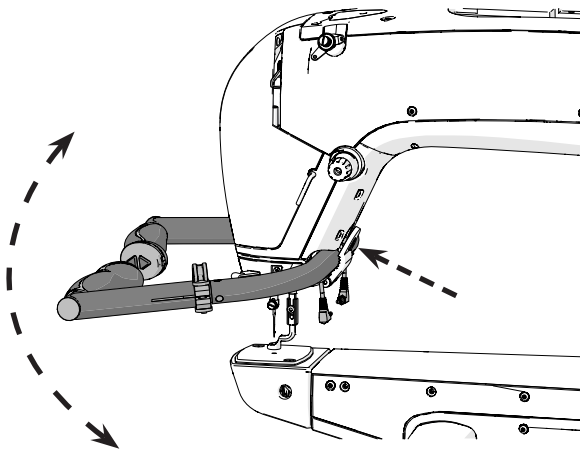

- 6 Open the **handlebar levers** (shown in blue).

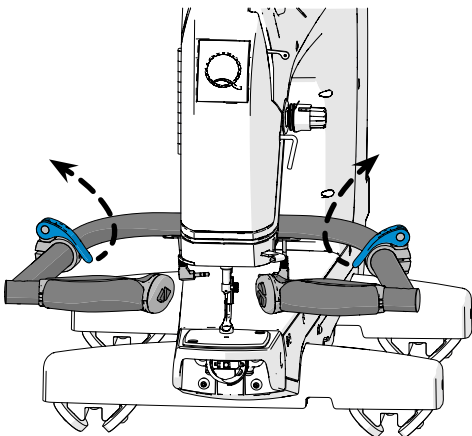

- 7 Twist the controls vertically until they are comfortable to hold and operate.

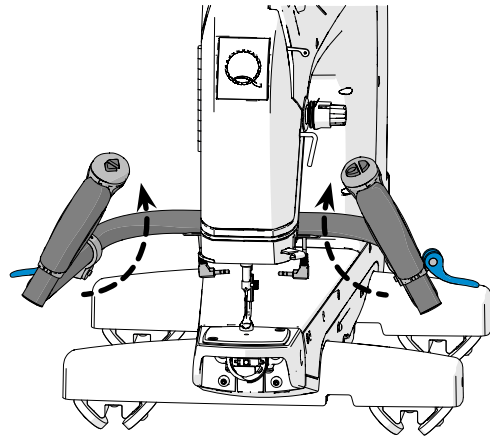

- 8 If desired, extend the handles outward to improve the reach of the machine.

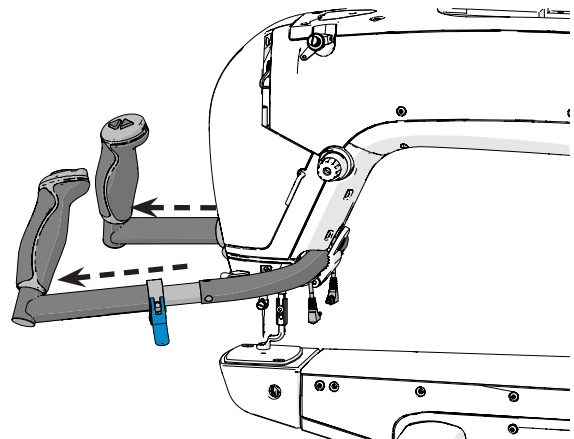

- 9 Once you are comfortable with the position of the handles, close the **handlebar levers**.

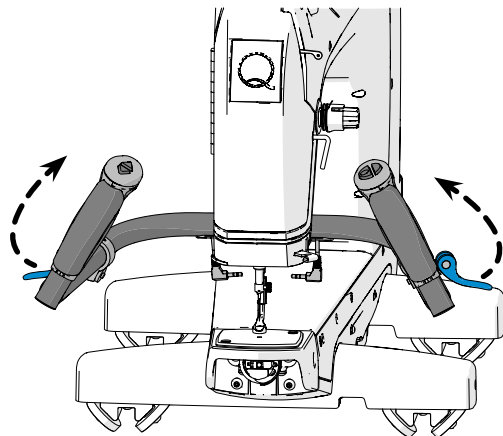

Task 3 - Installing the Handlebars (continued)

- 10 Plug the handlebar cables into the ports on both sides just above the hopping foot.

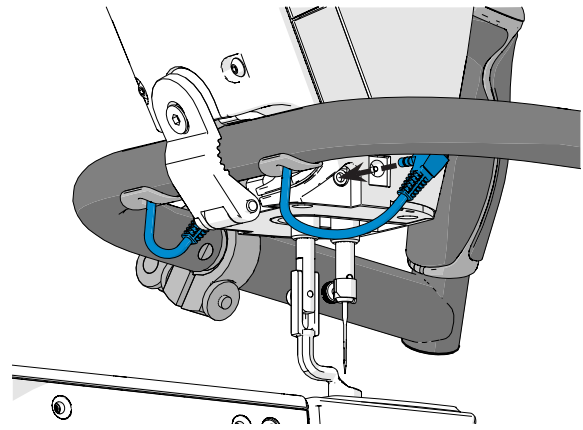
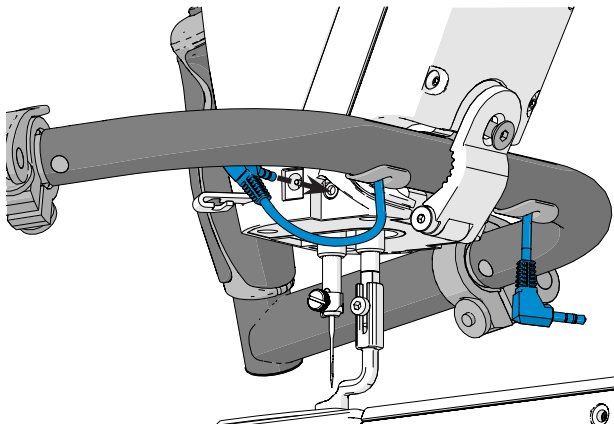

Task 4 - Attaching the Thread Stand

Parts & Tools Needed:

Thread Stand Assembly

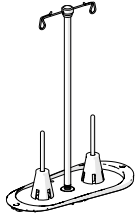

Packaging Level 2

SBHCS Screw M4 x 12 mm (x3)

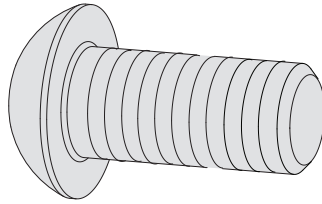

Thread Stand
HardwareBox

SBHCS Screw M4 x 20 mm (x1)

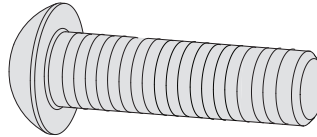

Thread Stand
HardwareBox

T-handle Allen Wrench 2.5 mm

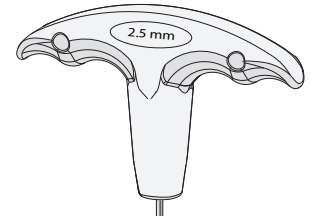

Instructions

Take the following steps to install the thread stand assembly:

1. Take the **thread stand assembly** out of the second level of packaging. The screws needed for this task are in the **thread stand hardware box** that you removed earlier.

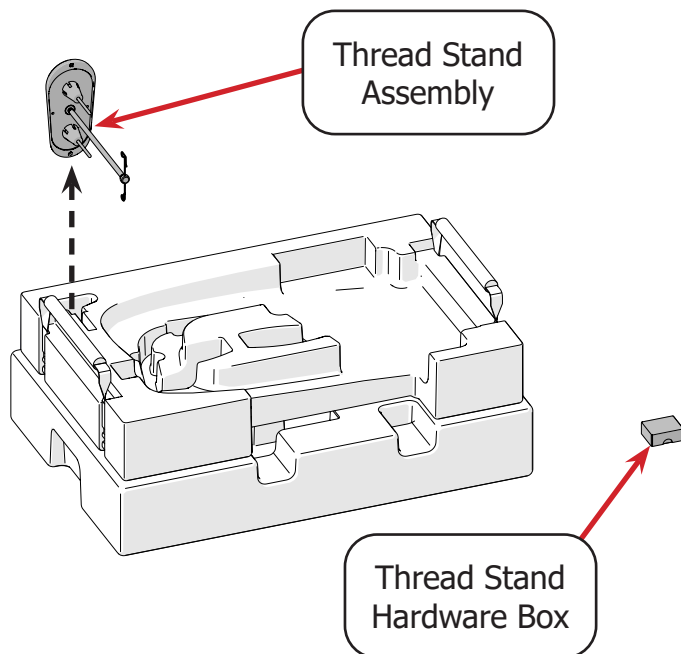

2. Secure the thread stand assembly in place using the 2.5 mm Allen wrench, three **M4 x 12 mm SBHCS**, and one **M4 x 20 mm SBHCS**.

The M4 x 20 mm SBHCS goes in the rear screw hole of the thread stand.

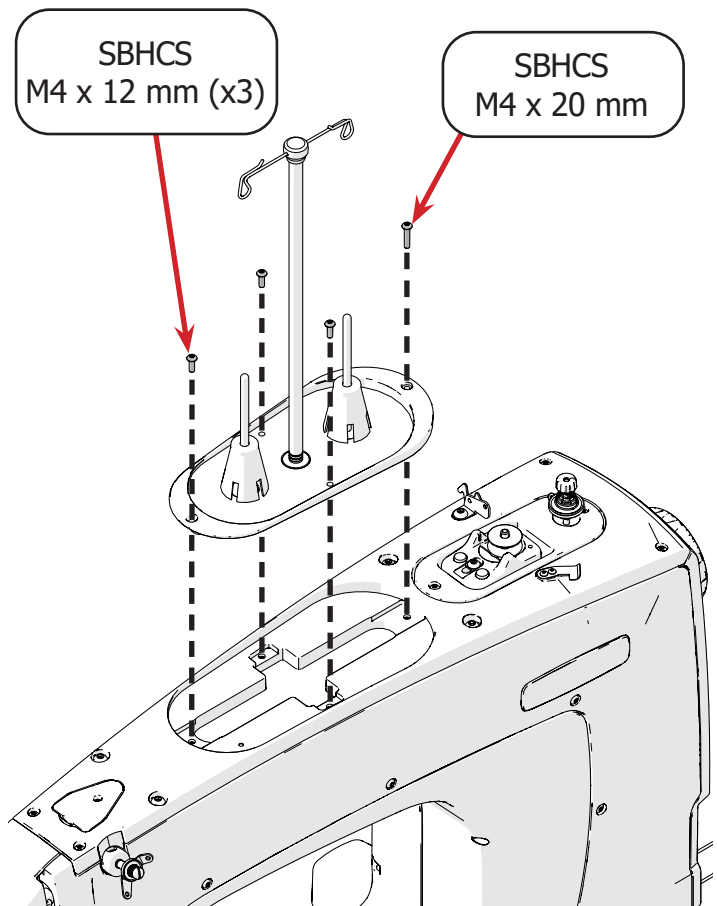

Task 5 - Turning the Machine On/Off

Parts & Tools Needed:

Power
Cord

Flat-head Screwdriver

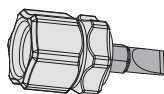
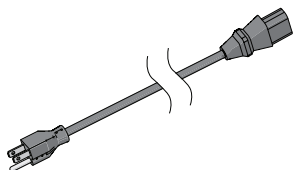

Instructions

The power cable port and power switch are located on the back of the machine. To power on the machine, take the following steps:

- 1 Find the power cord in the **power cord/oil bottle box** that you removed earlier.

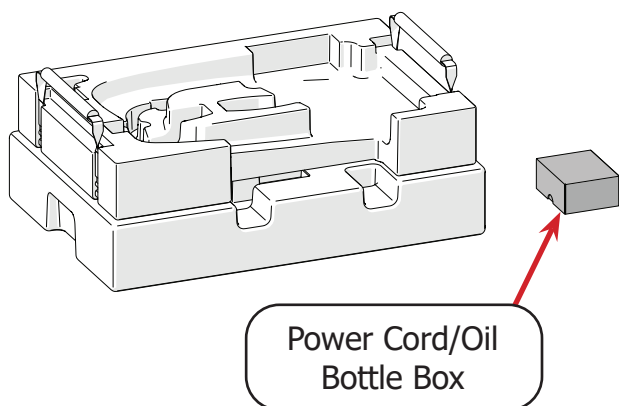

- 2 Move the **power cable retainer** (blue) to the side and plug the **power cord** into the back of the machine.

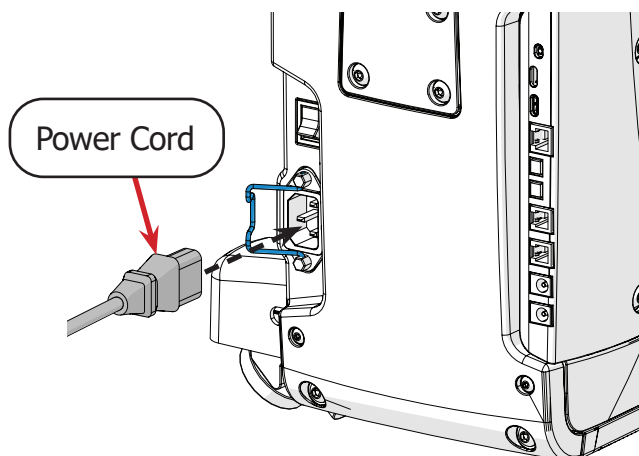

- 3 Press the **power cable retainer** (blue) firmly onto the power cable.

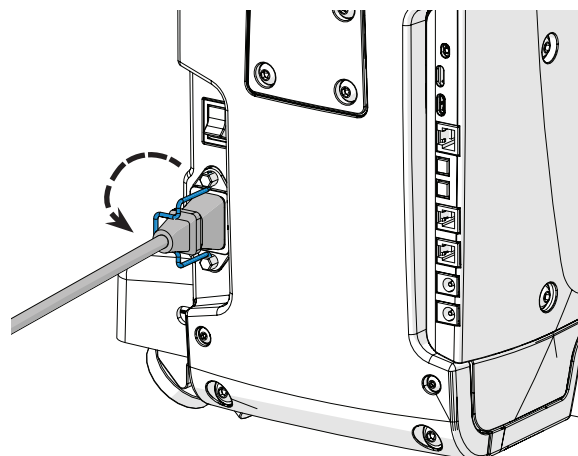

- 4 Press the **power switch** up to turn the machine on.

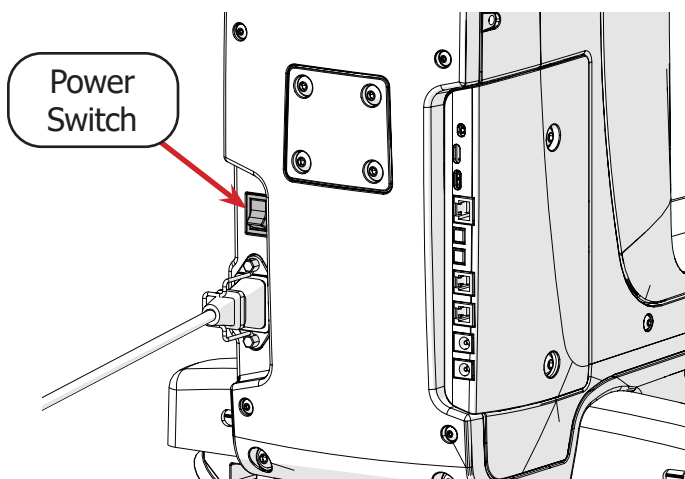

Preparing to Quilt

This section of the manual covers winding the bobbin, loading the bobbin case, and threading the machine.

Task 6 - Winding a Bobbin	page 19
Task 7 - Loading the Bobbin Case	page 22
Task 8 - Threading the Machine	page 24

Task 6 - Winding a Bobbin

Parts & Tools Needed:

Bobbin (Class M)

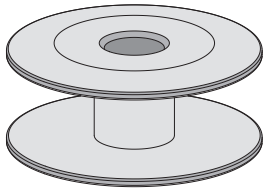

Tools Box

Instructions

Your machine comes with two bobbins pre-wound with 50 weight polyester Finesse thread. An empty M-class bobbin has also been provided. It's important to choose bobbin thread that is similar in type and quality as the top thread. For more information on choosing thread, see "Choosing Your Thread" on page 66.

Note: This machine uses cone-style thread. Unless you have the spool accessory, please use only thread cones for this machine.

The following diagram outlines the path the thread (shown in blue) must take to wind the bobbin.

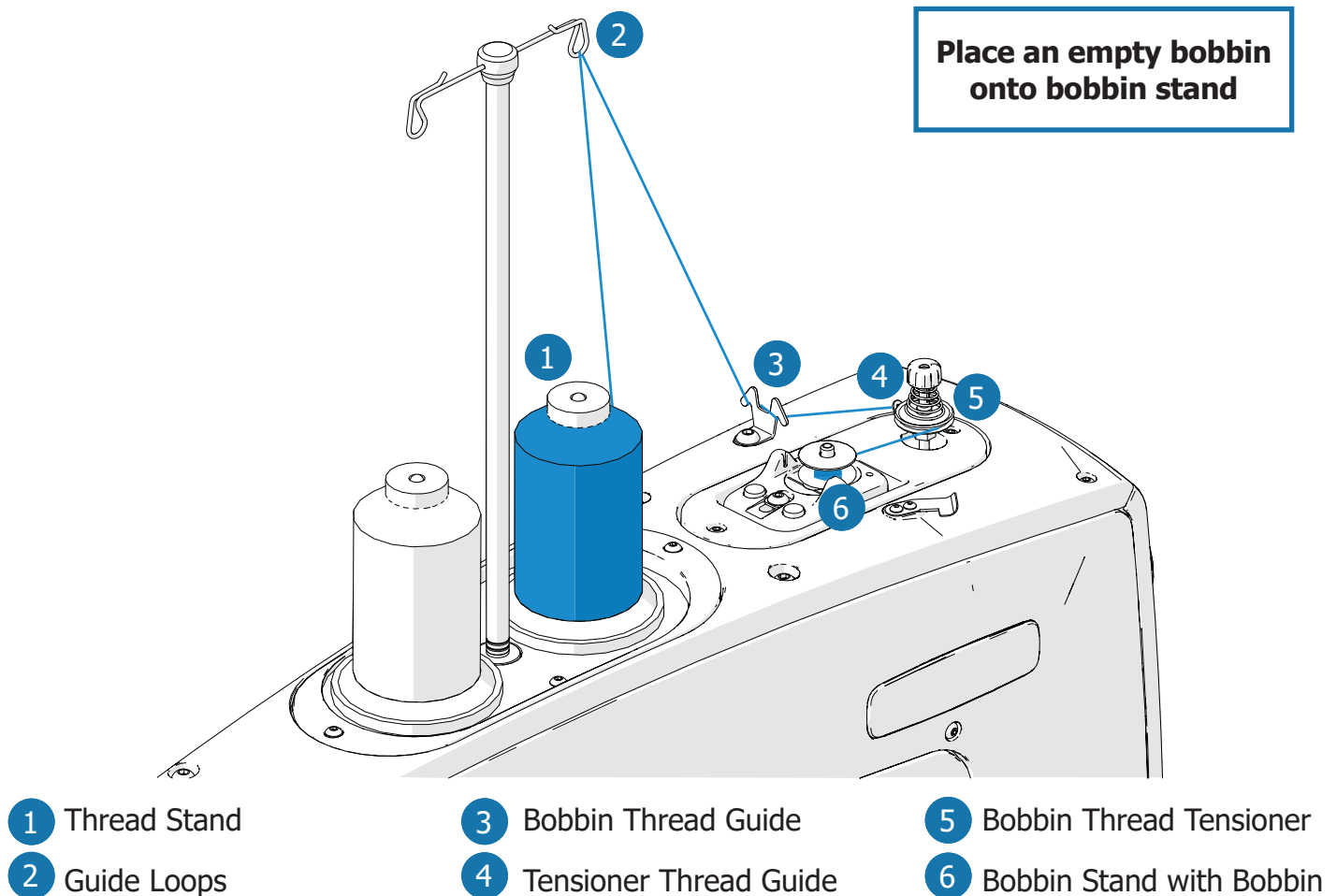

Task 6 - Winding a Bobbin (continued)

- 1 Run the thread through the **thread mast guide loop** directly above the thread cone.

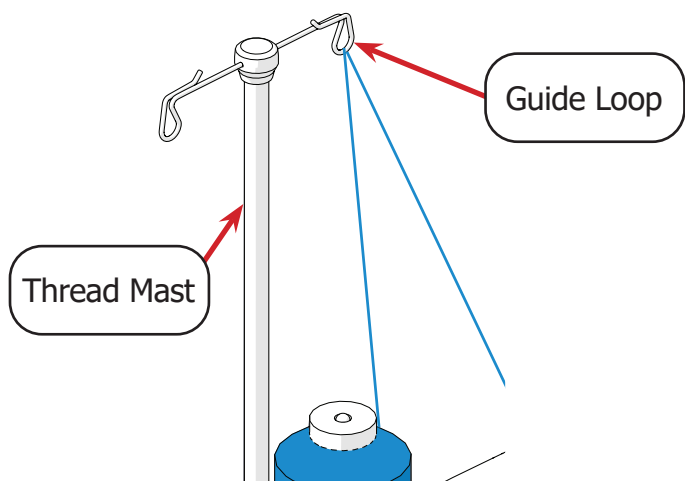

- 2 Pass the thread underneath the left wing of the **thread guide**. Then wrap the thread around the front of the right wing.

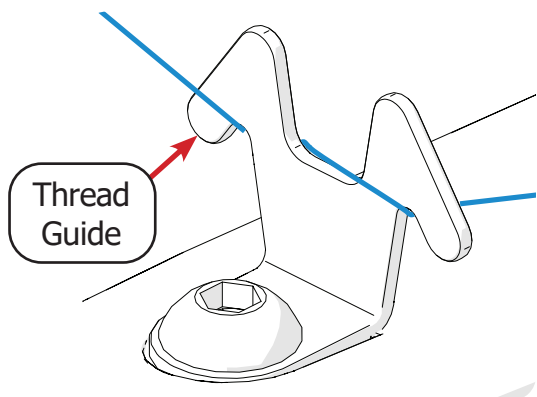

- 3 Pull the thread through the hole in the **tensioner thread guide** and then around the back of the **bobbin thread tensioner**, between the two discs.

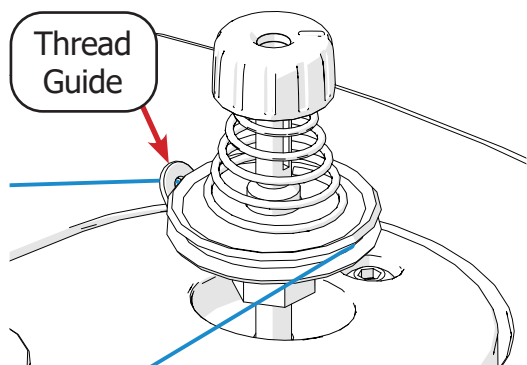

- 4 Wrap the thread clockwise around the empty bobbin. Press **start** when ready.

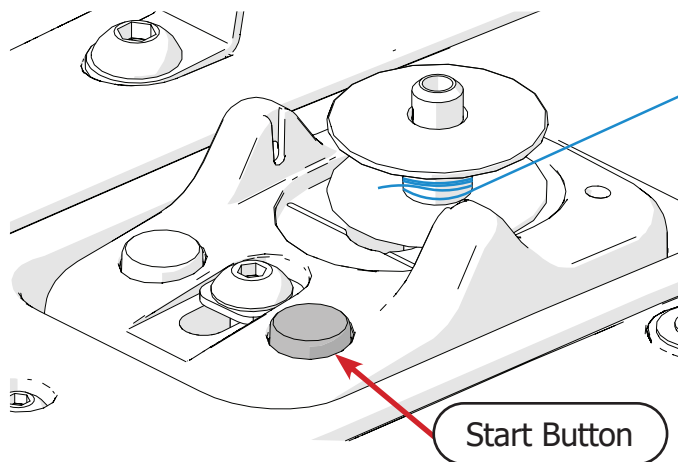

- 5 Winding stops automatically when the bobbin is full. Cut the bobbin away from the thread cone using the **thread cutter** near the bobbin winder.

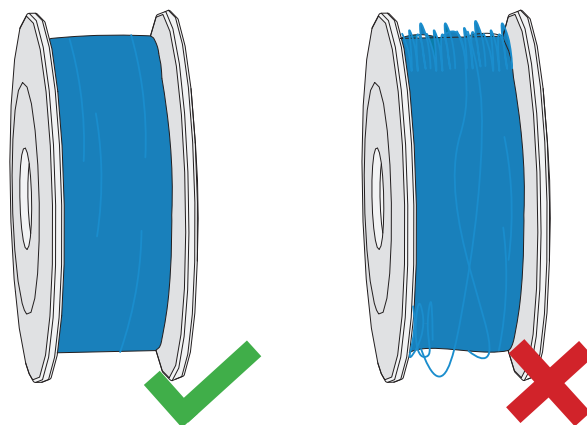
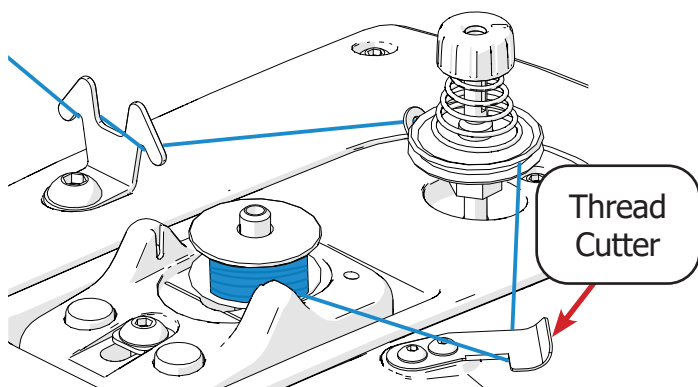

The bobbin thread should appear neat and smooth. See Bobbin Wind Troubleshooting Guide for more info.

Task 6 - Winding a Bobbin (continued)

Adjust Fill Levels

The bobbin winder can be adjusted to fill a bobbin to different levels if desired.

- 1 To adjust the bobbin winder, loosen the **M5 x 16 mm SBHCS** with the 3 mm Allen wrench.

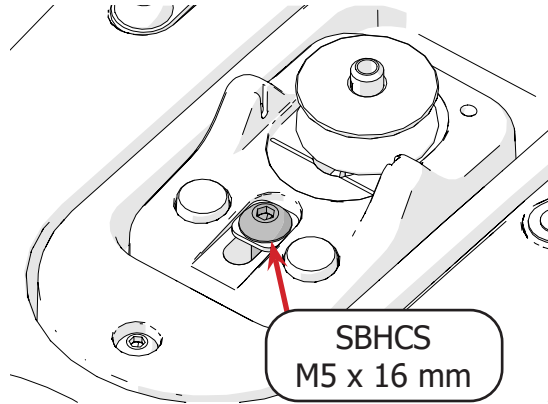

- 2 Slide the bobbin winder until the **guide line** underneath the bobbin is positioned where you want the bobbin thread to finish filling.

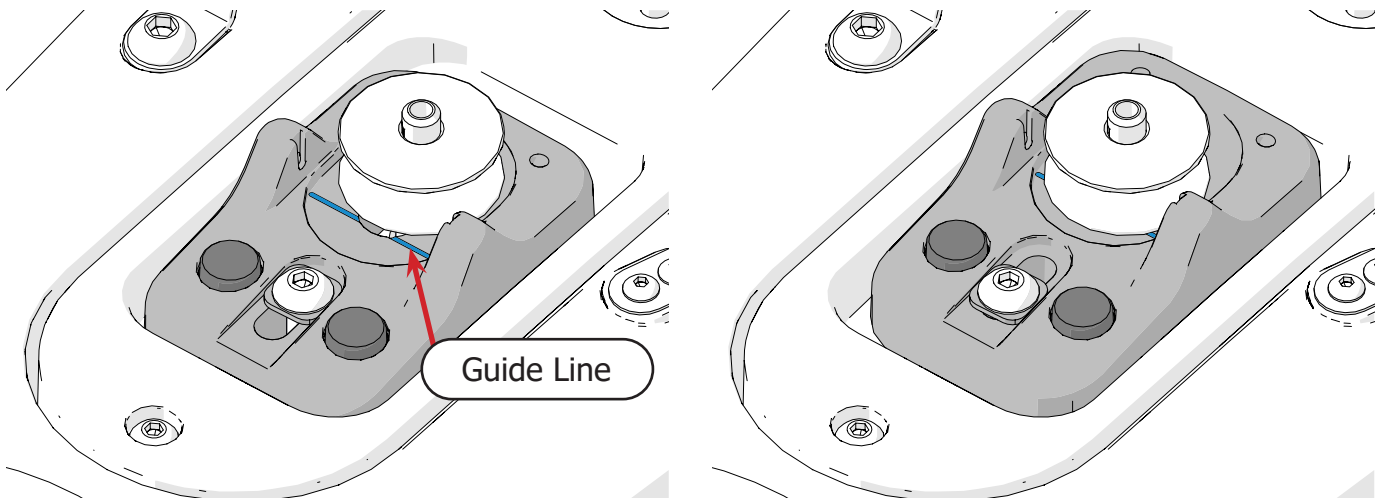

- 3 Tighten the M5 x 16 mm SBHCS to secure the bobbin winder in place.

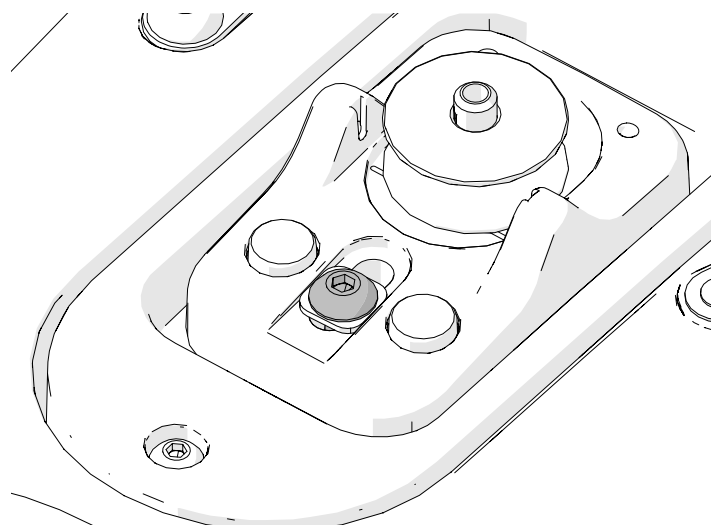

Task 7 - Loading the Bobbin Case

Take the following steps to insert the wound bobbin into the bobbin case and place it in the machine:

- 1 Check that the needle is up. If needed, rotate the **hand wheel** to raise the needle.

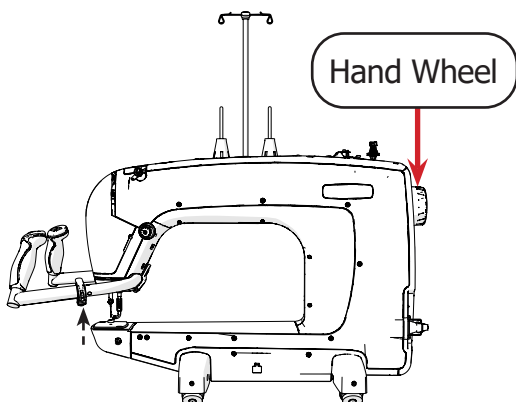

- 4 Place the wound bobbin into the **bobbin case**. Note the direction that the thread is coming off the bobbin in relation to the case.

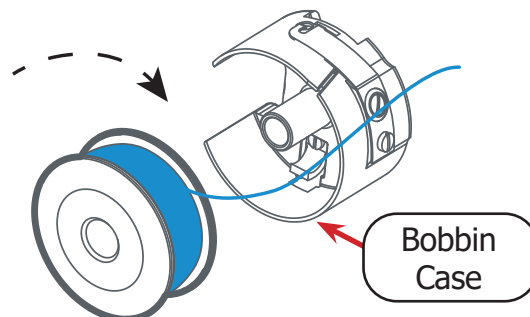

- 2 Press the **power switch** down to turn the machine off. This will prevent accidental stitching.

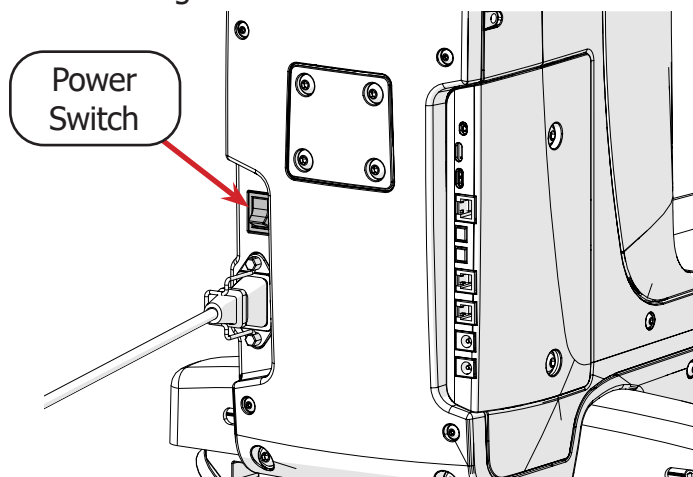

- 5 Slip a few inches of thread through the **slot** and out of the **hole**.

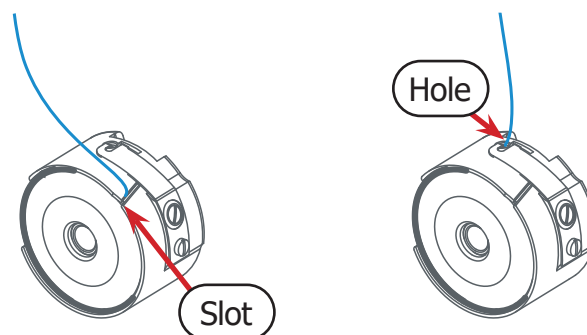

- 3 Pull on the bobbin case **release lever** to remove the bobbin case from the hook assembly.

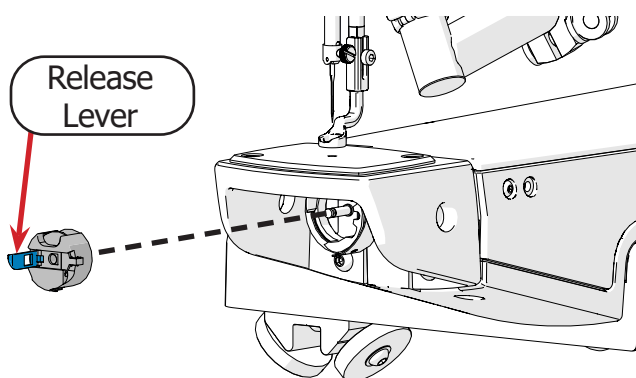

Note: If the bobbin is wound correctly it will turn clockwise when the thread is pulled.

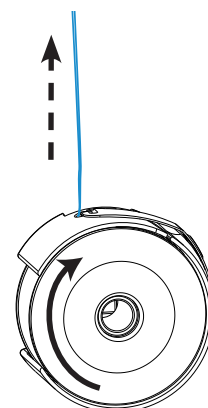

Task 7 - Loading the Bobbin Case (continued)

- 6 Test the tension of the bobbin case every time bobbin thread is changed; bobbin tension is the foundation for correct thread tension.

a. Place the bobbin case flat on its side, on your palm.

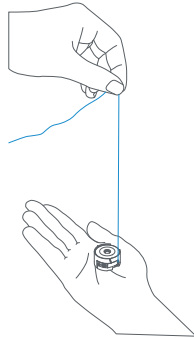

- b. Pull up on the thread. The thread should run freely and the bobbin case should rise into a vertical position without lifting off your hand.

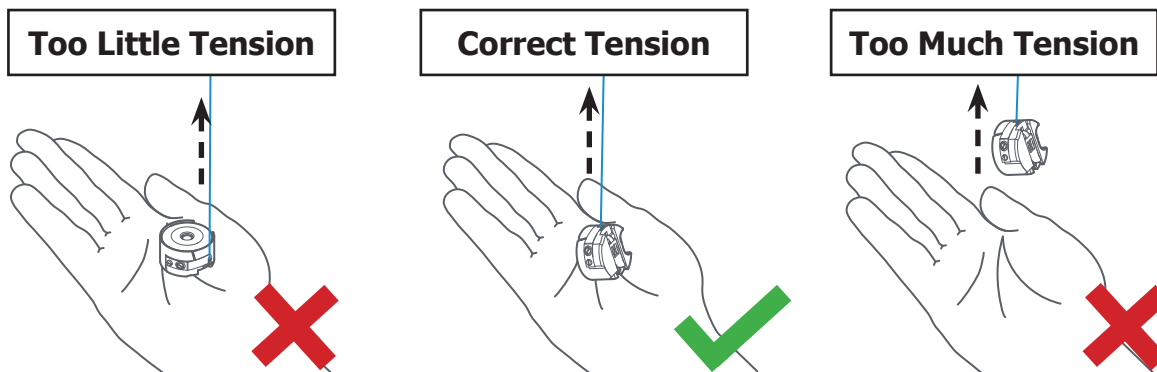

- If the case remains on its side, there is too little tension. Turn the **large screw** clockwise.
- If the case lifts into the air, there is too much tension. Turn the **large screw** counter-clockwise.

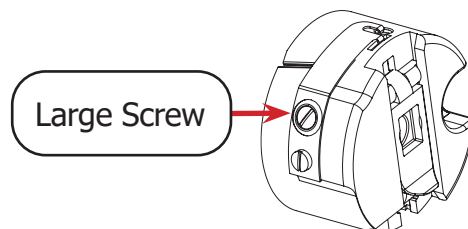

- 7 Place the bobbin case inside the machine with the **lever** (shown in blue) at the 3 o'clock position. It should click into place. Do not pull on the lever while inserting the bobbin case.

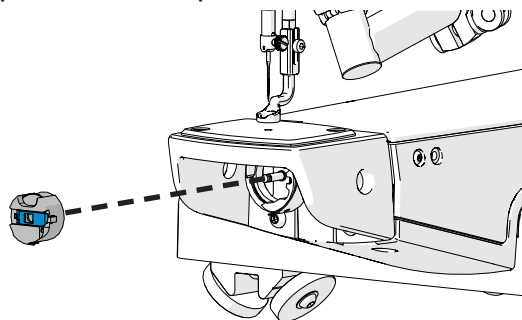

Task 8 - Threading the Machine

Before threading the machine, make sure you've selected quality thread for your project. Choosing the right thread for the machine can prevent the thread from breaking or tangling up under the needle plate. For more information on choosing thread, see page 66. Note the following:

- This machine uses cone-style thread, not thread from a spool. Do not use spool thread unless the spool accessory (not included in this kit) has been installed.



- Choose thread that is strong enough to pass the yank test (shown below), and re-test thread as it ages. Thread strength can diminish over time.

- Hold the cone in one hand and the end of thread in the other.

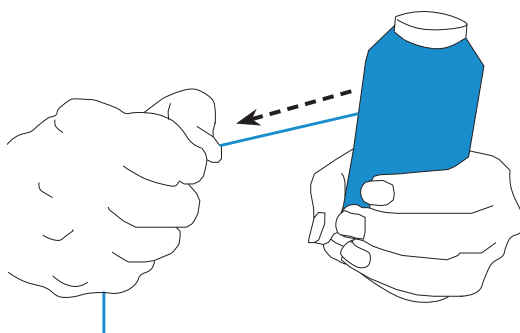

- Tug on the thread. If the thread snaps easily, it may be too brittle to use for quilting.

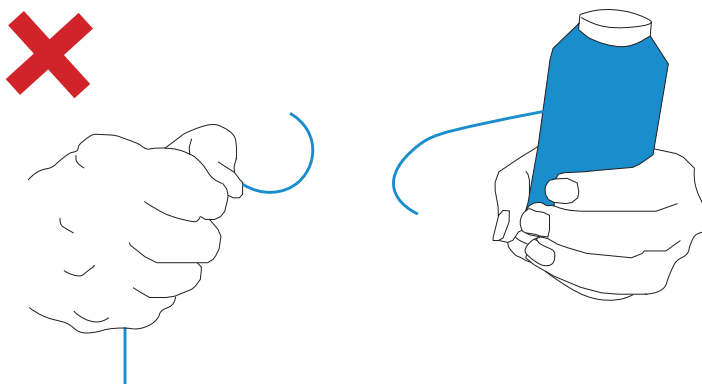

Task 8 - Threading the Machine (continued)

The following diagram outlines the path the thread (shown in blue) must take through the machine.

- 1 Thread Stand
- 2 Thread Mast Guide Loop
- 3 Small Thread Tensioner
- 4 Large Thread Tensioner
- 5 Check Spring
- 6 Thread Guide
- 7 Take-up Lever
- 8 Bottom Thread Guide
- 9 Needle Bar Eyelet
- 10 Eye of Needle

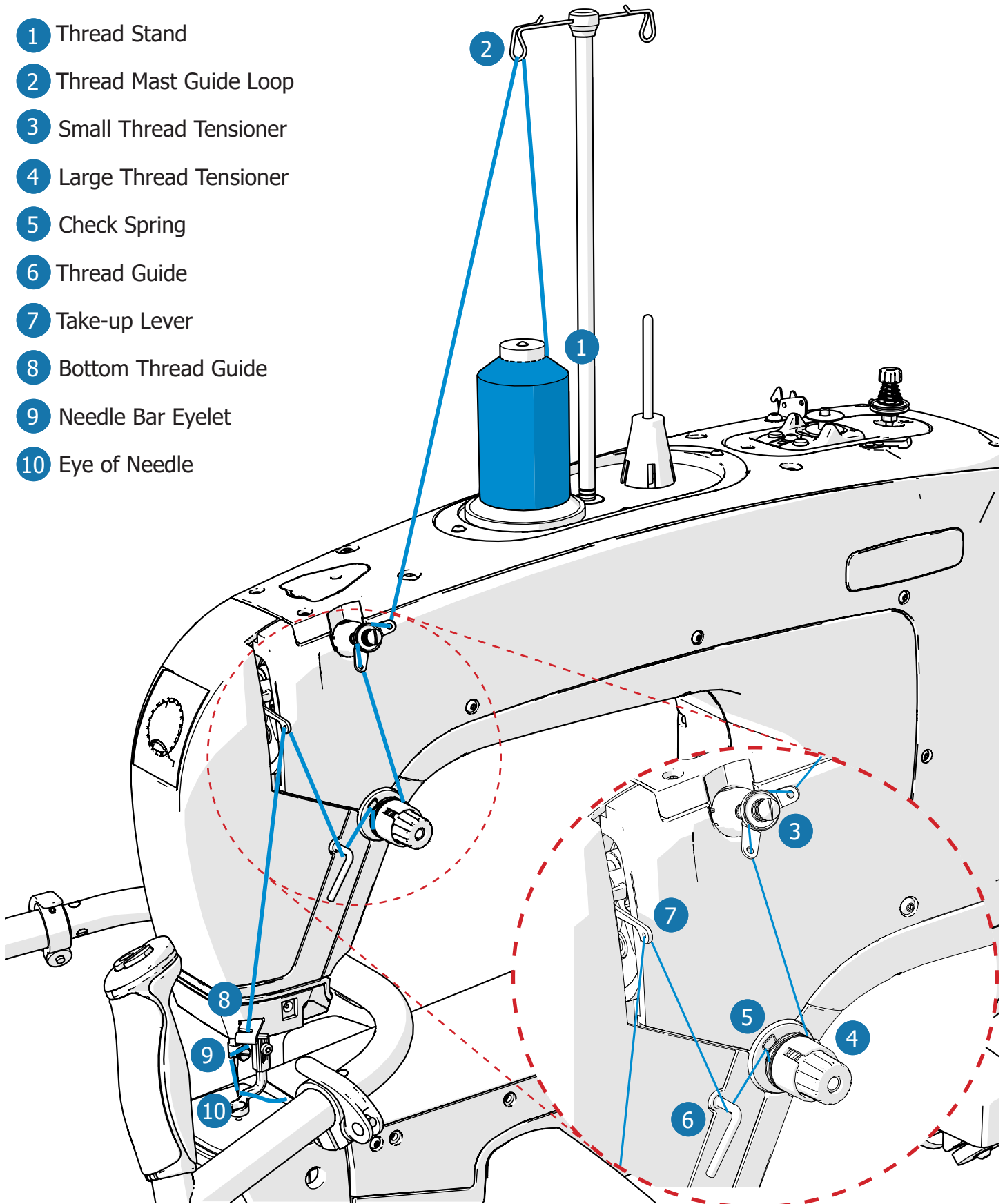

Task 8 - Threading the Machine (continued)

- 1 Rotate the **hand wheel** at the rear of the machine to raise the needle to the top position

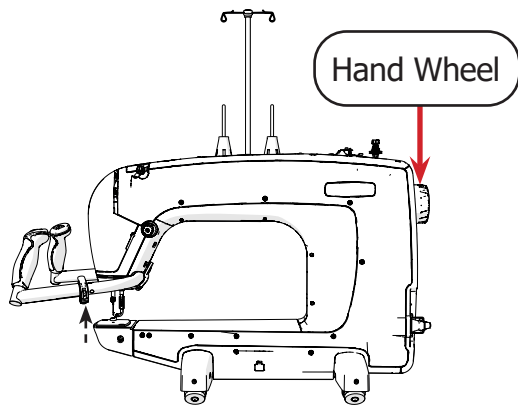

- 2 Press the **power switch** down to turn the machine off. This will prevent accidental stitching.

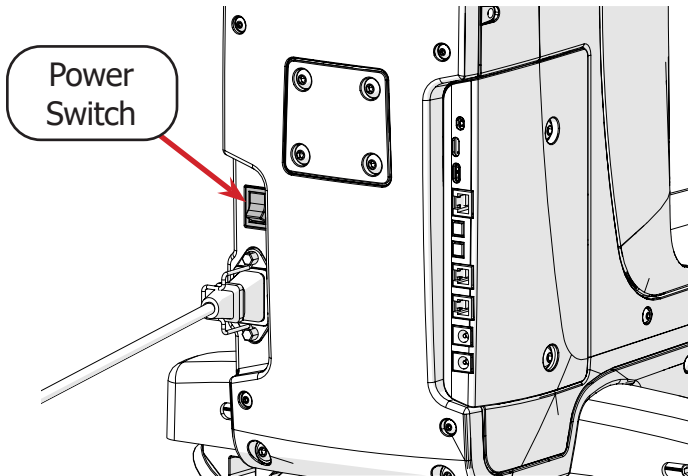

- 3 Place the thread cone on the cone-style **thread stand** toward the front of the machine.

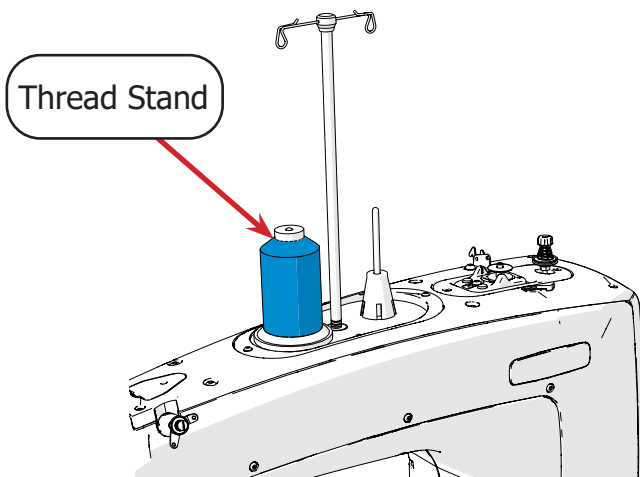

- 4 Pull the thread straight up, through the **thread mast guide loop** above the thread stand.

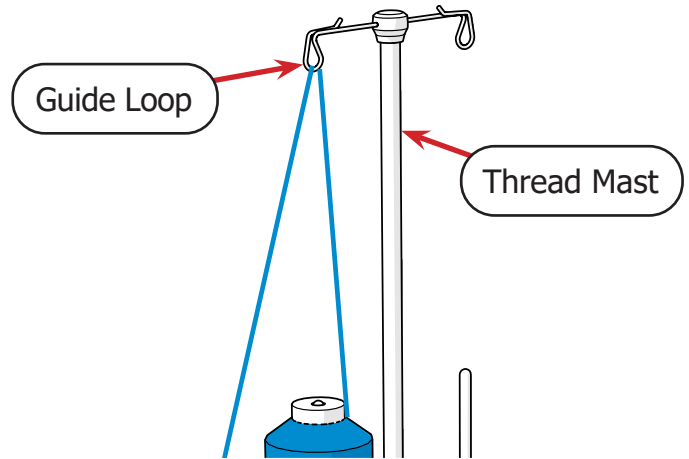

- 5 Run the thread through the top hole on the **small thread tensioner**. Then slip the thread between the two discs, and through the bottom hole of the small thread tensioner.

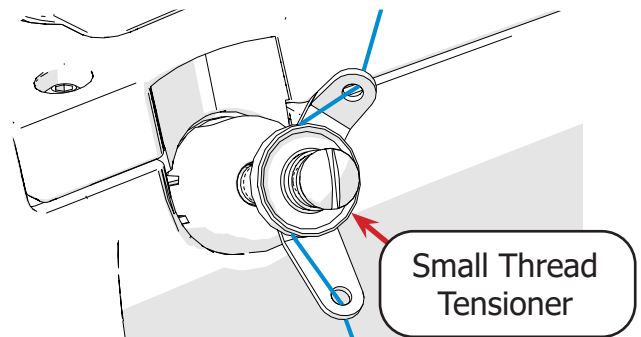

- 6 Pull the thread around the **large thread tensioner**, between the tension discs.

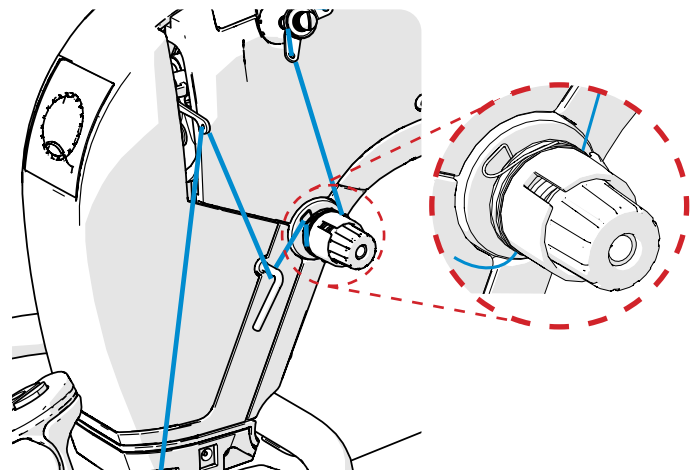

Task 8 - Threading the Machine (continued)

- 7 Wrap the thread over the **check spring**.

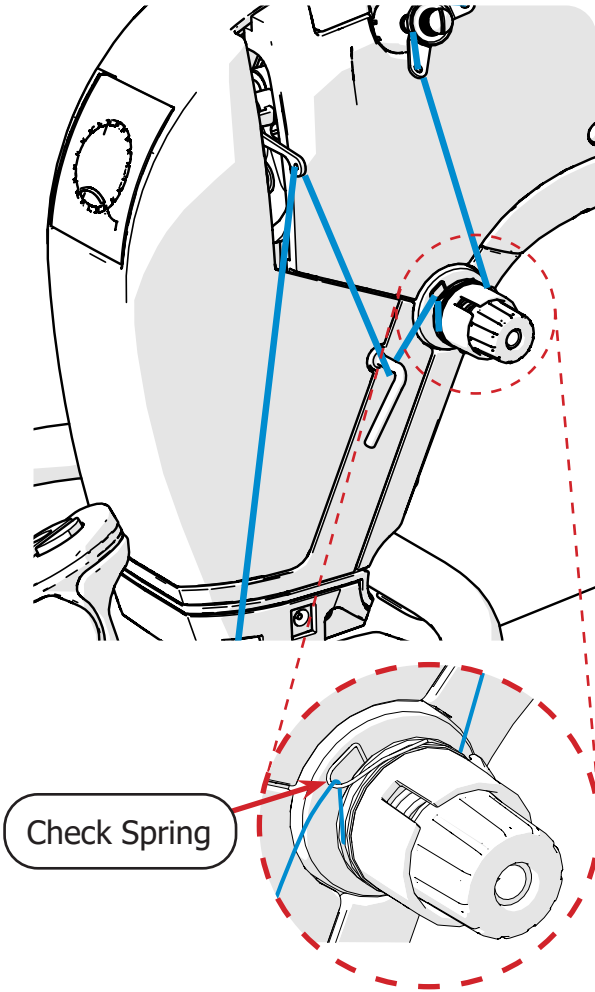

- 8 Next, pass the thread down and around the **thread guide** next to the large thread tensioner.

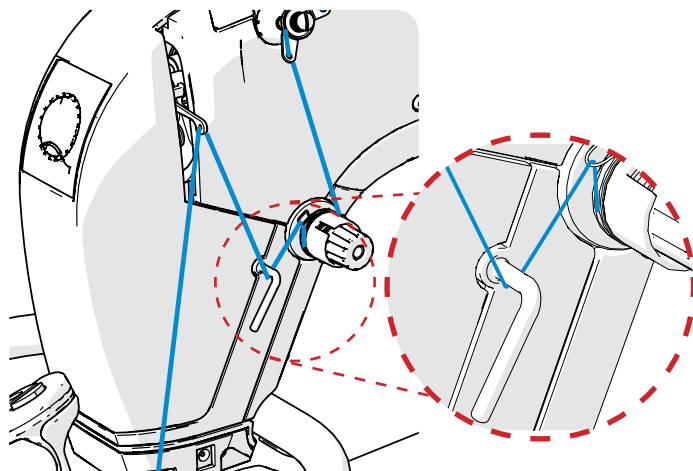

- 9 Pull the thread through the hole in the **take-up lever**.

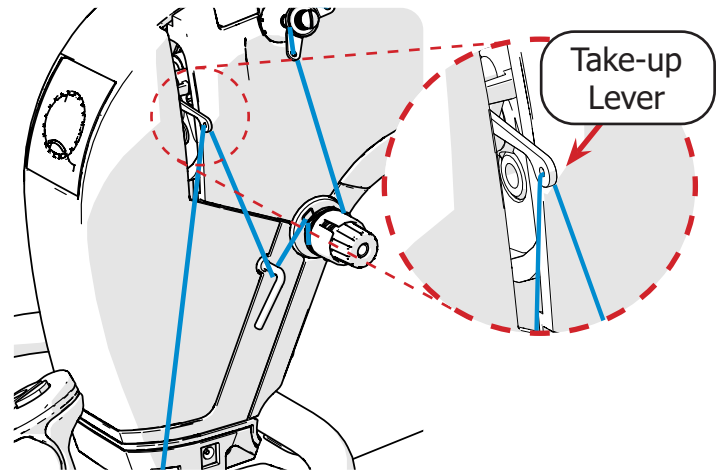

- 10 Then pass the thread down through the **bottom thread guide** on the way to the needle.

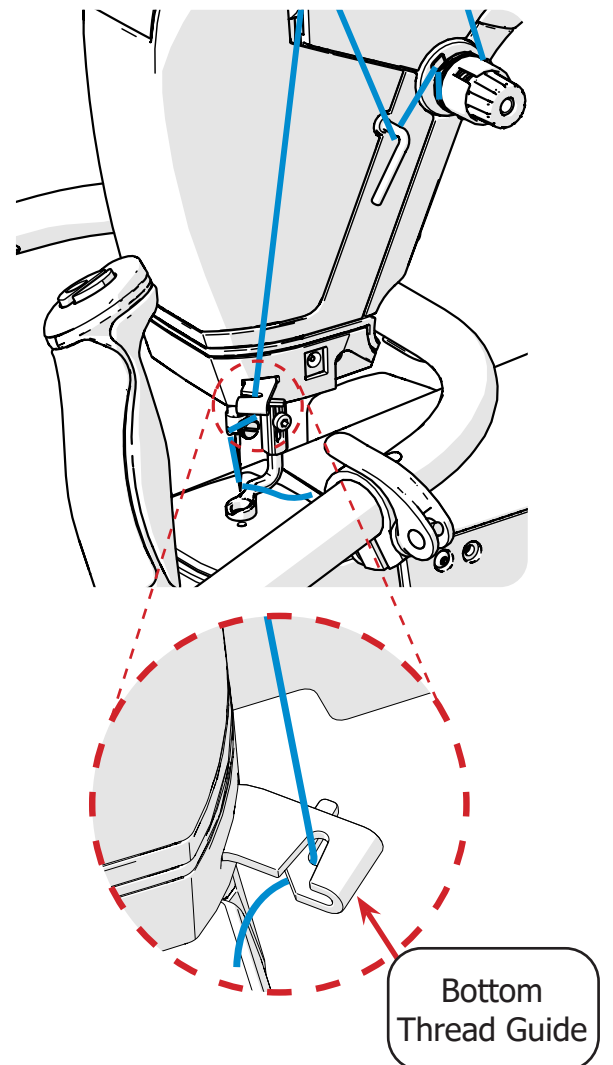

Task 8 - Threading the Machine (continued)

- 11 Now pass the thread through the front of the **needle bar eyelet**, located above the needle. Thread the **eye of the needle** from front to back.

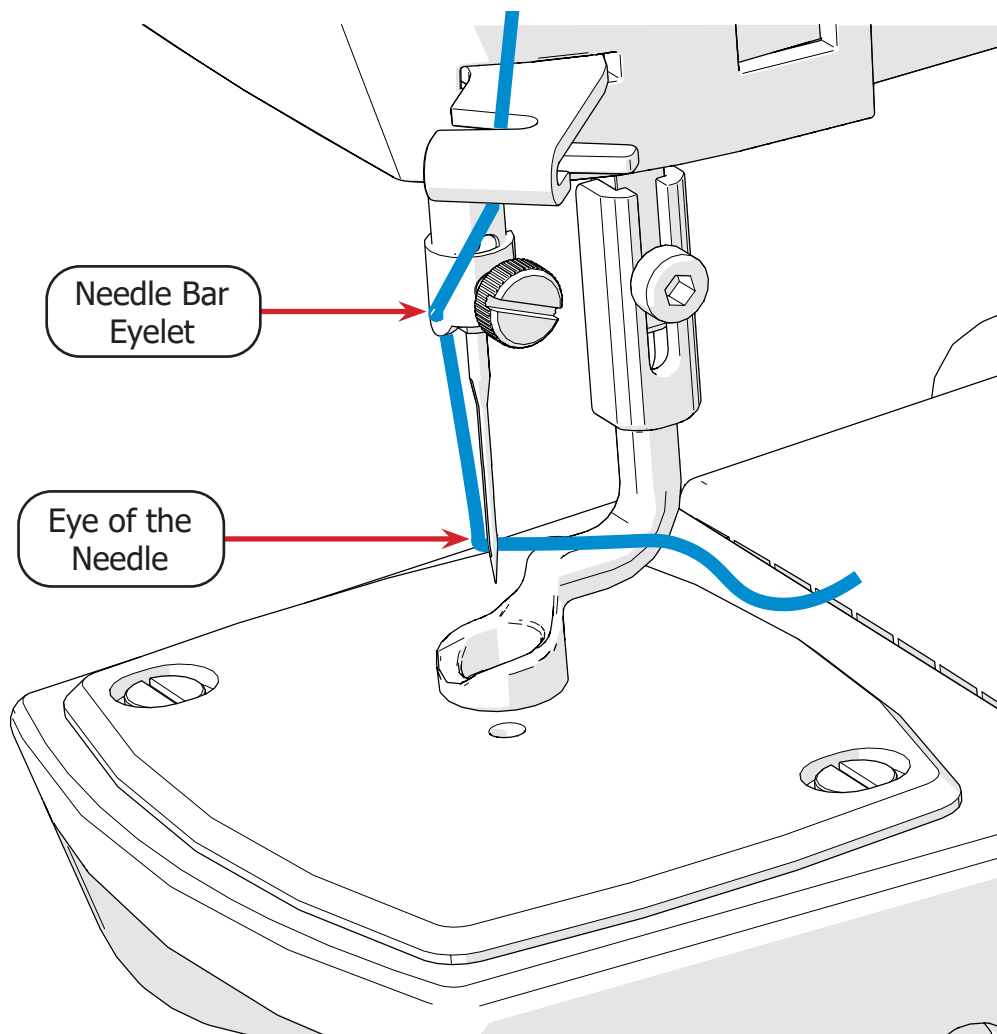

- 12 Cut the excess thread with the built-in **thread cutter** on the side of the hopping foot opposite the bottom thread guide.

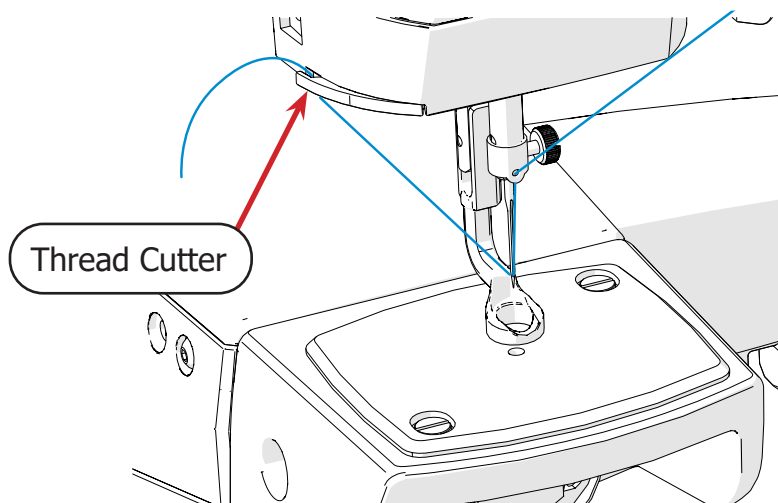

Congratulations! You have completed Part Three of this manual.

If you are assembling a new frame, turn to Part Three of your frame manual. If your frame manual is not broken into parts, follow the manual's directions to:

- Install and adjust the rails
- Install frame handwheel (if applicable)
- Install the bungee clamps (if applicable)
- Adjust the carriage stop (Cutie Frame only)
- Level the frame

If you are not assembling a new frame but are installing QuiltMotion onto your frame, turn to Part Three of your QuiltMotion manual.

If you are installing your machine onto a frame that is already fully assembled and are not installing QuiltMotion at this time, continue to Part Four of this manual on page 41.

Part Four

If your frame isn't fully assembled at this time, it is recommended to complete Part Three in your frame manual, Part Three in your QuiltMotion manual (optional), and Part Four of your frame manual before you continue.

Progress Checkpoint:

Have you:

- Installed your frame's rails?
- Adjusted the rails to work with your machine?
- Installed frame handwheel (applicable frames only)?
- Installed bungee clamps (applicable frames only)?
- Adjusted the carriage stop (Cutie Frame only)?
- Leveled the frame (applicable frames only)?

Have you:

- Completed QuiltMotion Part Three (optional)?

Have you:

- Prepared your frame for fabric installation?
- Installed your quilt onto your frame?

Quilting

Using the Handlebar Controls page 32

Adjusting Thread Tension page 33

Getting Started page 36

Using the Handlebar Controls

Please take a moment to review the handlebar controls. These controls are used when quilting.

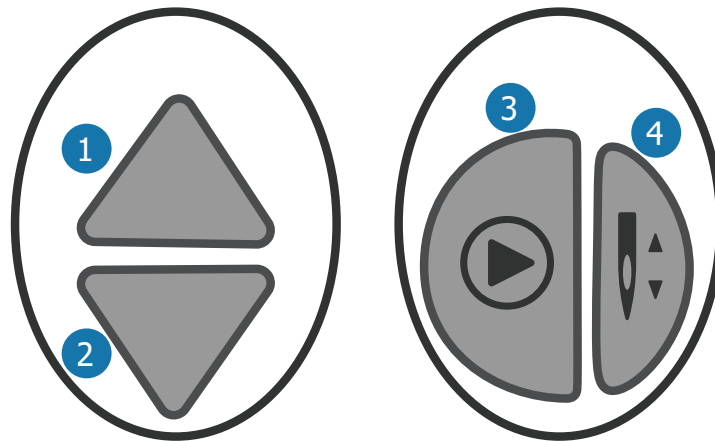

- 1 Increase:** This button increases the speed of the stitching
- 2 Decrease:** This button will decrease the speed of the stitching
- 3 Start/Stop Quilting:** Press to start or stop stitching.
- 4 Needle Button:** Press to toggle the needle between the up and down positions. You can also press and hold for 3-5 seconds to alternate the needle stop position between up and down.

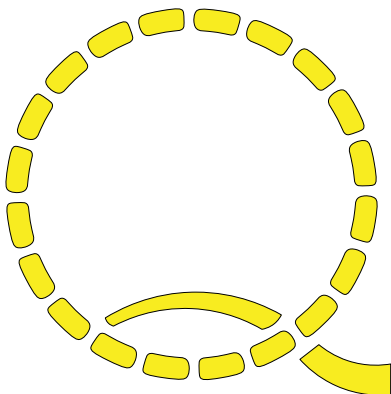

When the machine is first turned on, the Q-display on the front of the machine will light up.

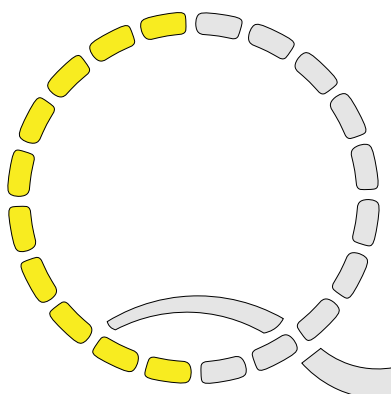

When you are quilting, the Q-display will serve as a speed indicator. For example, if the machine is set at half of the max speed, half of the Q will be lit up. The light will change as you increase and decrease your speed.

Adjusting Thread Tension

Proper thread tension prevents unwanted puckering, poorly-formed stitches, and malfunctions that can damage the fabric. Test your thread tension on extra materials before sewing on a project.

Tip: Bottom thread tension is addressed in “Task 7 - Loading the Bobbin Case” (see page 22). This should be done before adjusting top tension.

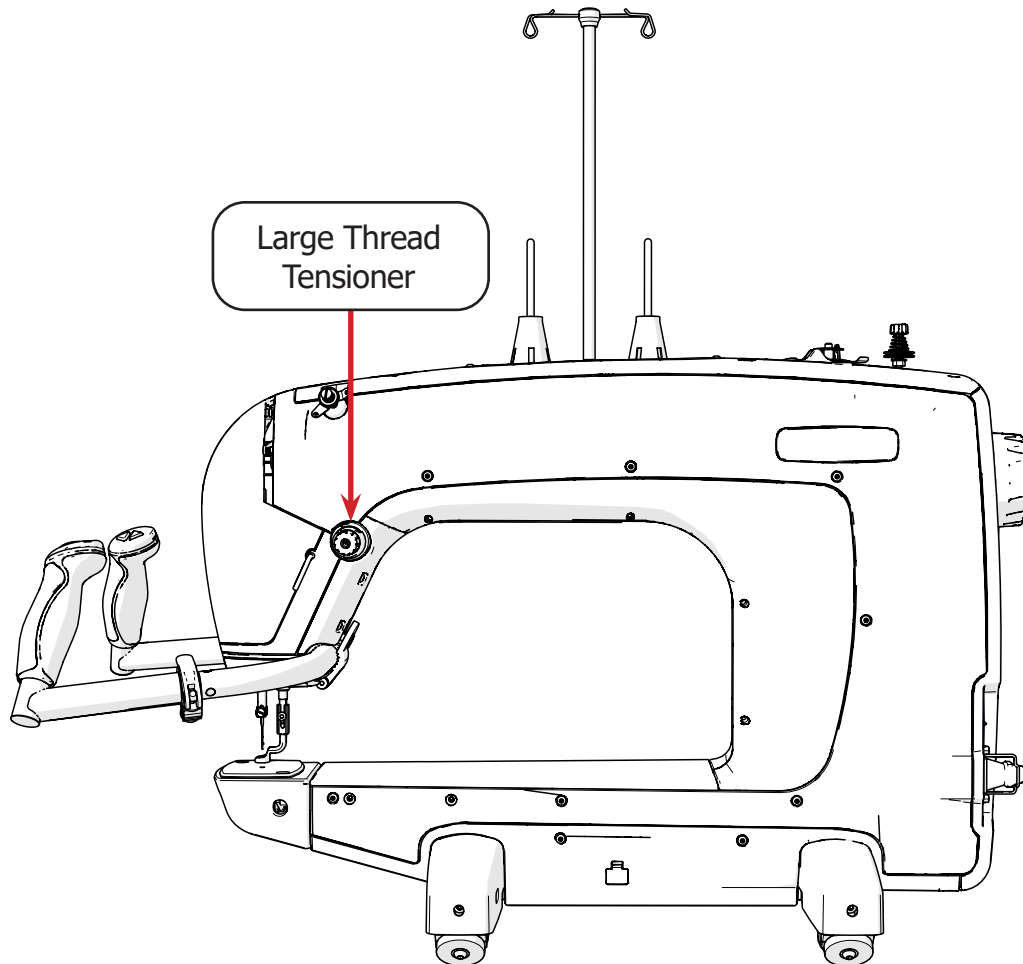

- 1 Loosen the **tension knob** on the **large thread tensioner** to set the tension to “1.” The bottom of the tension knob will line up with the number that the tension is set to.

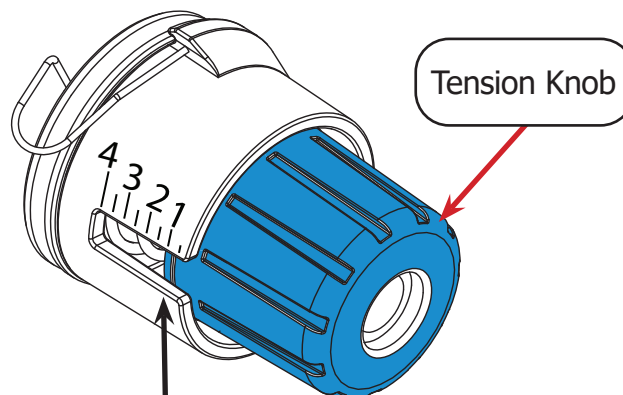

Note: Setting “1” is the lowest tension for your machine, and is an ideal starting place to find the correct top tension.

- 2 Slowly increase the tension while stitching into scrap material. When the thread tension is balanced, the top and bottom thread will knot in the middle of the fabric layers.

Too Much Top Tension



Bottom thread is pulled to the top of the fabric.

Balanced Tension

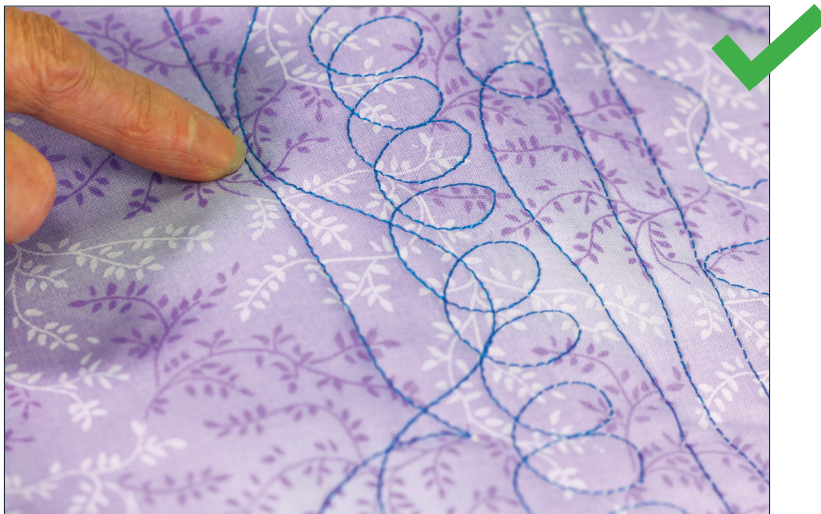

Too Little Top Tension



Top thread is pulled to the bottom of the fabric.

Adjusting Thread Tension (continued)

- If the **bobbin (bottom) thread** is pulled through the top layer of fabric, there is too much top tension. Loosen the tension by turning the large thread tensioner knob toward the setting "1." Stop turning the knob when desired tension is achieved.

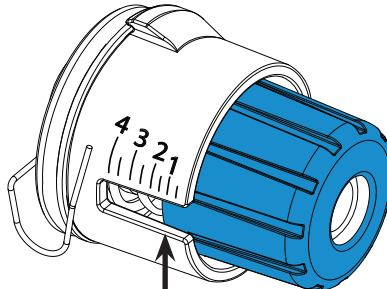

- If the **top thread** is pulled down through the bottom layer of fabric, there is too little top tension. Increase the tension on the top by slowly turning the large thread tensioner knob toward setting "4." Stop turning the knob when desired tension is achieved.

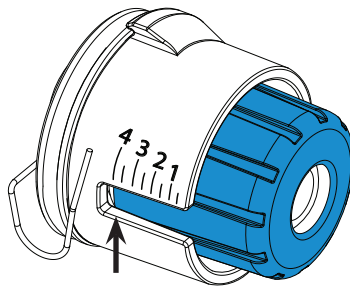

Getting Started

Parts & Tools Needed:

Scissors
(not included)

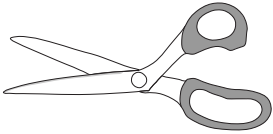

Washable Fabric
Marker/chalk (not
included)

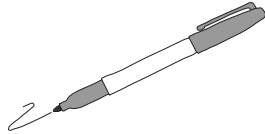

Instructions

With the machine fully assembled, you are ready to begin quilting. Practice on spare fabric to become familiar with the machine's settings and movements so you can start your projects with confidence. It is normal to make mistakes, so don't get discouraged if your stitches don't look perfect right away. Follow the steps in this section to get started and you'll be quilting in no time!

- 1 **Relax!** Take a deep breath and don't be afraid to take it slow.

Make sure that the following items have been completed:

- Your machine is threaded and tensioned.
- Your practice fabric is attached.
- You have established any machine settings you want to use.



- 2 Before you begin stitching, pull up your bobbin thread to prevent the thread tail from dangling underneath the fabric as you quilt and getting sewn in place.

a First, position the needle directly above where you want to begin your pattern.

b Pull on the **top thread** so that it is tight.

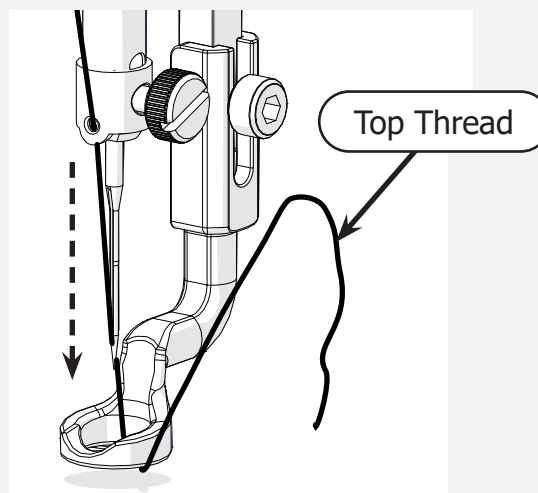

Getting Started (continued)

- c While still tightly holding the top thread, move the machine several inches to the side. Your top thread should pull a loop of **bobbin thread** through the **start point** to the top of the fabric.

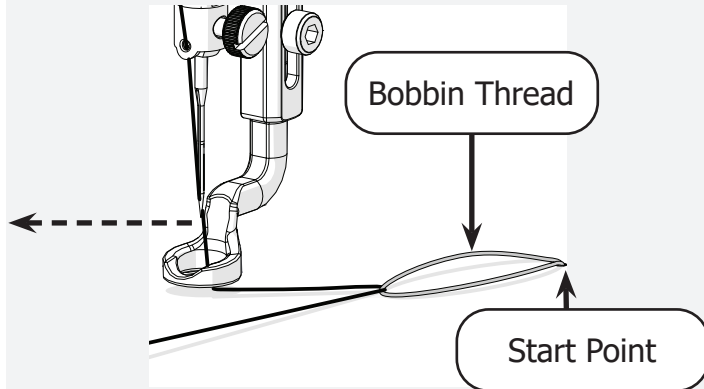

- d Pull on the loop of **bobbin thread** until the loose end of the thread comes up from underneath the fabric.

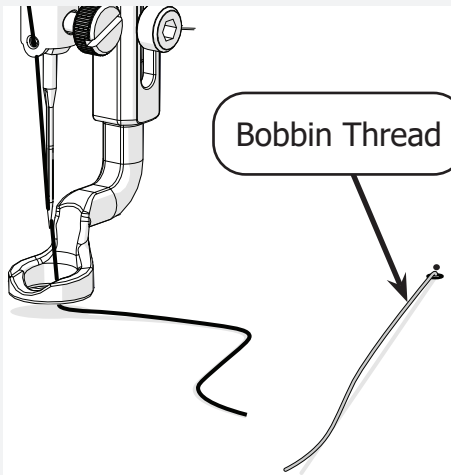

- e Pull on the bobbin thread while moving the machine back to the start point. This makes sure that there is no loose thread underneath the fabric.

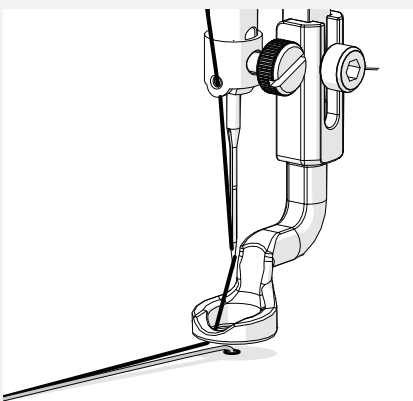

- 3 Begin stitching. Be sure to start your pattern as close as possible to the start point where you pulled out the bobbin thread.

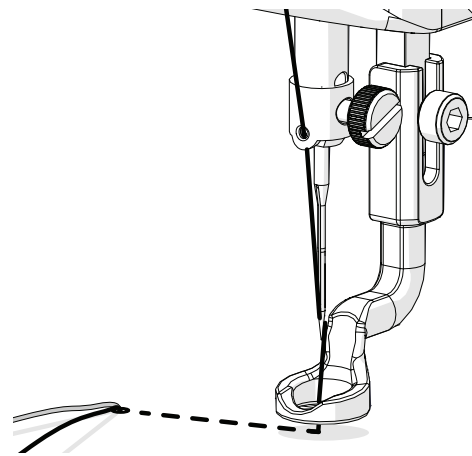

- 4 With fabric chalk or a marker, draw a simple pattern or write your name on the fabric and then stitch over it to practice.

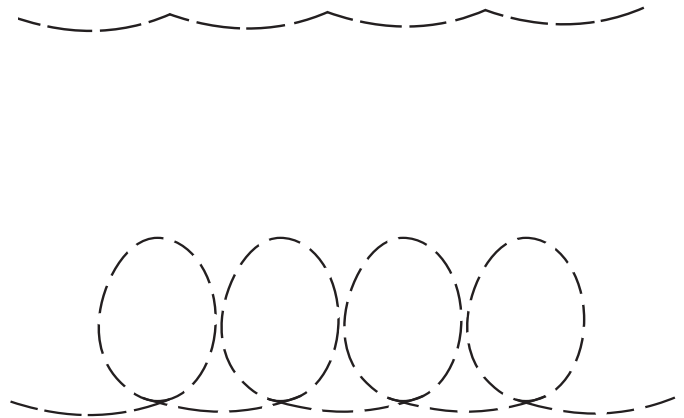

Grace

- 5 Complete the pattern by making a tie-off stitch using the needle button on the handlebars.

- 6 To pull up the bobbin thread after making a tie-off, take the following steps:

- a Move the machine away from the tie-off stitch.

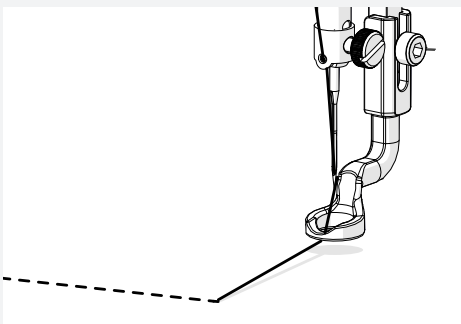

- b Hold the thread to make a loop and return the machine to the tie-off stitch.

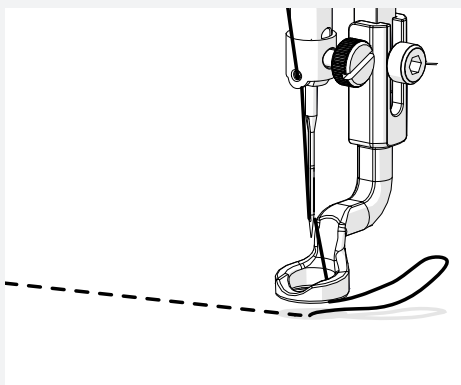

- c Make a single stitch over the tie-off.

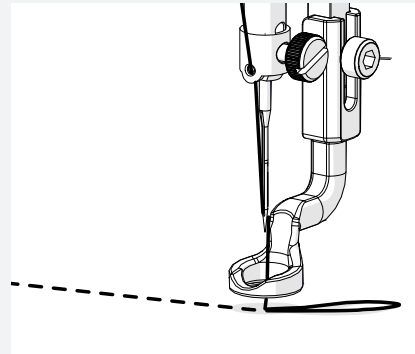

- d Hold the loop and move the machine away from the tie-off again.

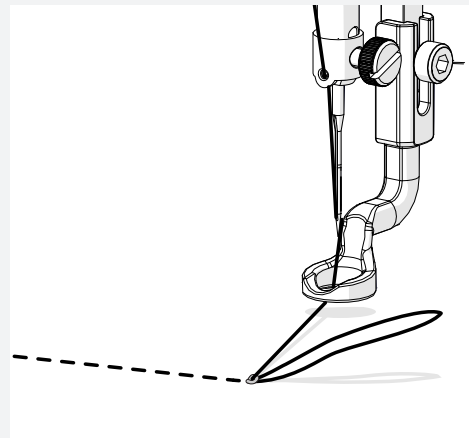

- e Keep moving away from the tie-off until a loop of bobbin thread is pulled up above the fabric. Cut all threads close to the tie-off.

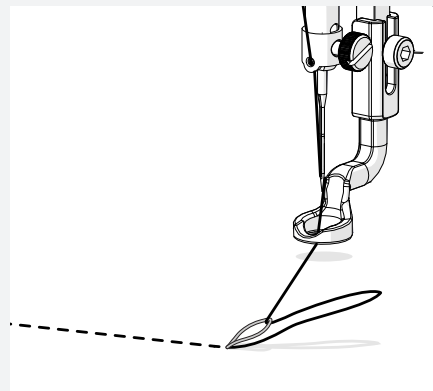

- 7 You may now cut the thread tails from the beginning of the pattern.

Practice! Keep trying different stitches until you feel comfortable with how your machine feels and moves. You can always attach a new practice quilt if you need to.

Congratulations! Now that you have practiced and gotten used to the basic settings and movements of your machine, you are ready to begin your quilting journey.

If you have any accessories that you have not installed yet, you may do so now.

Good luck, and thank you again for choosing The Grace Company to help with your quilting needs.

Maintaining the Machine

Keep your machine performing at its peak by practicing good machine maintenance habits.

This section of the manual covers oiling the machine, changing the needle, adjusting the hopping foot, reinstalling the needle plate, and reinstalling the anti-backlash spring.

Preparing the Oil Bottle	page 41
Oiling and Cleaning	page 42
Changing the Needle	page 46
Adjusting the Hopping Foot	page 48
Reinstalling the Needle Plate	page 51
Reinstalling the Anti-Backlash Spring	page 53

Preparing the Oil Bottle

Parts & Tools Needed:

Oil Bottle

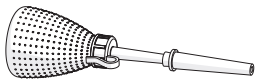

Scissors

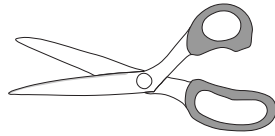

Power Cord/Oil Bottle Box

(Not included)

Instructions

Take the following steps to prepare the oil bottle for use in oiling the machine.

- 1 Snip off about 1/4th of an inch from the tip of the plastic lid with a pair of scissors.

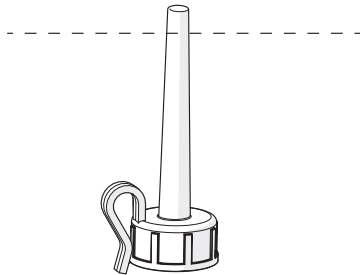

- 2 Place the applicator needle onto the top of the cap.

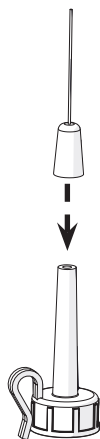

- 3 Peel the safety foil off the opening of the oil bottle.

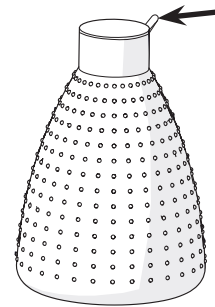

- 4 Carefully screw the lid onto the oil bottle.

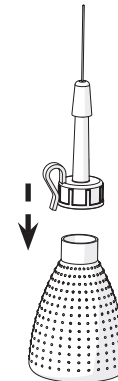

- 5 Hold bottle upside down and squeeze gently to apply oil. When not in use, cover the applicator needle with the safety cap.

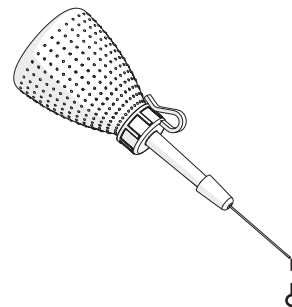

Oiling and Cleaning

Parts & Tools Needed:

Lint Brush



Oil Bottle

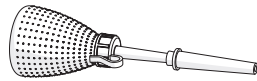

- Compressed Air Can (optional; not included)

Tools Box

Instructions

Oil and Clean:

Machine	<ul style="list-style-type: none"> • At the start of a new project • After 20 hours of use • After sitting without use for more than 30 days
Hook Assembly	<ul style="list-style-type: none"> • Every other bobbin change

Take the following steps to clean and oil the machine:

- 1 Power off the machine.
- 2 Set the **large thread tensioner** to "1" to expose the tensioner discs. Use the lint brush or a can of compressed air to clear away lint and thread remnants from between the discs.

Note: Lint build-up between the tensioner discs can prevent proper thread tensioning.

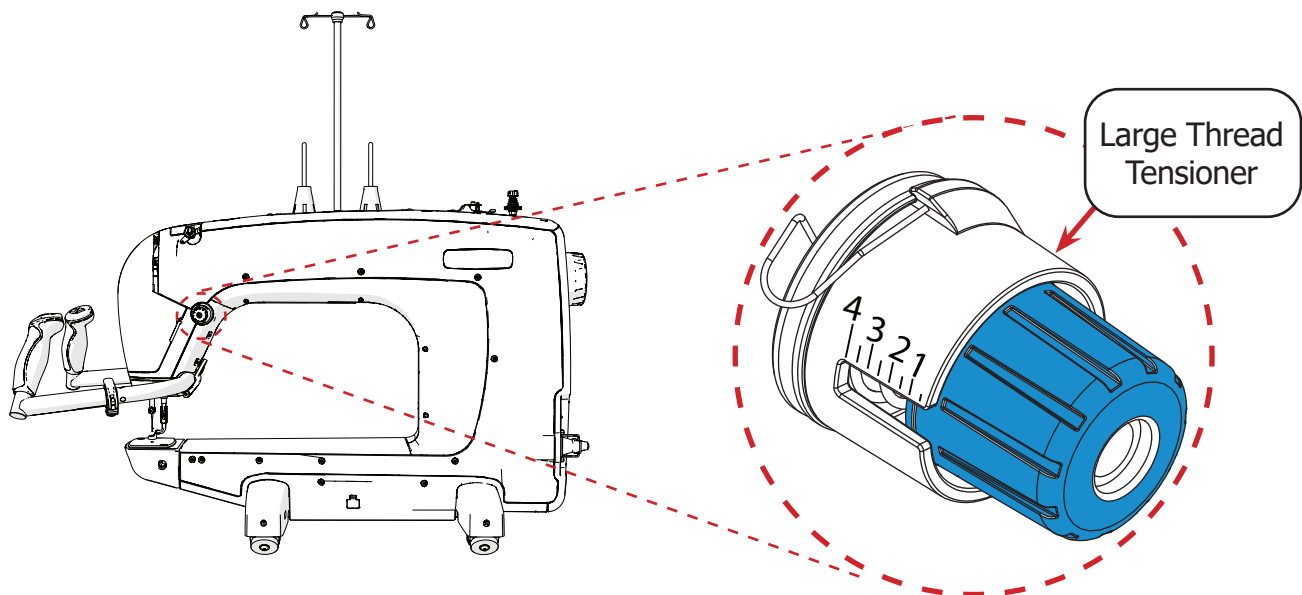

Oiling and Cleaning (continued)

- 3 Clear debris from the spring and discs of the **small thread tensioner**.

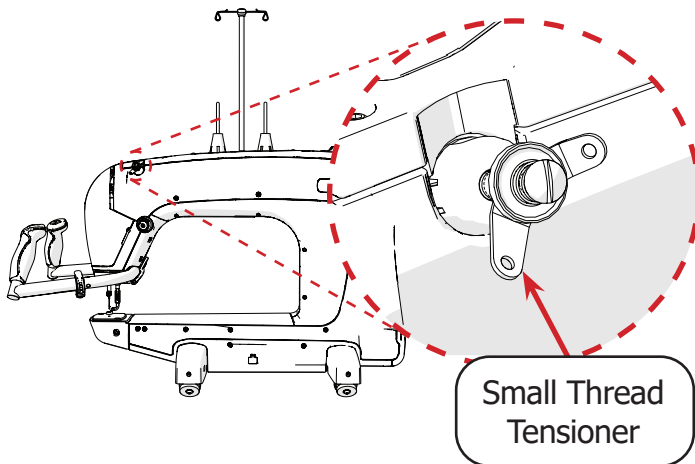

- 4 Pull the **release lever** (shown in blue) on the bobbin case to remove it from the hook assembly. If the case won't release, raise the needle with the hand wheel at the rear of the machine.

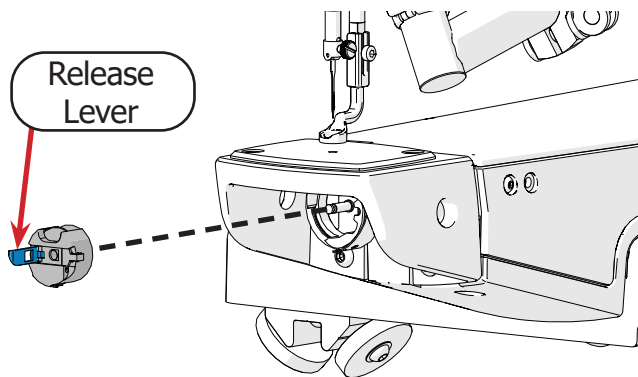

- 5 Set the bobbin aside. Clean the bobbin case with the lint brush or compressed air. Be sure to clean the area under the **bobbin tension thread arm**.

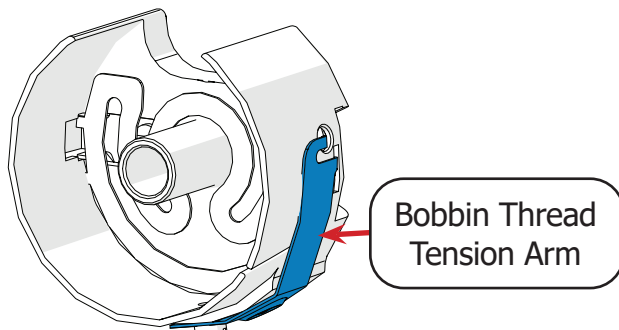

- 6 In and around the **hook assembly**, clear away any lint, cloth, and thread remnants.

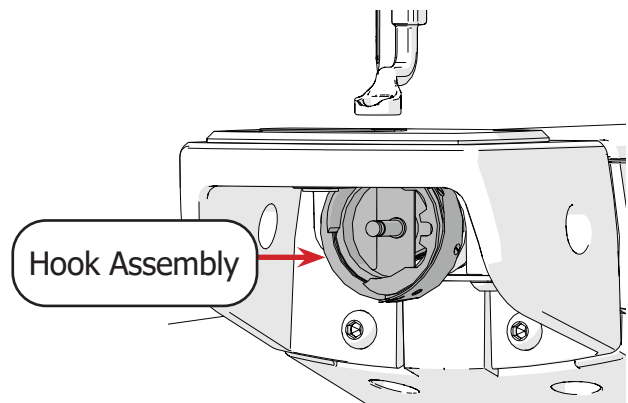

- 7 Rotate the **hand wheel** until the needle is halfway down. This will put the hook in the best position for oiling.

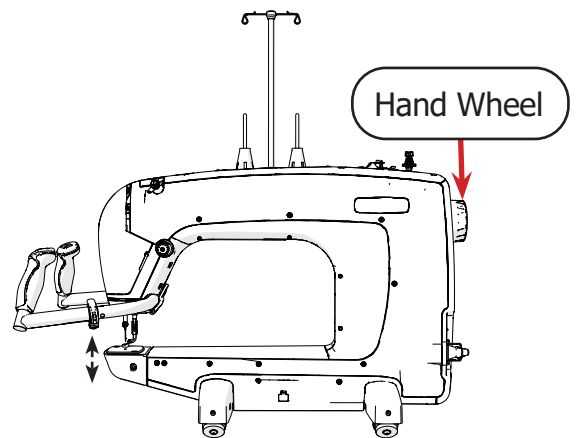

- 8 Place one to two drops of oil into the hook assembly between the **inner part** (shown in gray) and **outer part** (shown in blue).

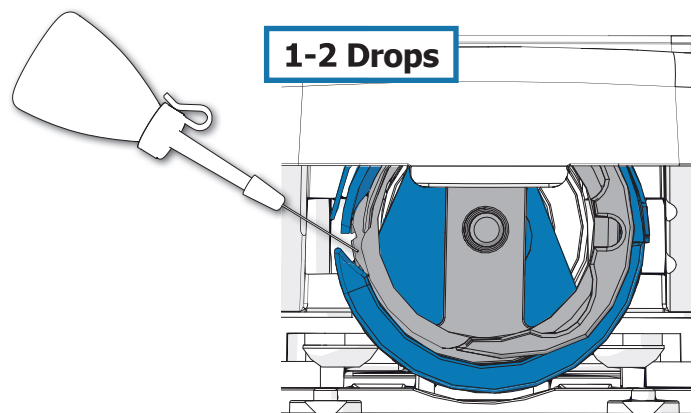

- 9 Pull on the sides of the front cover of the machine to open the cover and access the **needle bar** and **presser bar**.

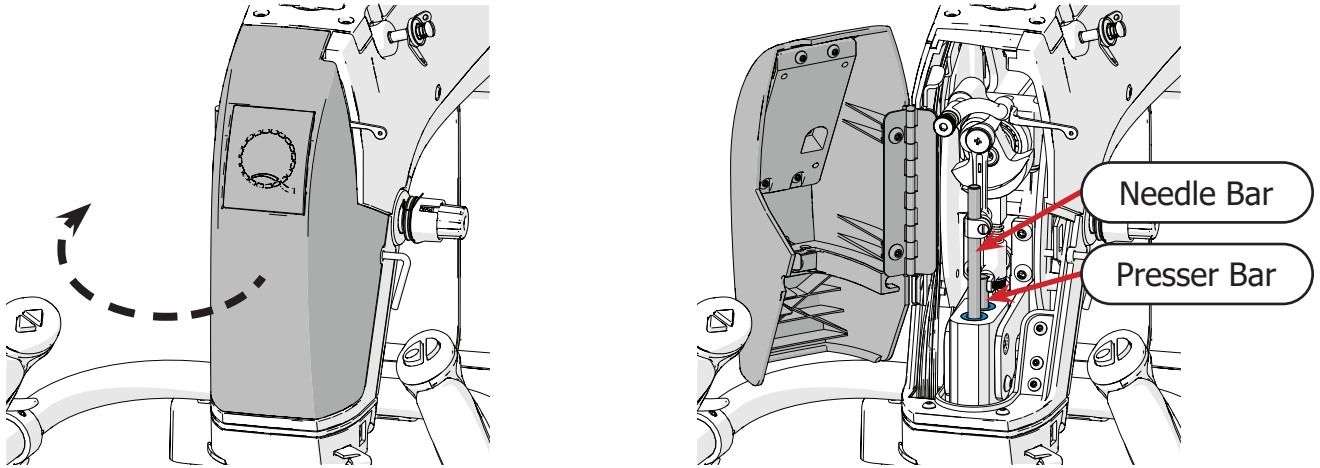

- 10 Place 1-2 drops of oil at the bottom of the needle bar and presser bar where they meet the bushing block.

Close the front cover when finished.

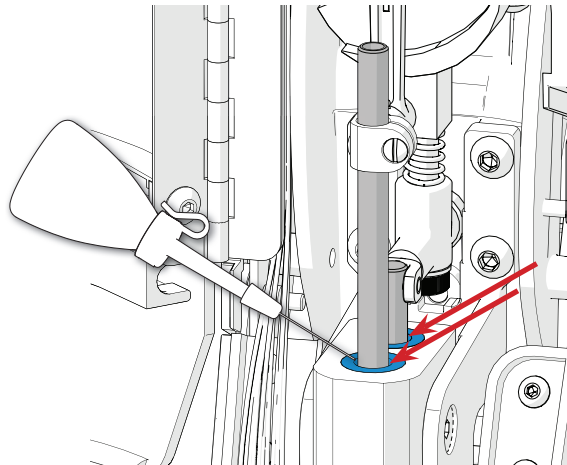

- 11 Power up the machine and run it for about ten seconds to evenly spread the oil around the hook assembly.

Oiling and Cleaning (continued)

- 12 Reload the bobbin case and return it to the machine (for detailed instructions on tensioning the bobbin case, see page 22).

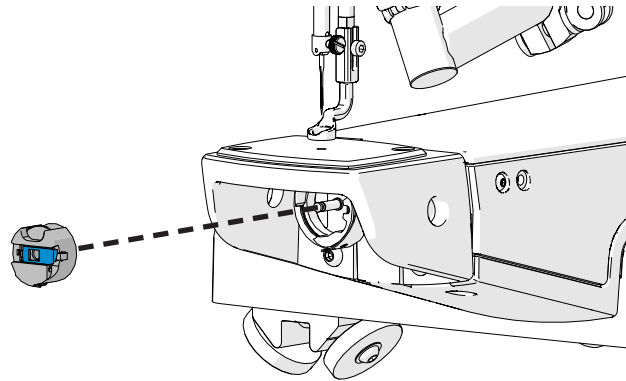

- 13 Regularly wipe down the **needle bar** to prevent the accumulation of oil that can stain your fabric.

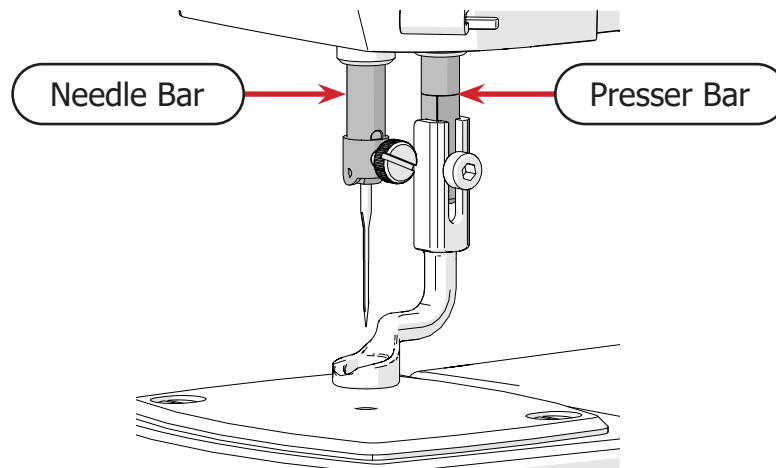

Changing the Needle

For information on selecting a needle, see "Choosing Your Needle" on page 64.

Parts & Tools Needed:

Needle



Tools Box

Needle Magnet

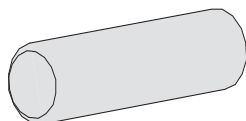

Tools Box

Flat-head Screwdriver

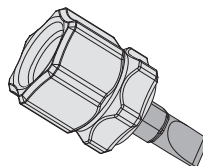

Tools Box

Instructions

A broken, bent, or burred needle may break thread, damage fabric, or even damage the machine. Always check that the needle is in good condition before starting a new project, and replace the needle after eight hours of use.

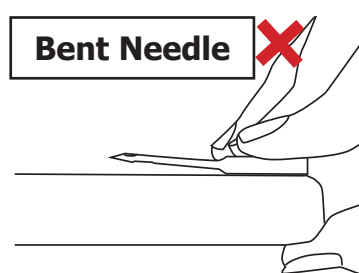
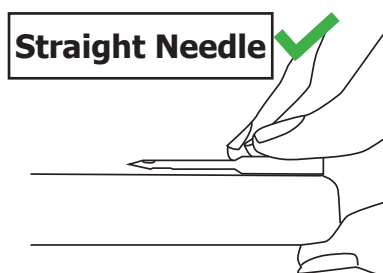

To avoid damage to the machine, please choose an approved needle style from the list below:

- DPX5 MR
- 134 MR
- 1955 MR



- 1 Power off the machine.
- 2 Raise the needle to the highest position with the **hand wheel**.
- 3 Loosen the **needle bar thumb screw** and pull out the needle. If needed, use a flat-head screwdriver to loosen the screw.

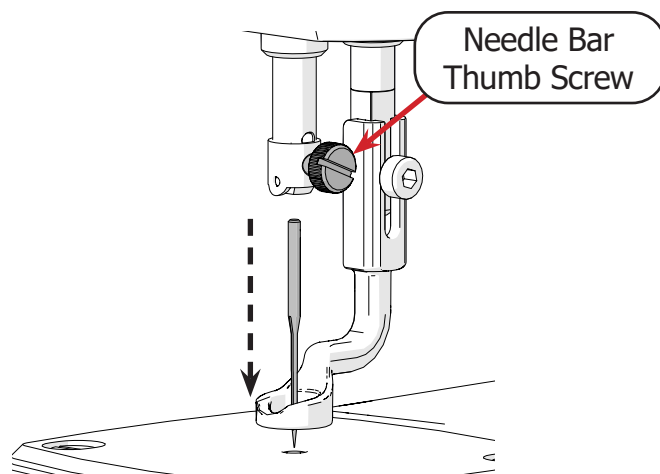
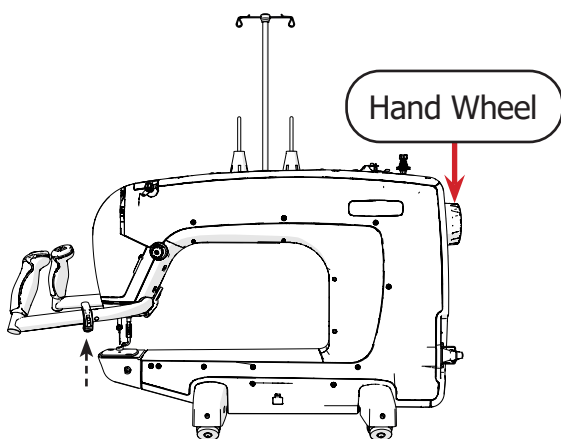

Changing the Needle (continued)

- 4 Insert the new needle all the way into the needle bar. Check the **needle bar sight hole** above the thumb screw to make sure the **needle** is inserted all the way.

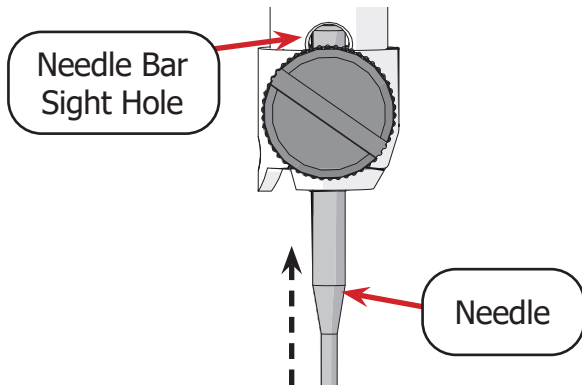

- 5 The **scarf**, a cut-out on the back of the needle, should face the throat of the machine. Place the **needle magnet** on the opposite side of the scarf.

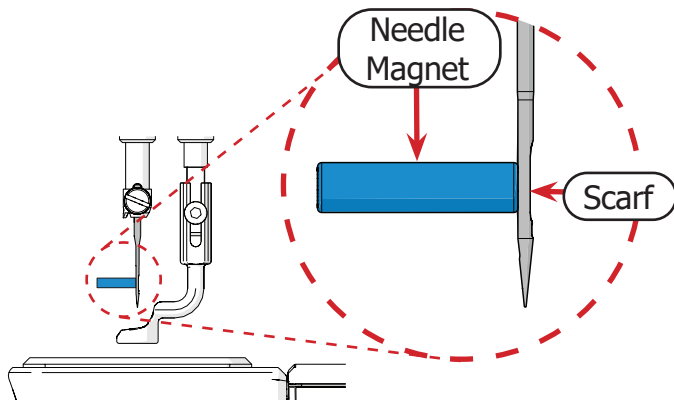

- 6 Use the needle magnet as a visual guide. Twist the needle until the **magnet** (shown in blue) points as straight out from the machine as possible. **Note:** Do not attempt to adjust the needle by moving the magnet directly.

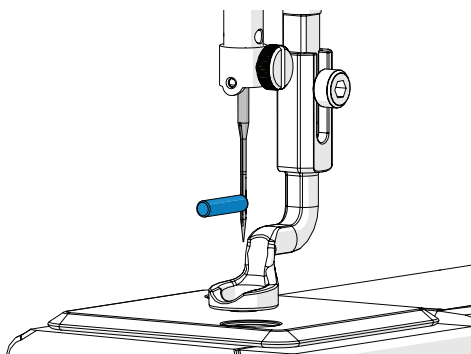

- 7 Hand-tighten the **needle thumb screw**. Do not over-tighten if using the flat-head screwdriver.

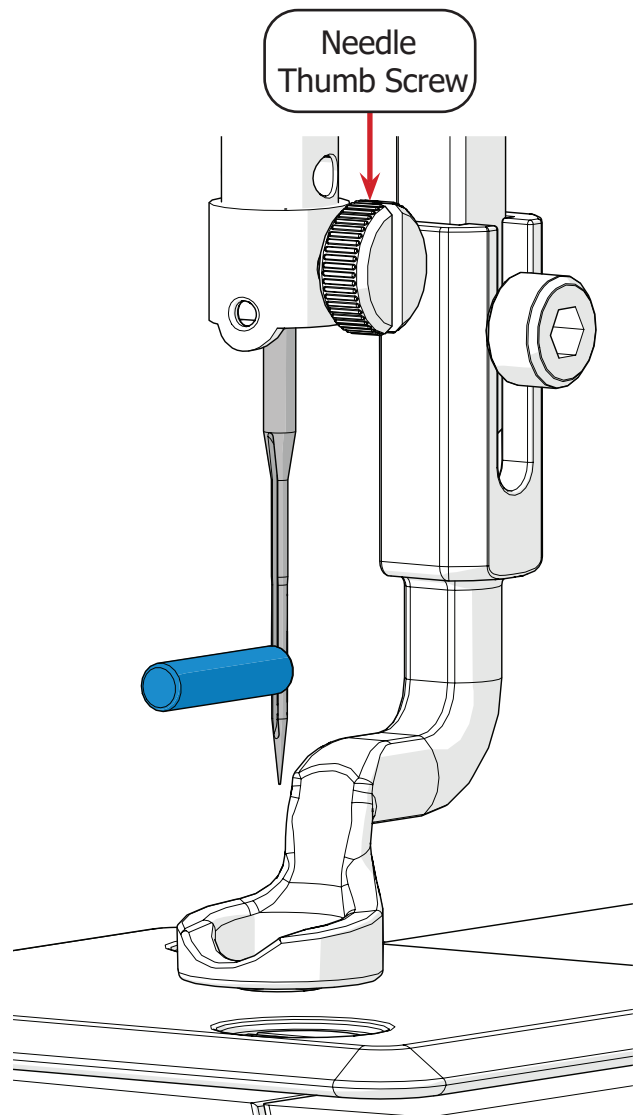

Adjusting the Hopping Foot

Parts & Tools Needed:

T-handle Allen
Wrench 3 mm

Hopping Foot
Height Tool

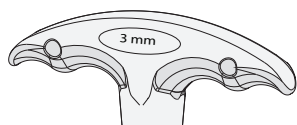

Tools Box



Tools Box

Height Adjustment

When quilting with thick fabric or batting layers, the hopping foot may press down on the quilt too tightly and begin to drag. Alternatively, having the hopping foot too high can result in skipped stitches. The hopping foot can be raised or lowered to correct these problems.

To adjust the hopping foot height, take the following steps:

- 1 Move the machine so it is not over fabric. Then use the **hand wheel** to drop the needle bar to the lowest position.
- 3 Slide the **hopping foot height tool** (shown in blue) underneath the hopping foot with the needle inside the slot.

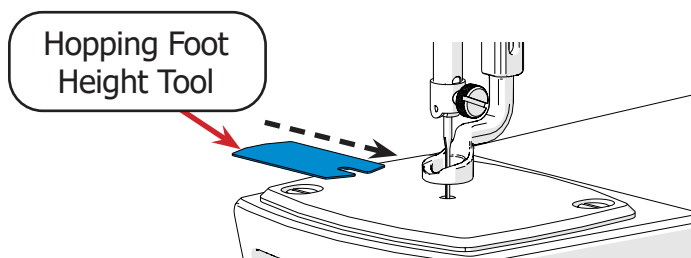
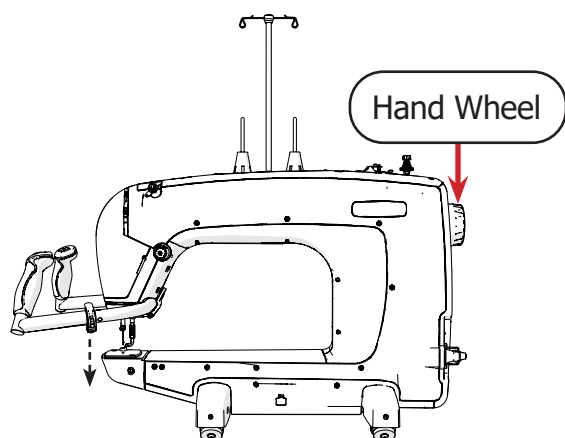

Note: The height tool prepares the machine for standard sized quilt batting and two layers of fabric. For thicker quilts, stack sheets of printing paper over the gauge to increase room underneath the hopping foot.

- 2 Use the 3 mm Allen wrench to loosen, but not remove, the **hopping foot screw**.
- 4 Lower the hopping foot until it rests on the height tool. Re-tighten the hopping foot screw with the 3 mm Allen wrench.

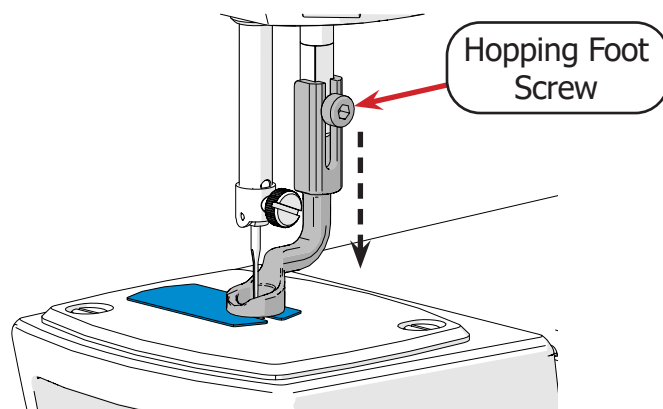
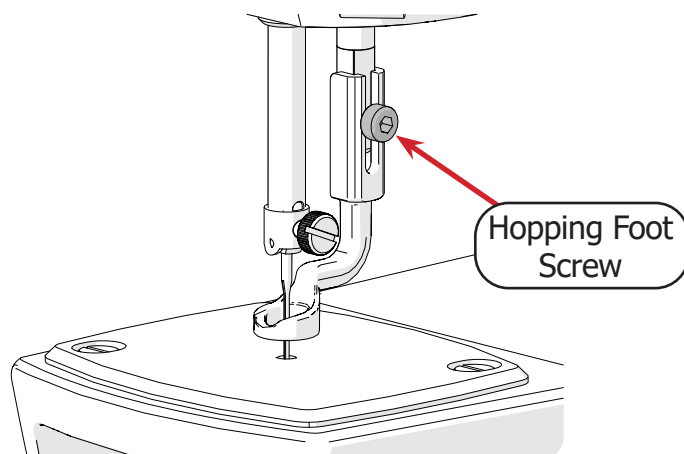

Adjusting the Hopping Foot (continued)

Removal Instructions

To remove the hopping foot for maintenance or to adjust the hopping foot angle, take the following steps:

- 1 Power off the machine.
- 2 Rotate the **hand wheel** to lift the needle from the inside of the hopping foot.

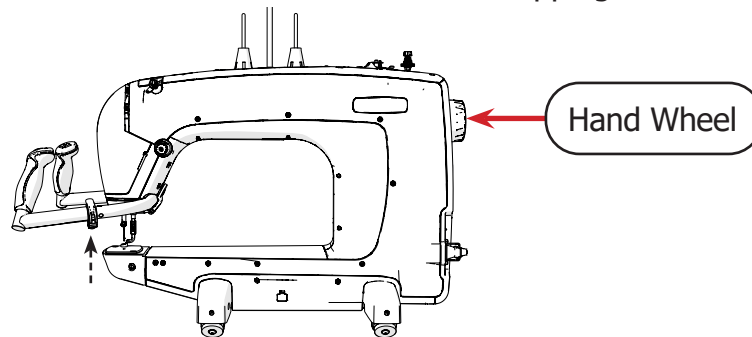

- 3 Use the 3 mm Allen wrench to remove the **hopping foot screw** and **the hopping foot**.

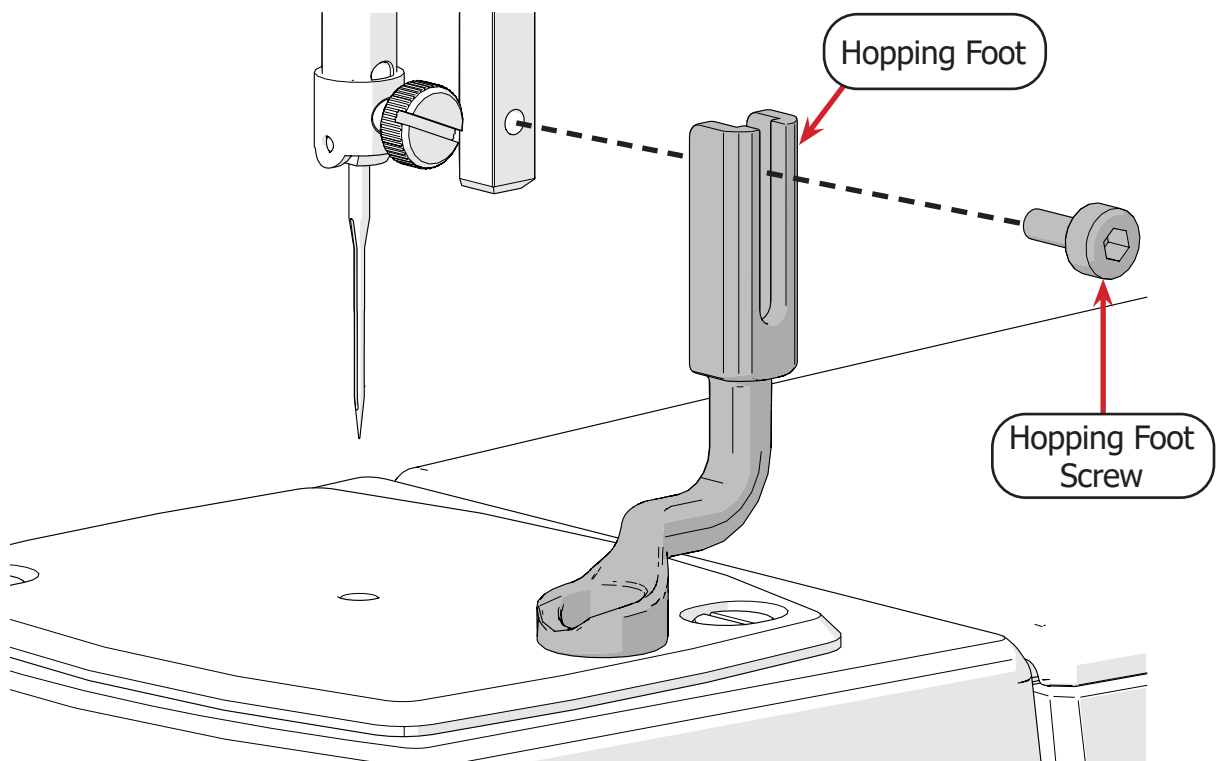

Installation Instructions

To install the hopping foot on your quilting machine, please take the following steps:

- 1 Power off the machine.
- 2 Slide the **hopping foot** onto the **hopping foot collar**. Use the 3 mm Allen wrench and **hopping foot screw** to hold it in place, but do not tighten.

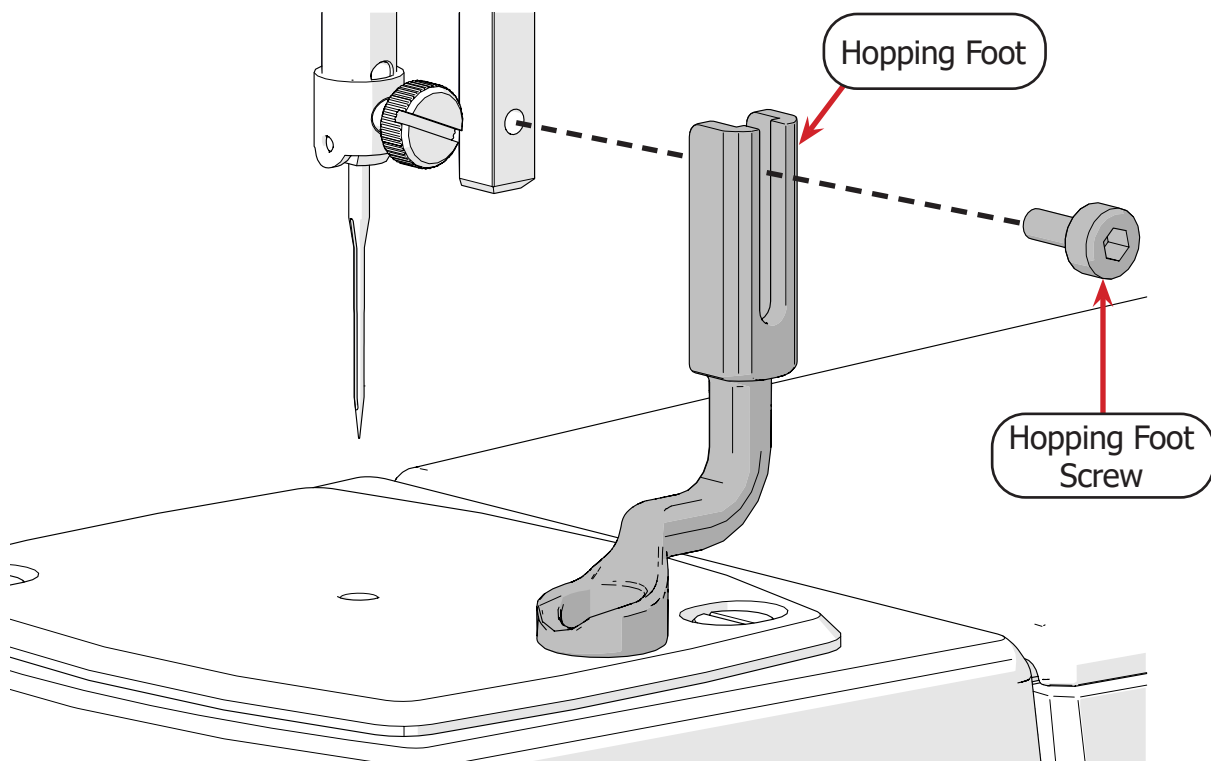

- 3 Adjust height as needed (see page 48).

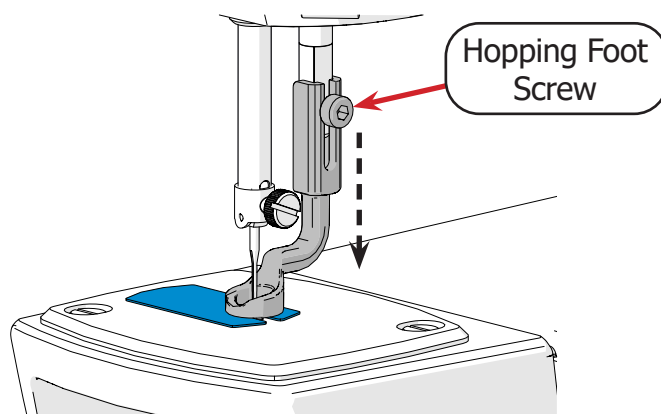

Reinstalling the Needle Plate

Parts & Tools Needed:

Flat-head Screwdriver

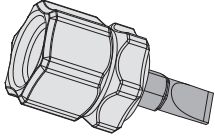

Tools Box

Removal Instructions

To remove the needle plate from the quilting machine, take the following steps:

- 1 Power off the machine and raise the needle to the highest position using the **hand wheel**.

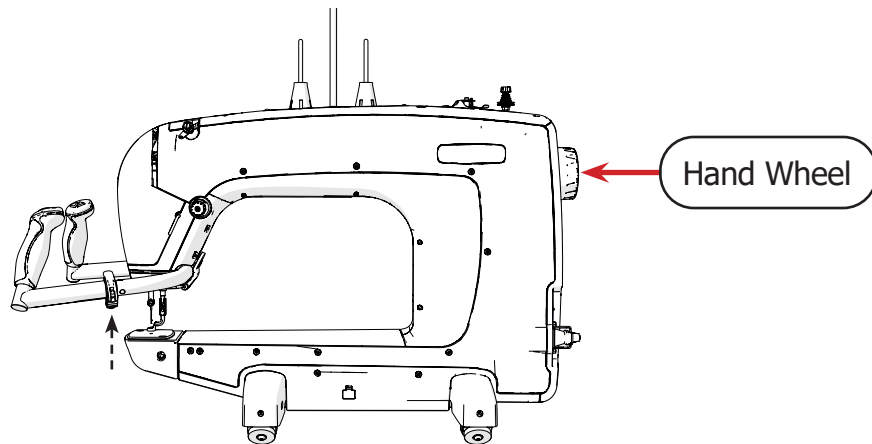

- 2 Use the flat-head screwdriver to remove the two **needle plate screws** (shown in gray).

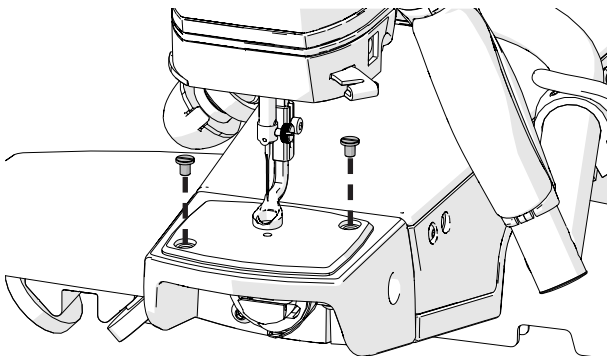

- 3 Slide the **needle plate** (shown in gray) from the machine.

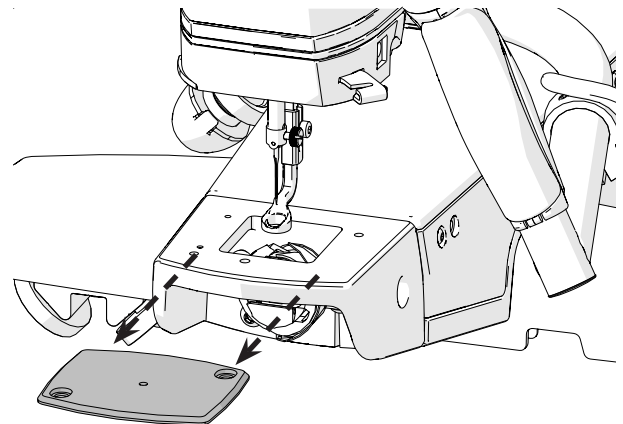

Installation Instructions

To install the needle plate onto the quilting machine, take the following steps:

- 1 Power off the machine. Raise the needle to the highest position using the **hand wheel**.

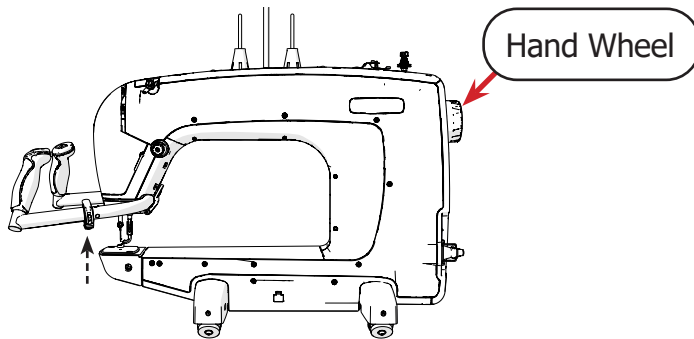

- 2 Slide the **needle plate** (shown in gray) onto the machine.

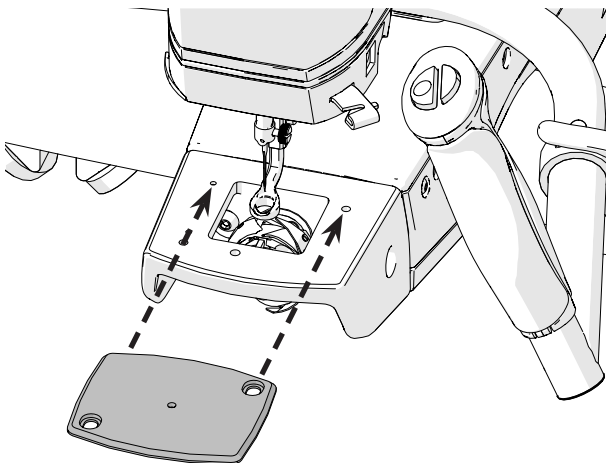

- 3 Slowly lower the needle with the hand wheel. The needle should slide into the center hole without contacting the needle plate.

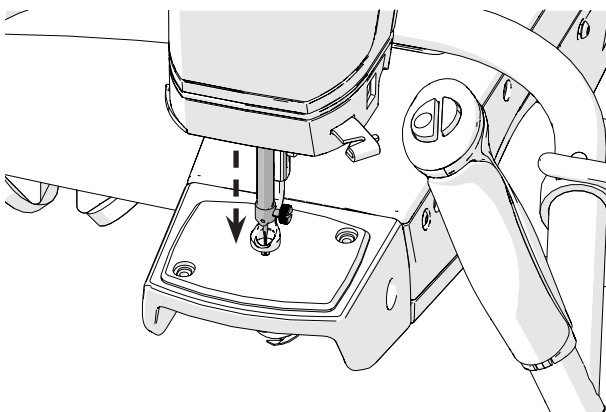

- 4 Align the screw holes on the needle plate with those on the machine.

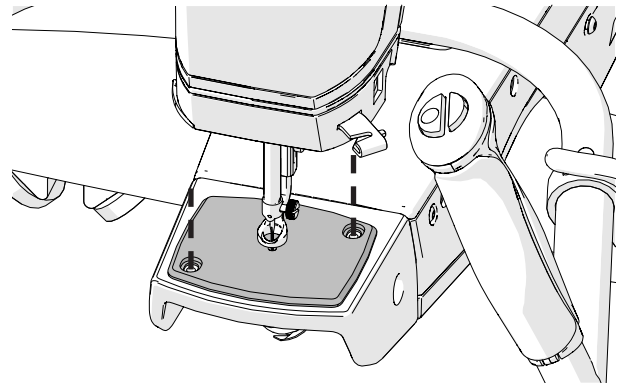

- 5 Place the two **needle plate screws** (shown in gray) into the plate. Make sure the needle plate is centered around the needle, and then tighten the screws with the flat-head screwdriver.

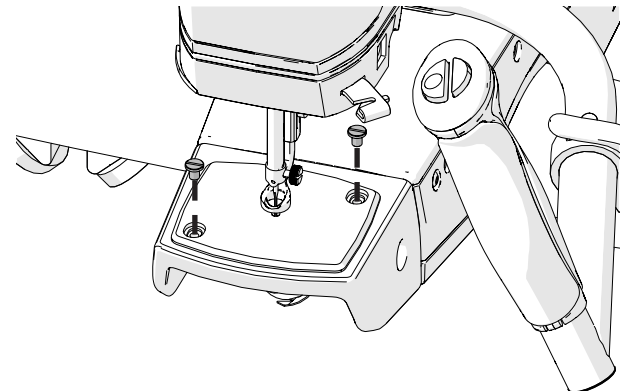

- 6 Use the **hopping foot height tool** to adjust the height of the hopping foot.

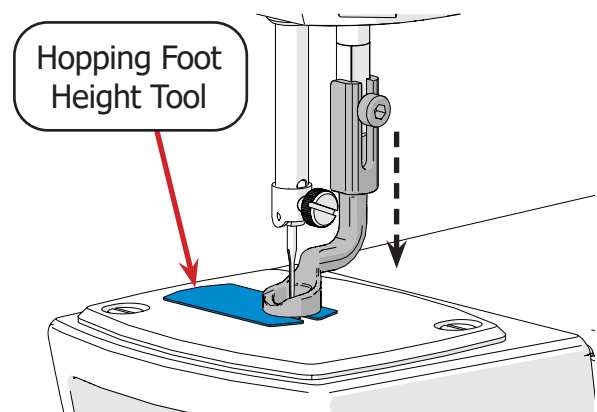

Reinstalling the Anti-Backlash Spring

Parts & Tools Needed:

Flat-head Screwdriver

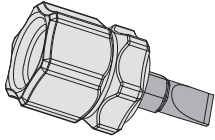

Tools Box

Instructions

Take the following steps to reinstall or replace the anti-backlash spring in the bobbin case if it has fallen out:

- 1 Lay the bobbin case face-down so that the opening is facing up.

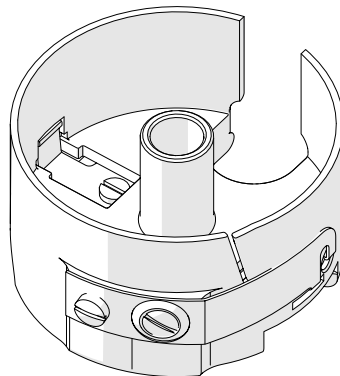

- 2 Position the **anti-backlash spring** so that the **center** section is raised above the edge of the spring.

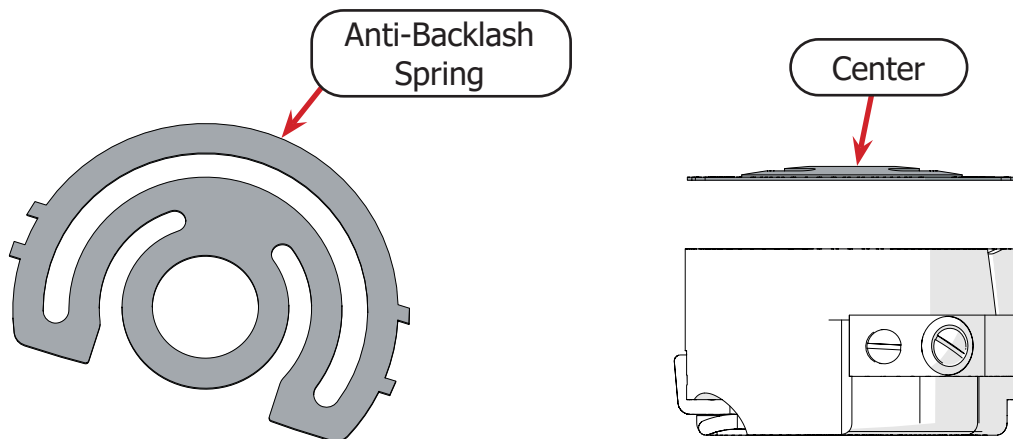

Reinstalling the Anti-Backlash Spring (continued)

- 3 Place the spring inside the bobbin at an angle and press the **tabs** that are closer together into their **slot** on the side.

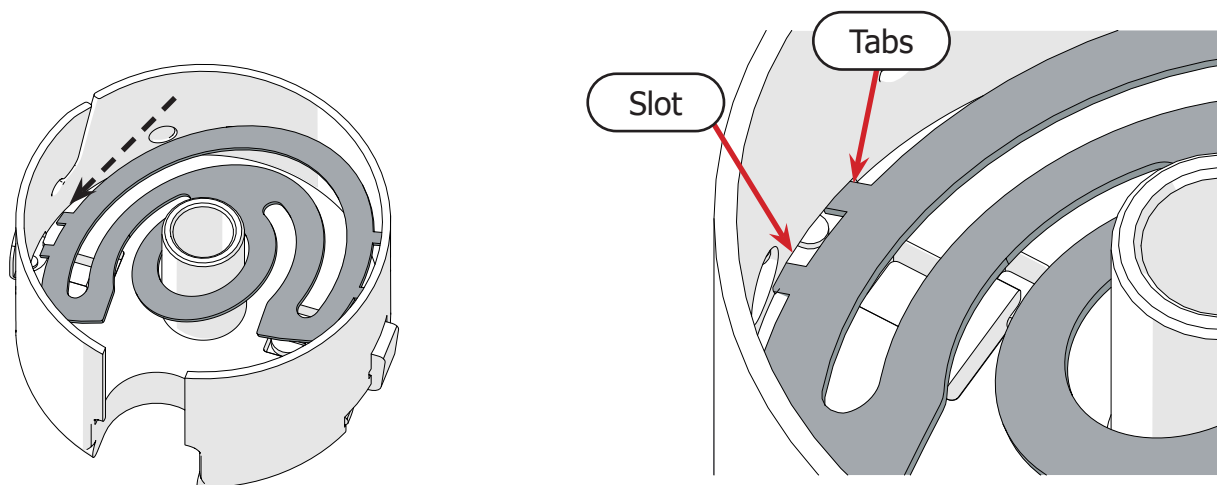

- 4 Press the other side of the spring down and insert the other tabs on the other side. Use the small flat-head screwdriver to make sure all four tabs are fully secured.

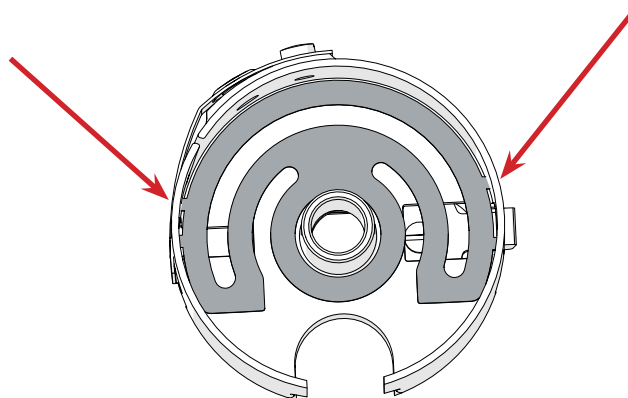

- 5 Place the **bobbin** in the bobbin case. The anti-backlash spring should hold the bobbin so that it barely pokes out of the opening of the bobbin case.

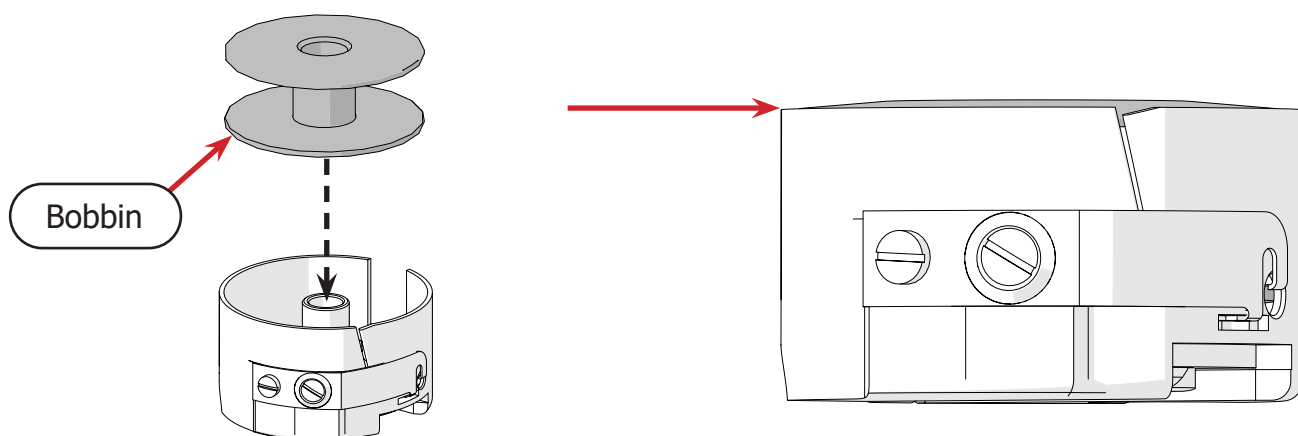

Repairs and Diagnostics

The instructions in this section should only be taken at the direction of a Grace Company support technician. If you are experiencing problems with your machine, please contact our technical support team:

- **Phone:** (800) 264-0644
- **Email:** support@graceframe.com

This section of the manual covers replacing the encoder spring, installing the hook holder, timing the machine, and checking the machine and display software versions.

Reinstalling the Hook Holderpage 56

Timing the Machinepage 59

Reinstalling the Hook Holder

Please speak to a Grace Company support technician before attempting these instructions.

Parts & Tools Needed:

T-handle Allen Wrench 3 mm

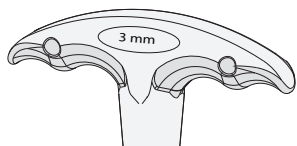

Tools Box

Flat-head Screwdriver

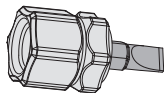

Tools Box

Removal Instructions

The hook holder keeps the hook assembly in place. The following procedure should only be attempted if determined necessary by a Grace Company support technician. If done incorrectly, major machine problems can result.

- 1 Power off the machine and raise the needle to the highest position using the **hand wheel**.

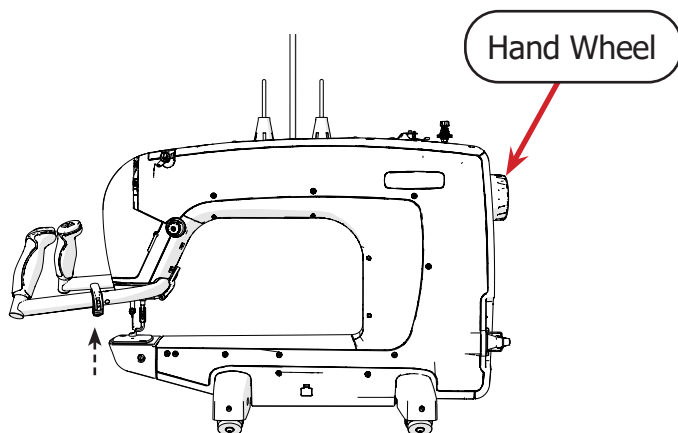

- 2 With the 3 mm Allen wrench, remove the **hook holder screw** (shown in gray) that attaches the hook holder to the machine.

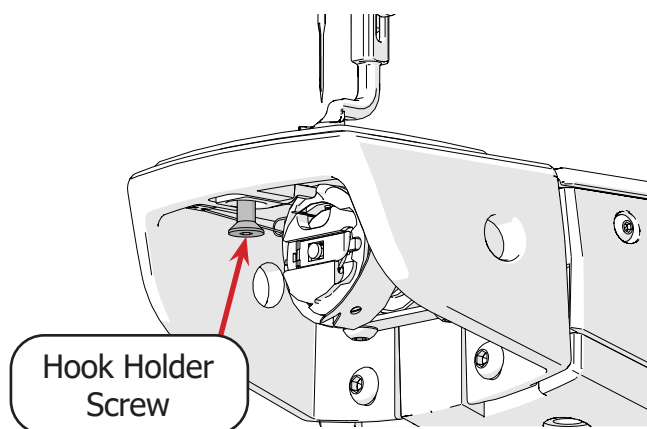

- 3 The **hook holder** will slide free of the machine.

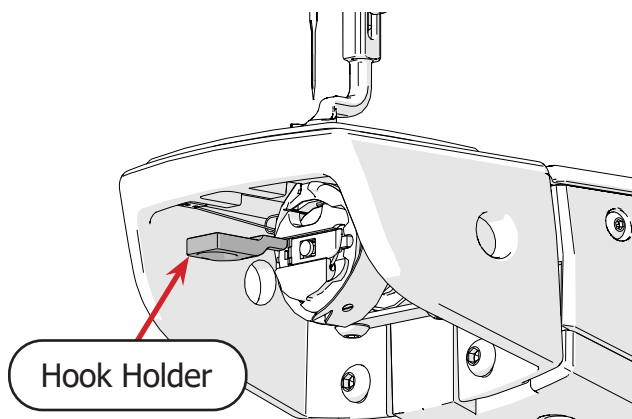

Reinstalling the Hook Holder (continued)

Installation Instructions

- 1 Power off the machine and raise the needle to the highest position using the **hand wheel**.

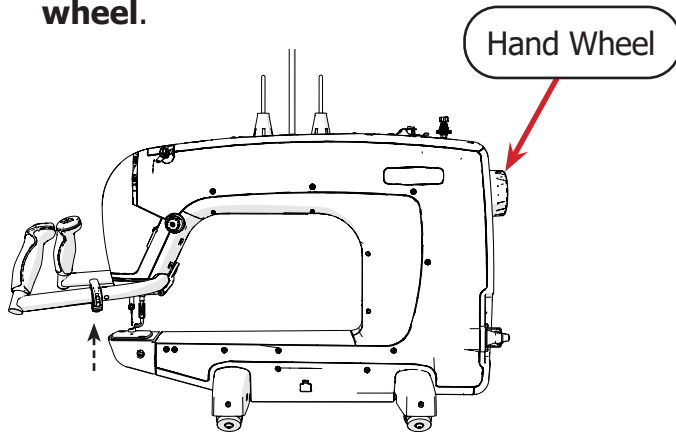

- 2 Remove the needle plate (see page 51).

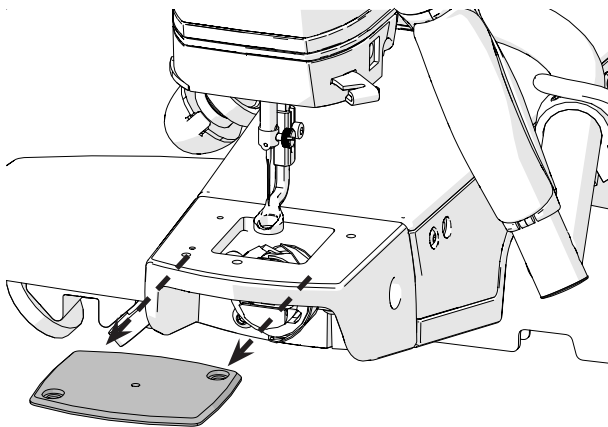

- 3 Remove the bobbin case from the hook assembly (see page 22).

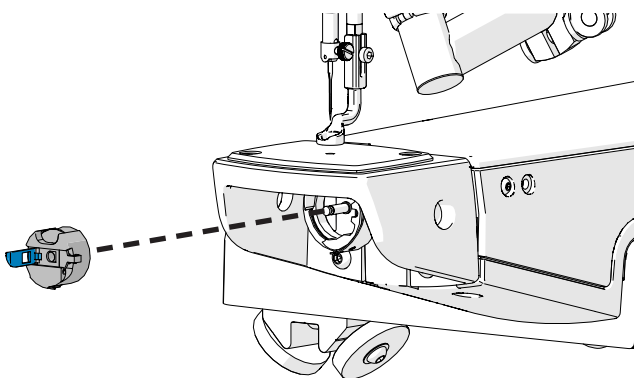

- 4 Turn the inside part of the **hook assembly** (shown in blue) so that the **positioning guide** is at the highest point.

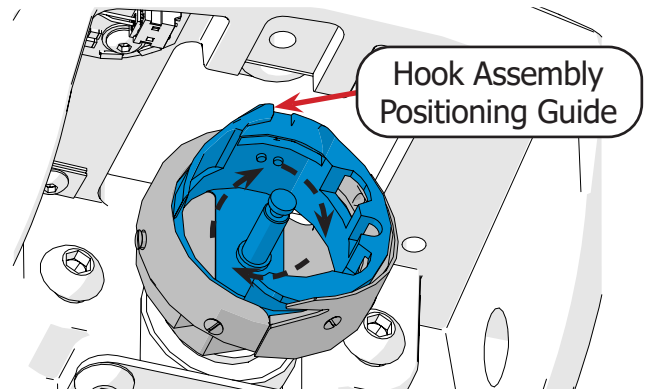

- 5 Slide the **finger** of the **hook holder** into the middle of the **hook assembly's positioning guide** (shown in blue).

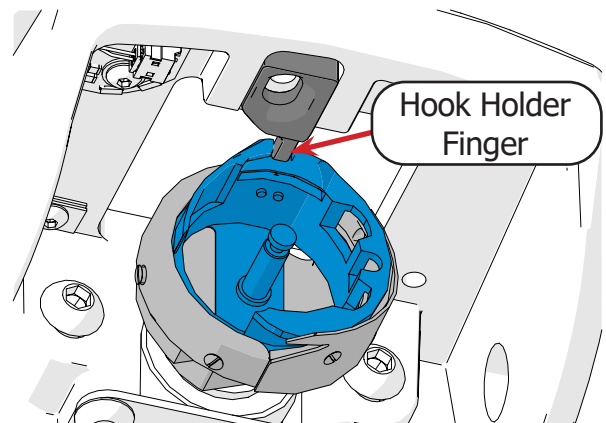

- 6 Attach loosely with the **hook holder screw**. Do not tighten.

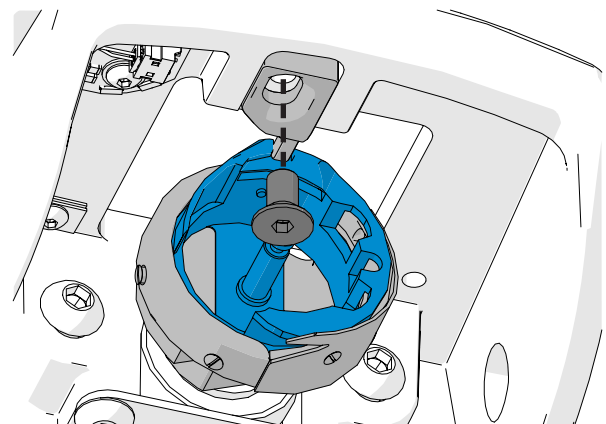

Reinstalling the Hook Holder (continued)

- 7 Align the **hook holder** with the inside edge of the **positioning guide**, as shown below.

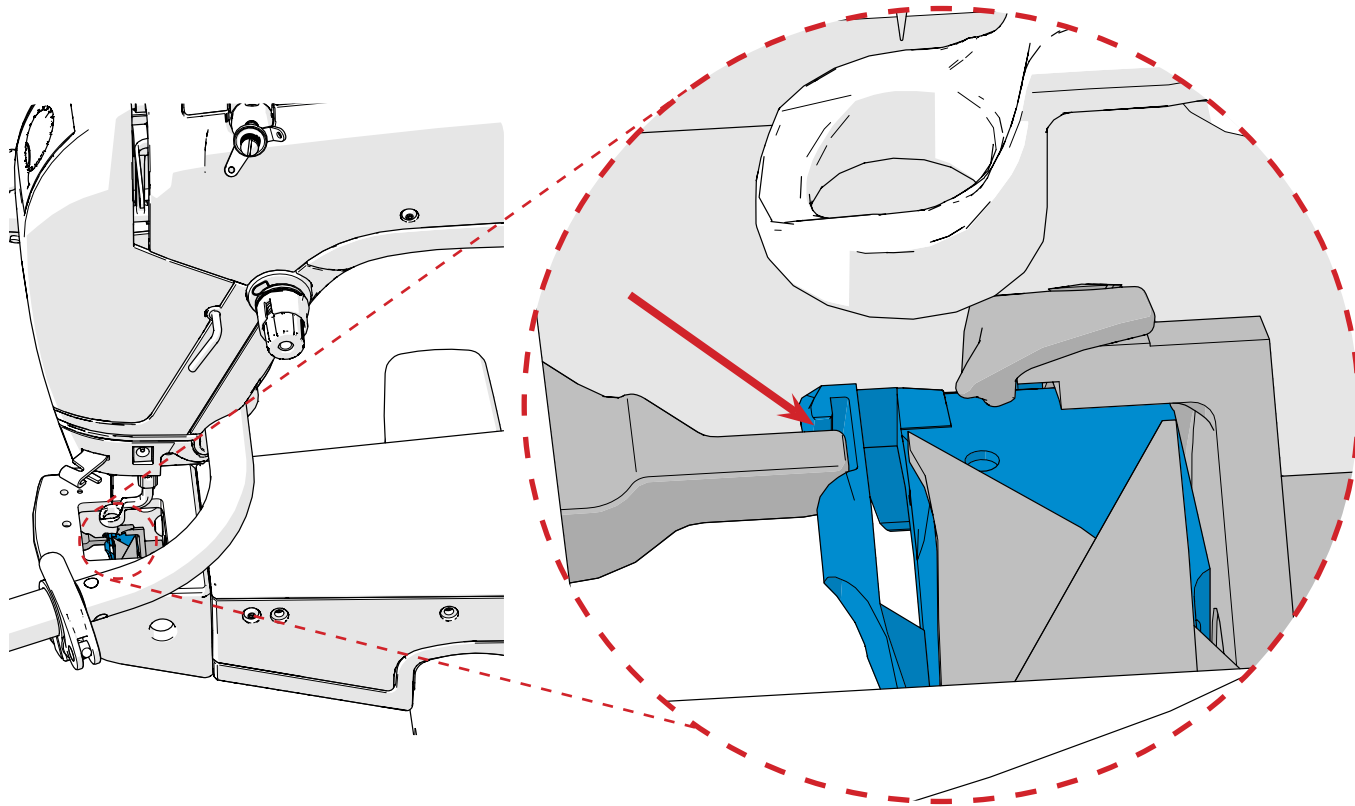

- 8 Tighten the hook holder screw to fasten the hook holder in place. The inside part of the hook assembly should no longer rotate freely by hand.

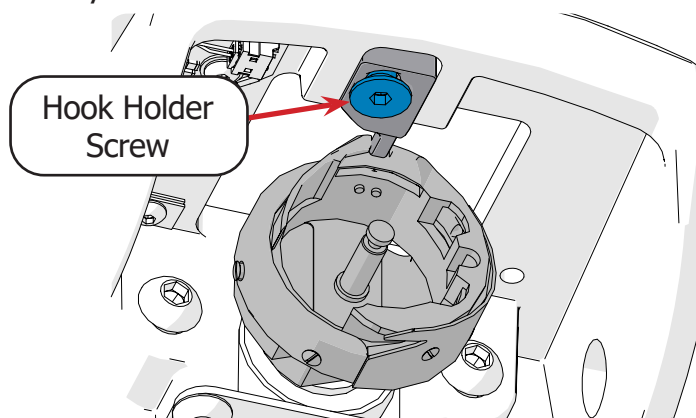

- 9 Reinstall the needle plate by following the steps on page 51.

Adjust the hopping foot height by following the steps on page 48.

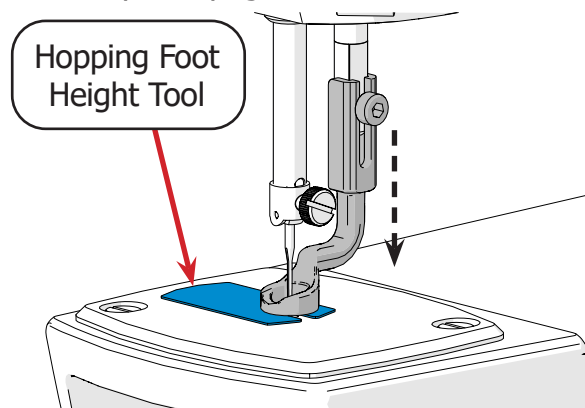

Timing the Machine

Please speak to a Grace Company support technician before attempting these instructions.

Parts & Tools Needed:

Flat-head Screwdriver

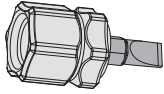

Tools Box

T-handle Allen Wrench 2 mm

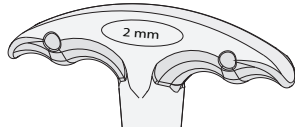

Tools Box

Timing Spacer Tool

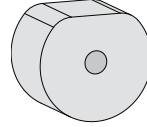

Tools Box

Instructions

Timing your machine aligns the needle and hook assembly so that they are in the correct places during the creation of a stitch. Improper timing can result in damage to the machine and needle, or make sewing impossible. Please consult with a Grace Company support technician before attempting to adjust the timing on your machine.

- 1 Power off the machine and raise the needle to the highest position using the **hand wheel**.

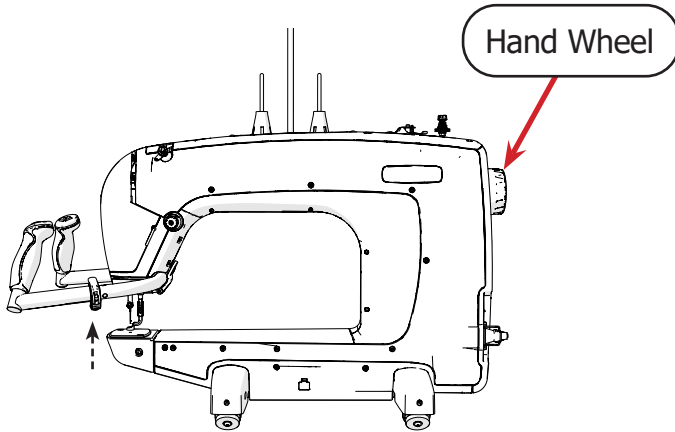

- 2 Remove the needle plate (see page 51).

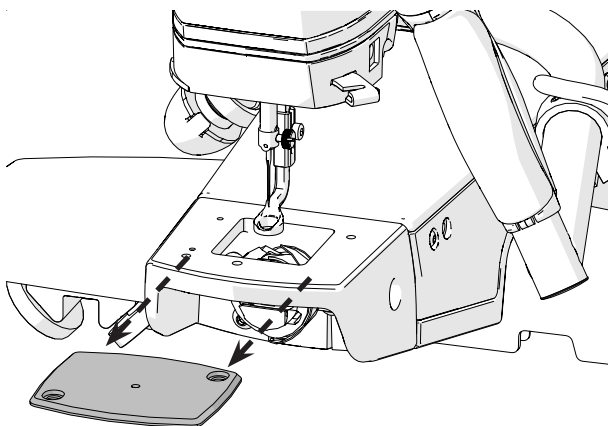

- 3 Remove the bobbin case from the hook assembly (see page 22).

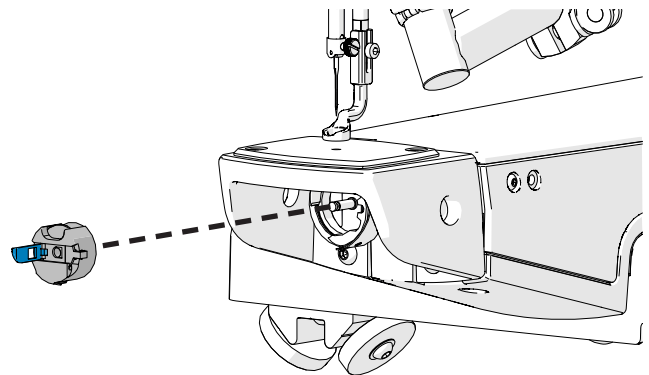

- 4 Look into the machine's **timing cut-out** and turn the hand wheel. The **hook assembly** will rotate.

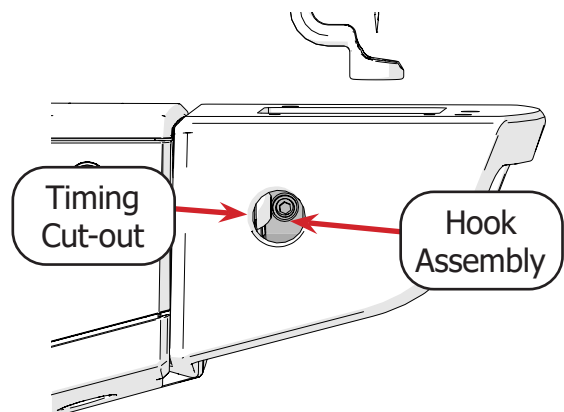

Timing the Machine (continued)

- 5 As each of the **3 set screws** aligns with the cut-out, loosen them with the 2 mm Allen wrench. DO NOT remove these screws.

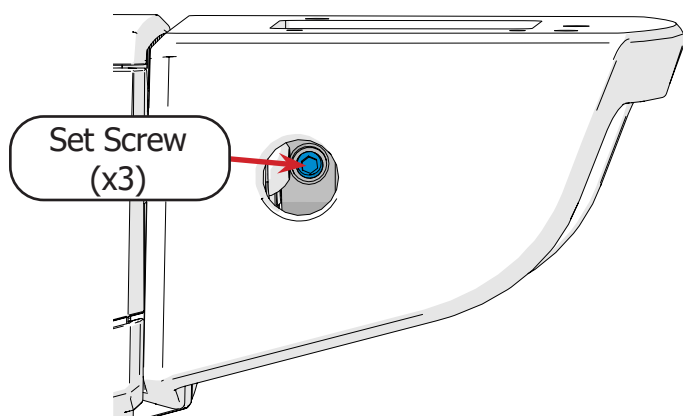

- 6 The **outside** part of the hook assembly (shown in blue) now rotates by hand. Turn the outside part of the hook assembly so that the **hook** is at the top.

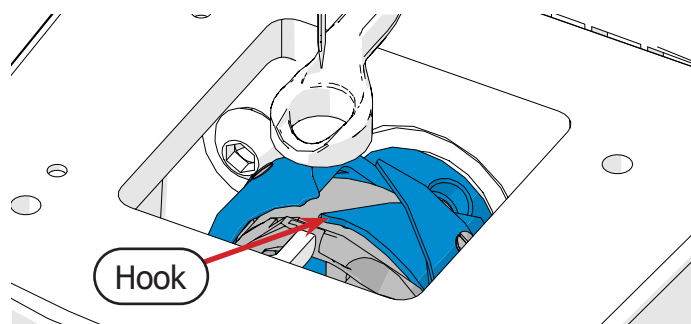

- 7 Carefully rotate the hand wheel to drop the **needle** (shown in gray) all the way to the lowest point. Continue rotating the hand wheel the same direction. The **needle** should begin to raise up.

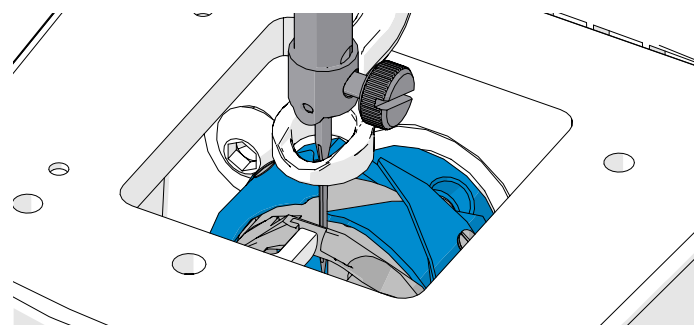

- 8 Stop raising the needle once the eye is about level with the **hook** (shown in blue). Do not continue to raise the needle. If the needle reaches the top of its rotation (over the hopping foot), start over at step 7.

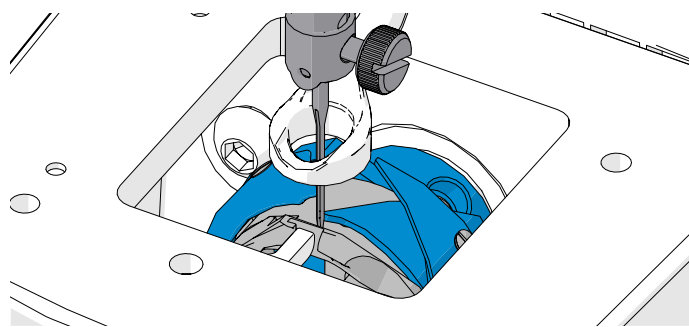

- 9 Slip the **timing spacer tool** (shown in blue) into the hook assembly with the flat side facing up. Then turn the timing tool until the flat side faces down.

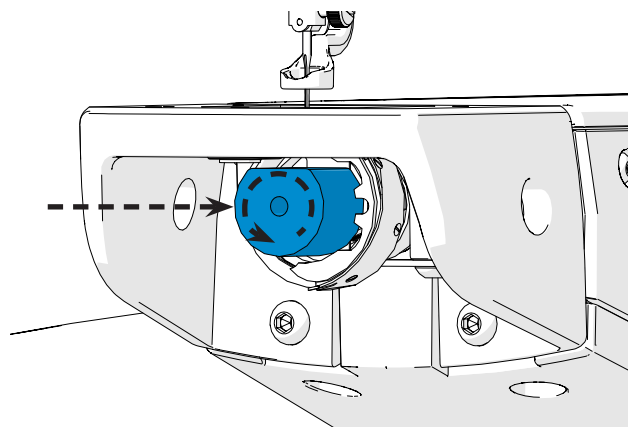

- 10 Turn the hand wheel the opposite direction to bring the **needle** back down until it rests on top of the **timing spacer**. Do not let the **needle** rise to the top before bringing it back down or you will need to repeat steps 7-10.

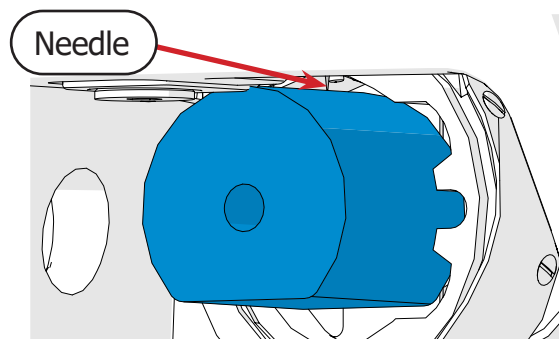

Timing the Machine (continued)

- 11 Position the tip of the **hook** (shown in blue) in the middle of the back of the **needle** (shown in dark gray). This is easier to see from the back of the machine.

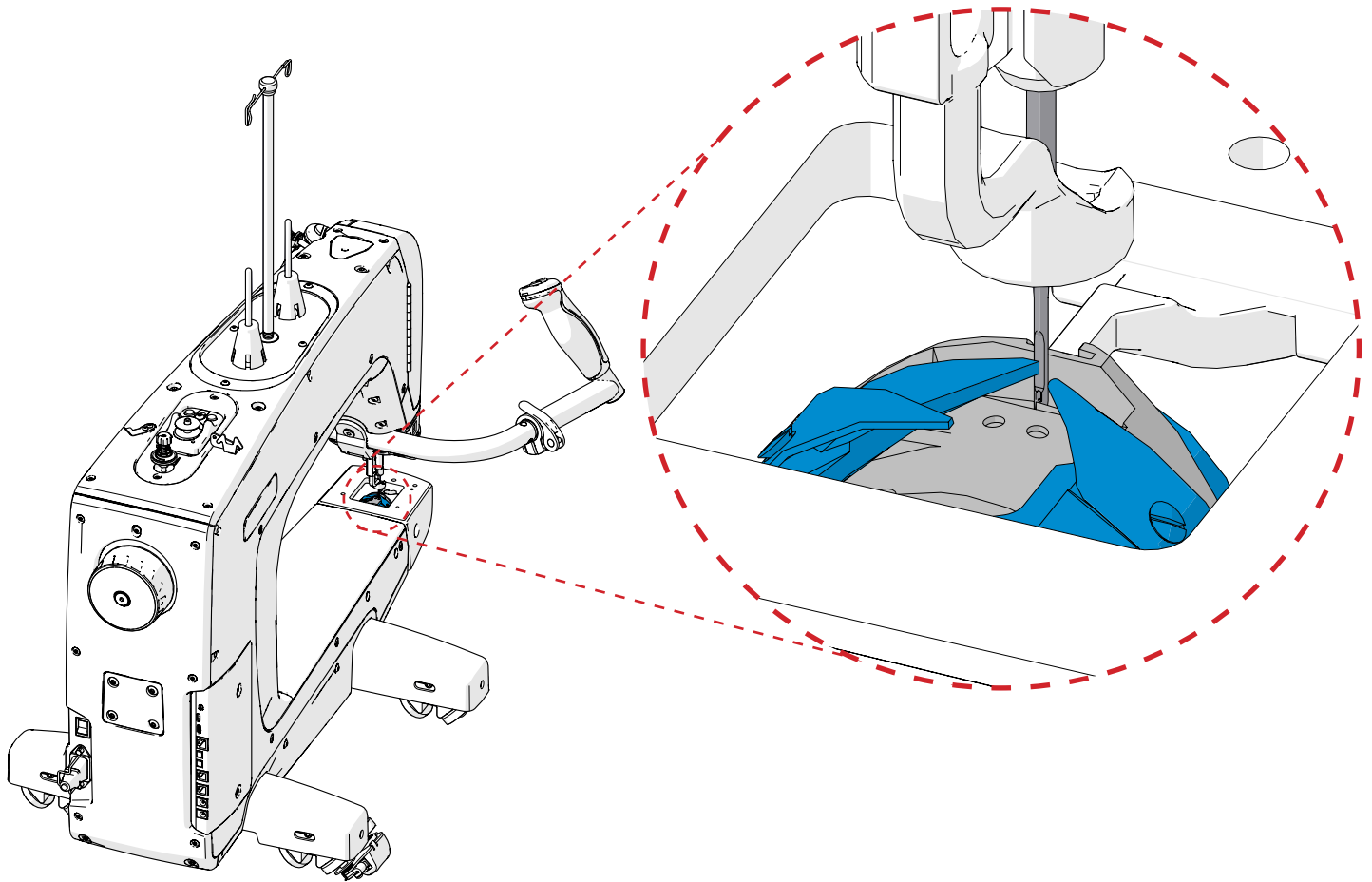

- 12 Pull the hook assembly toward the front of the machine until the hook is as close to the needle as possible without touching
- 13 Use the 2 mm Allen wrench to tighten one of the three **set screws** through the timing cut-out window on the left.

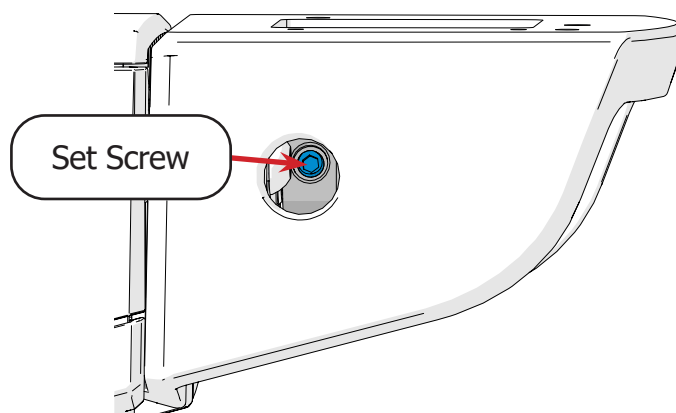

- 14 Turn the timing spacer tool until the flat side is facing up and then remove it from the machine.

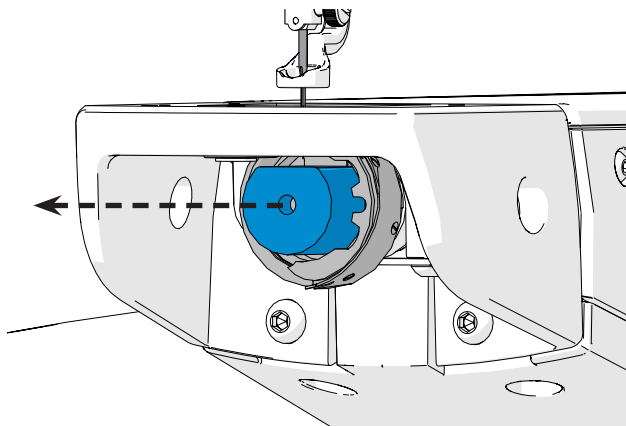

- 15 Turn the hand wheel a full rotation to listen for clicking noises and to ensure the needle does not bend or hit the hook.
- 16 Tighten the two remaining **set screws** through the timing cut-out.

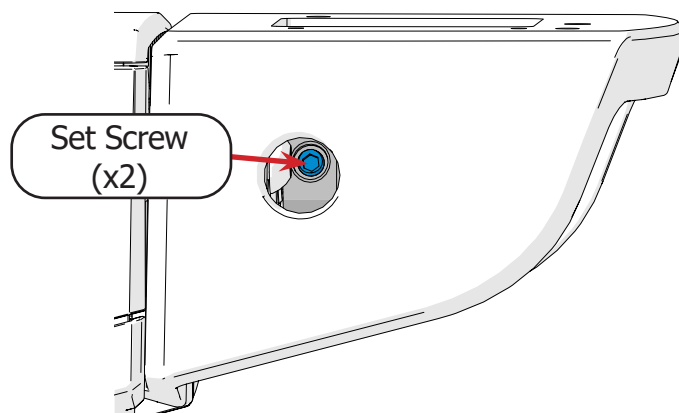

- 17 Replace and align the needle plate (see page 51). Make sure the needle is in the center of the needle plate.
- 18 Replace the bobbin case (see page 22).
- 19 Replace the hopping foot and adjust hopping foot height (see page 48).
- 20 Test the machine and listen for any unusual noises. If there are any skipped stitches, the hook is too far away from the needle. If the thread breaks, the hook is too close to the needle.

Appendix

This section of this manual covers additional information on quilting with your machine.

Choosing Your Needle	page 64
Choosing your Thread	page 66
Choosing Your Fabric and Batting	page 69
Troubleshooting Guide	page 70
Index	page 72

Choosing Your Needle

Using the wrong type of needle, or using a needle that is bent, broken, or blunt, can damage the fabric, the machine, and needle. For best results:

- Use the recommended needle style for your machine (see below).
- Use the needle size appropriate for the weight and type of thread you're using (see below).
- Never use a needle that is dull, bent, burred, or damaged.
- Use multi-directional needles.
- Change your needle after 8 hours of use and at the beginning of each project.

Needle Style

The following are the recommended needle styles for your machine:

- DPX5 MR
- 134 MR
- 1955 MR

Needle Sizes

Choose the size of your needle based upon the thread you're using. Thicker thread requires a thicker needle. Remember, the thicker the thread, the lower the thread weight (wt.) number.

Needle Size	Thread Size and Type
14 / 90	<ul style="list-style-type: none"> • mono-filament • 100 wt. silk • 60 wt. polyester
16 / 100	<ul style="list-style-type: none"> • mono-filament • 60 wt. polyester or cotton • 50 wt. cotton
18 / 110	<ul style="list-style-type: none"> • 50 wt. polyester • 40 wt. cottons and polyester • 30 wt. cotton and polyester
20 / 125	<ul style="list-style-type: none"> • 30 wt. or heavier of any thread

Choosing Your Needle (continued)

Needle Diagram

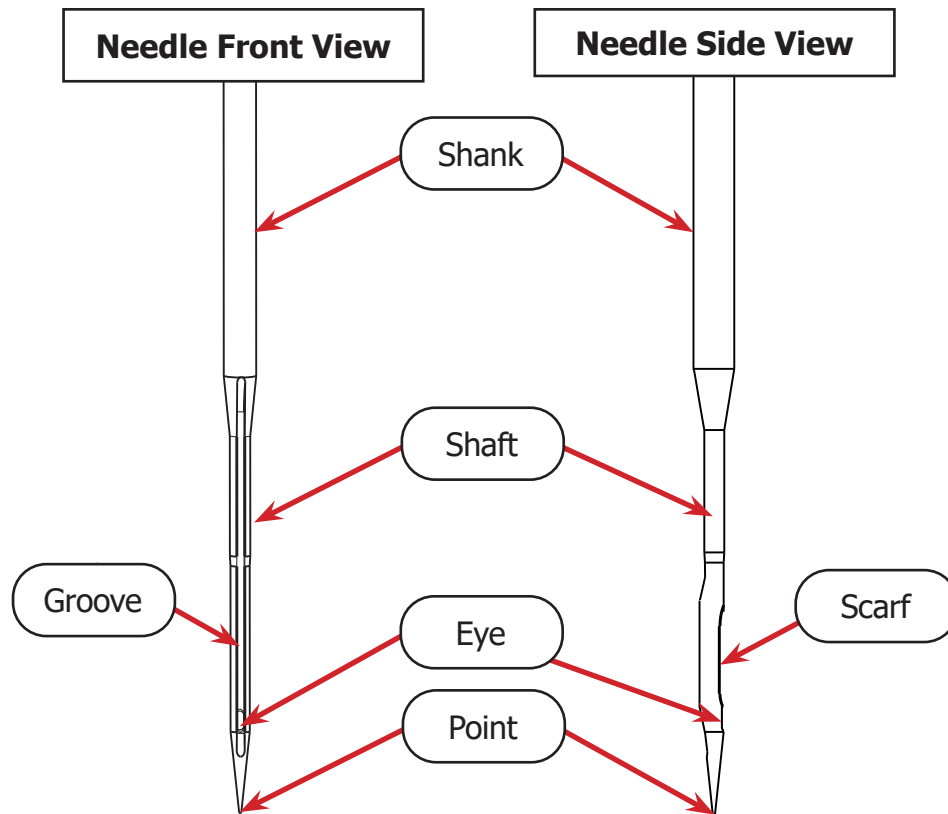

- **Shank:** Where the needle bar grasps the needle.
- **Shaft:** The long, narrow part of the needle. Needle size is based upon the diameter of the needle shaft.
- **Groove:** Reaching from the top to the bottom of the needle shaft, the groove allows thread to pass through the fabric more easily and without getting damaged.
- **Eye:** Hole near needle point where the needle is threaded.
- **Scarf:** A cut-away on the back of the needle that allows the needle to fit smoothly within the hook assembly when quilting.
- **Point:** The sharp end of the needle. Choose the type of needle point to fit your project, and always replace your needle once the point is dull.

Choosing Your Thread

Choosing the best thread for your project is just as important as choosing the correct needle. Good thread is strong and can pass the “Yank Test” (see “Task 8 - Threading the Machine” on page 24). It holds its color well over time (colorfastness), and uses long fibers (extra-long staple) that resist pilling or creating lint.

Thread type and size determines not only which needle size to choose and what the thread tension must be set to on your machine, but also how visible the thread is on the project.

For best results:

- Use a cone-style thread unless you have the thread spool accessory for your machine.
- Test the strength of thread before use with the “yank test” (see “Task 8 - Threading the Machine” on page 24).
- Practice using new thread on spare quilting materials to find the ideal thread tension. Write this information down and store it with your thread for later reference.
- Keep thread out of sunlight to prevent fading, and do not store near extreme temperatures.
- Select thread that is ideal for the fabric you’re using (see the chart below).
- Avoid using different thread type for the top thread than you’re using for the bottom thread.

Thread Type Guide

Threads can be multiple strands, called plies, spun together, or it can be a single ply. The fibers that make up the ply can come from many sources, but the most common threads used in quilting are made from cotton, polyester, and silk. The unique properties of each material make some threads better suited for use on some fabrics than others.

Thread Type	Ideal Fabric
Cotton	<ul style="list-style-type: none"> • Cotton • Linen • Rayon
Polyester	<ul style="list-style-type: none"> • Knit or Stretch • Woven synthetic
Silk	<ul style="list-style-type: none"> • Silk • Wool • Basting thread for all fabrics

Choosing Your Thread (continued)

Thread Size

The thickness of the thread is called the weight (wt.). This number is usually stamped on the edge of the top or bottom of the thread cone. Notice that as the thread becomes heavier and thicker, the weight decreases:

- 60 weight: Very thin, fine thread that will blend in to the fabric.
- 40 weight: Thicker thread that will show up on the fabric.

Note: choose matching weight and thread type when picking top and bottom (bobbin) threads.

Tip: Not all manufacturers will have the same sizing method for their thread. Threads can be measured by weight, tex, denier, or scaling that is unique to its brand. Take the time to understand how the sizing works for a brand you're considering, and keep a few common sewing rules in mind:

- The thicker the thread, the larger the needle required. A needle that is too thin can shred thread.
- The thinner the thread, the smaller the needle should be. A needle that is too large will cause uneven stitching and can leave holes in the fabric.

Thread Processing

Sometimes thread is processed to change its properties. The chart below lists the processes common to cotton and polyester. No extra processing or treatments are typical for silk.

Thread Type	Processing
Cotton	<ul style="list-style-type: none"> • Mercerized: Treated to improve strength and colorfastness. • Glazed: Waxed or coated to give a polished appearance. The coating may rub off and build up in machine. • Gassed: Exposed briefly to a gas flame to burn away fuzz and lint, giving a smooth appearance.
Polyester	<ul style="list-style-type: none"> • Lubricated: Treated with lubricant to reduce friction. Avoid thread that is oily to the touch. • Bonded: Treated with resin to increase strength. This is typically used for heavy-duty applications, such as upholstery.

Our Recommended Thread

Finesse thread is specially-designed for quilting by the Grace Company. It can be used with domestic (sewing) and quilting machines, and comes in 60 colors.

- 100% Polyester, 3-ply thread
- 1,500 yards mini-cone
- 50 wt.
- 110/18 or 100/16 quilting machine needle
- Topstitch 90/14 sewing machine needle



Choosing Your Fabric and Batting

Fabric

Some fabrics are not recommended for use with the quilting machine. Thick fabrics, such as denim or leather, have a lot of resistance that can bend or snap a needle, and misalign or break internal machinery. When quilting, avoid any fabrics that are difficult to pierce, and take care that the fabric layers of the quilt are well balanced .

Batting

To choose the best batting for your project, consider the look and feel of the quilt that you're going for. Batting thickness is measured by its loft. A low loft batting is thinner and lighter, ideal for a quilt with a flatter appearance. High loft batting should be used if a fluffy, full quilt is the goal. Typically, wool batting is the thickest batting while bamboo is the lightest. Wool provides the most warmth, followed by polyester, and then cotton.

Troubleshooting Guide

Issue	Cause(s)	Solution
Machine won't turn on.	Loose cables	Check that all cables are securely plugged in (page 17).
	Machine is not turned on	Check power button is pressed down on right side (page 17).
	If problem persists, please contact a Grace Company support technician. Call (800) 264-0644 .	
Stitches are skipped.	Damaged needle	Check needle (page 46).
	Machine improperly threaded	Check that all tensioners and guides were threaded correctly (page 24).
	Bobbin wound or threaded incorrectly	Check that the bobbin was inserted the correct direction in the case (page 22).
	Incorrect thread tension	Adjust top thread tension (page 33). Adjust bottom thread tension (page 19).
	Hopping foot incorrect distance from needle plate	Check hopping foot height distance with height tool (page 48).
	If problem persists, please contact a Grace Company support technician. Call (800) 264-0644 .	
Thread is breaking.	Damaged needle	Check needle (page 46).
	Incorrect thread tension	Adjust top thread tension (page 33). Adjust bottom thread tension (page 19).
	Machine improperly threaded	Check guides and tensioners for accidental double-wrapping (page 24).
	Stitching in place too long	Keep machine moving to avoid stitch build-up in one place.

Troubleshooting Guide (continued)

Issue	Cause(s)	Solution
Thread is breaking.	Bobbin inserted incorrectly	Check bobbin is the correct direction in the case and inserted firmly (clicked) into the machine (page 22).
	Debris on tension discs	Clean the machine (page 42).
	Burred bobbin	Check bobbin for sharp edges. Contact your dealer to replace if needed.
	Needle plate is rubbing needle	Check that needle plate is centered and does not hit needle (page 51).
	If problem persists, please contact a Grace Company support technician. Call (800) 264-0644 .	
Machine is running loud.	Machine and/or hook assembly needs oiling	Oil the machine and hook assembly (page 42).
	Bobbin winder is on	Press the "off" button on the bobbin winder (page 19).
	If problem persists, please contact a Grace Company support technician. Call (800) 264-0644 .	
Thread is bunching up in hook assembly (bobbin case area).	Bobbin wound or threaded incorrectly	Check that the bobbin was threaded correctly and inserted the correct direction in the case (page 19).
	Machine improperly threaded	Check that all tensioners and guides were threaded (page 24).
	Incorrect thread tension	Adjust top thread tension (page 33). Adjust bottom thread tension (page 19).
	Bobbin case has damaged or missing spring	Check inside bobbin case to see spring. Contact your dealer to replace if needed.
	If problem persists, please contact a Grace Company support technician. Call (800) 264-0644 .	

Index

Symbols

2.5 mm T-handle Allen wrench	16
2 mm T-handle Allen wrench	59
3 mm T-handle Allen wrench	21, 48, 56
4 mm T-handle Allen wrench	7, 13

A

animated instructions	3
anti-backlash spring	54

B

batting	69
bobbin	19, 22
bobbin case	22
bobbin fill adjustment	21
bobbin spring	54
bobbin tension	23
bottle	42
bottom thread tension	23
button labels	32

C

cleaning	42
controls	32

D

decrease speed	32
display	32

E

electrical	iv, 17
encoder port	vii

F

fabric	69
features	iv
Finesse thread	68
flat-head screwdriver	17, 51, 54, 56, 59

G

getting started	36
grounding instructions	ii
guide loops	20, 26

H

handlebar controls	32
handlebars	32
hand wheel	v, vi
hook assembly	56, 59
hopping foot height tool	48

I

included parts and tools	x
increase speed	32

L

lamp	vi
large thread tensioner	33
layout	v
lint brush	42

M

machine dimensions	iv
machine layout	v
machine specifications	iv
maintaining the machine	40

N

needle diagram	65
needle groove	65
needle magnet	46
needle scarf	65
needle size	64
needle stop	32

O

oil bottle	41, 42
------------------	--------

P

parts	x
parts of machine	v
power cable	17
power cable retainer	17
power port	vii, 17
power switch	vii, 17
processed threads	67
pull up bobbin thread	36

Q

Q-display	32
QuiltMotion tablet port	vii

Index (continued)**S**

safety instructions	i
SBHCS Screw M4 x 12 mm	16
SBHCS Screw M4 x 20 mm	16
SBHCS Screw M6 x 35 mm	7
screwdriver	17, 51, 54, 56, 59
Shoulder Bolt M6	7
specifications	iv

T

thread	19
thread cutter	20
thread cutter (top thread)	28
thread size	67
thread stand	20, 26
thread strength	24
thread tension	23
timing spacer	59
troubleshooting guide	70

U

USB connector port	vii
--------------------------	-----

V

video instructions	3
--------------------------	---

W

wheel assemblies	7
wheels	7
winding a bobbin	19

Y

yank test	24
-----------------	----

Information on the disposal for Waste Electrical & Electronic Equipment (WEEE): This symbol on the products and accompanying documents means that used electrical and electronic products should not be mixed with general household waste. For proper disposal for treatment, recovery and recycling, please take these products to designated collection points where they will be accepted on a free-of-charge basis. In some countries you may be able to return your products to your local retailer upon the purchase of a new product. Disposing of this product correctly will help you save valuable resources and prevent any possible effects on human health and the environment, which could otherwise arise from inappropriate waste handling. Please contact your local authority for further details of your nearest collection point for WEEE.



The Grace Company
Phone: 1-800-264-0644
www.graceframe.com

